

TECNOLOGIA DE CONTROLE NUMÉRICO

OPERAÇÃO E
CARACTERÍSTICAS DE
UM EQUIPAMENTO CNC:
EIXOS EM MÁQUINAS
CNC

Eixos de Máquinas CNC

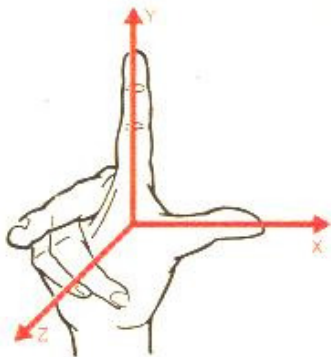
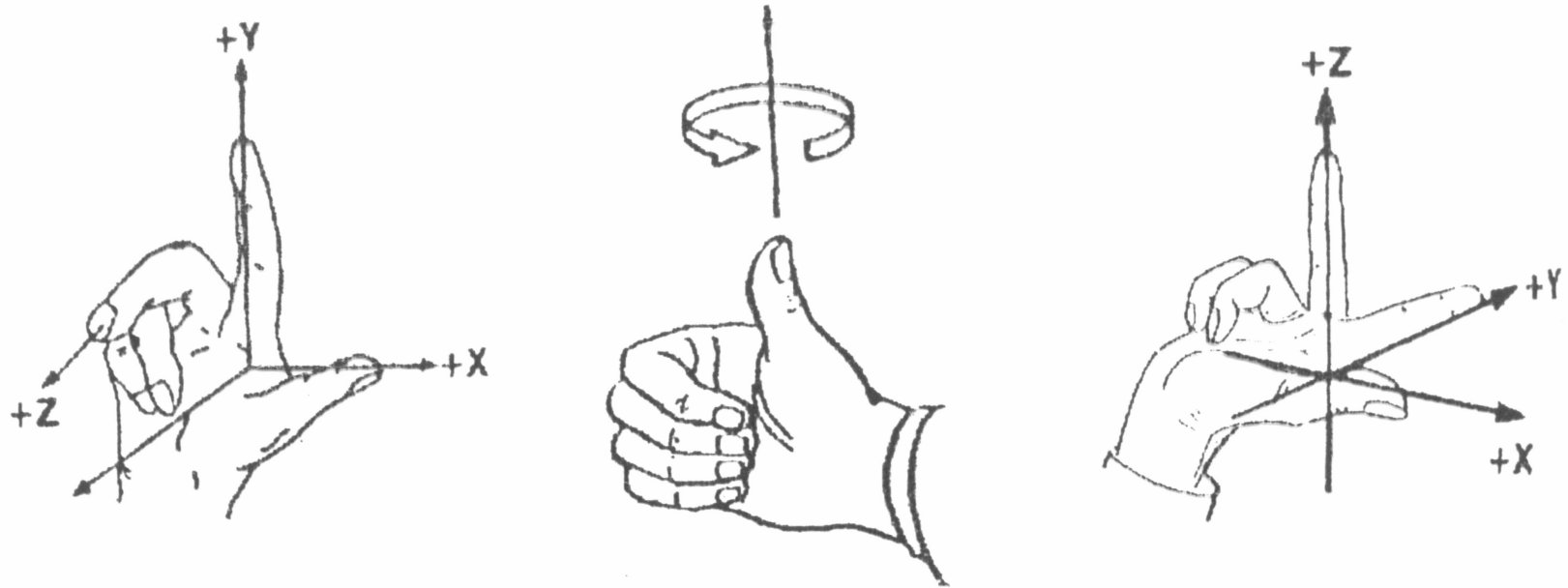

Eixos coordenados: regra da mão direita



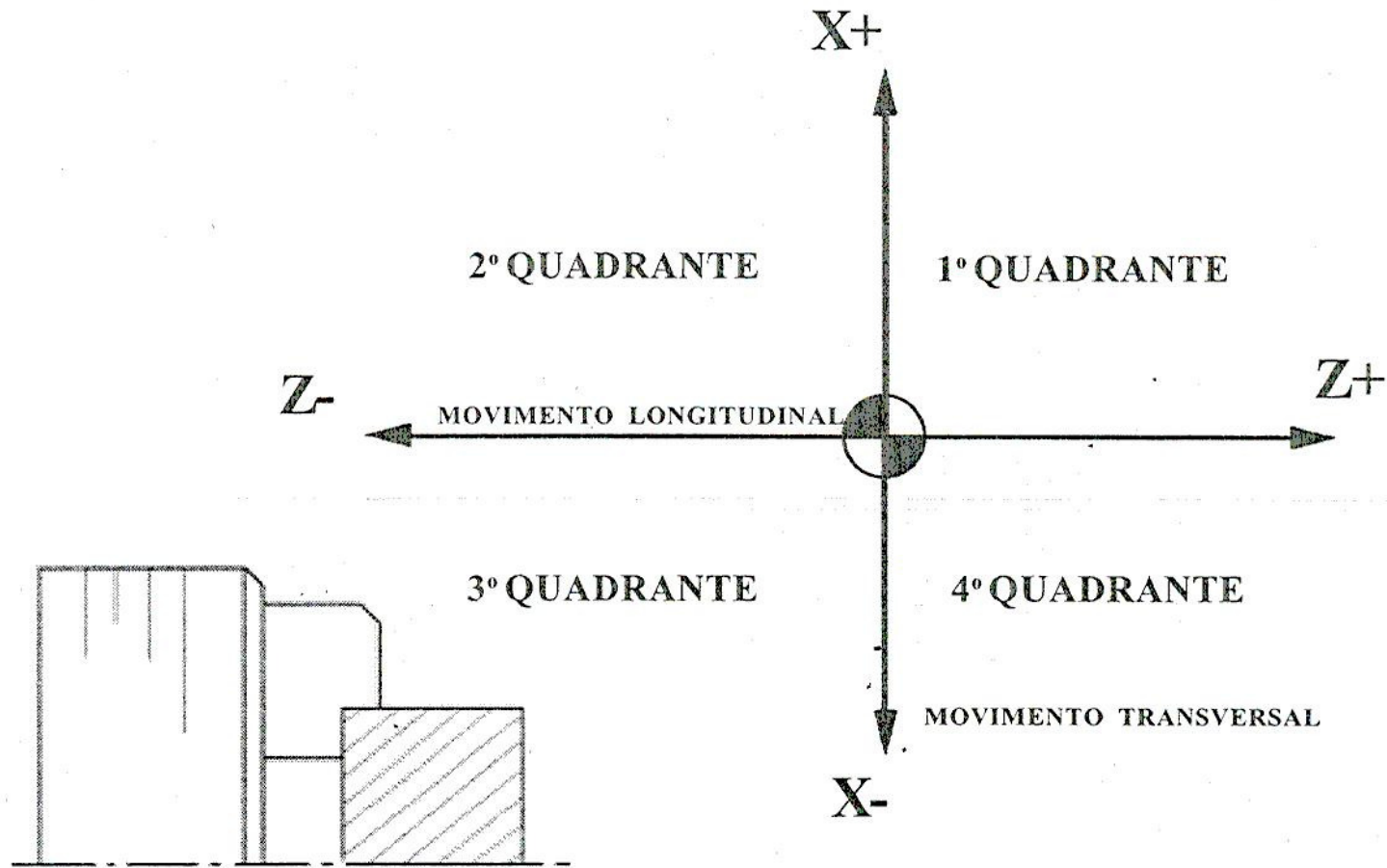

Eixos de um Torno CNC

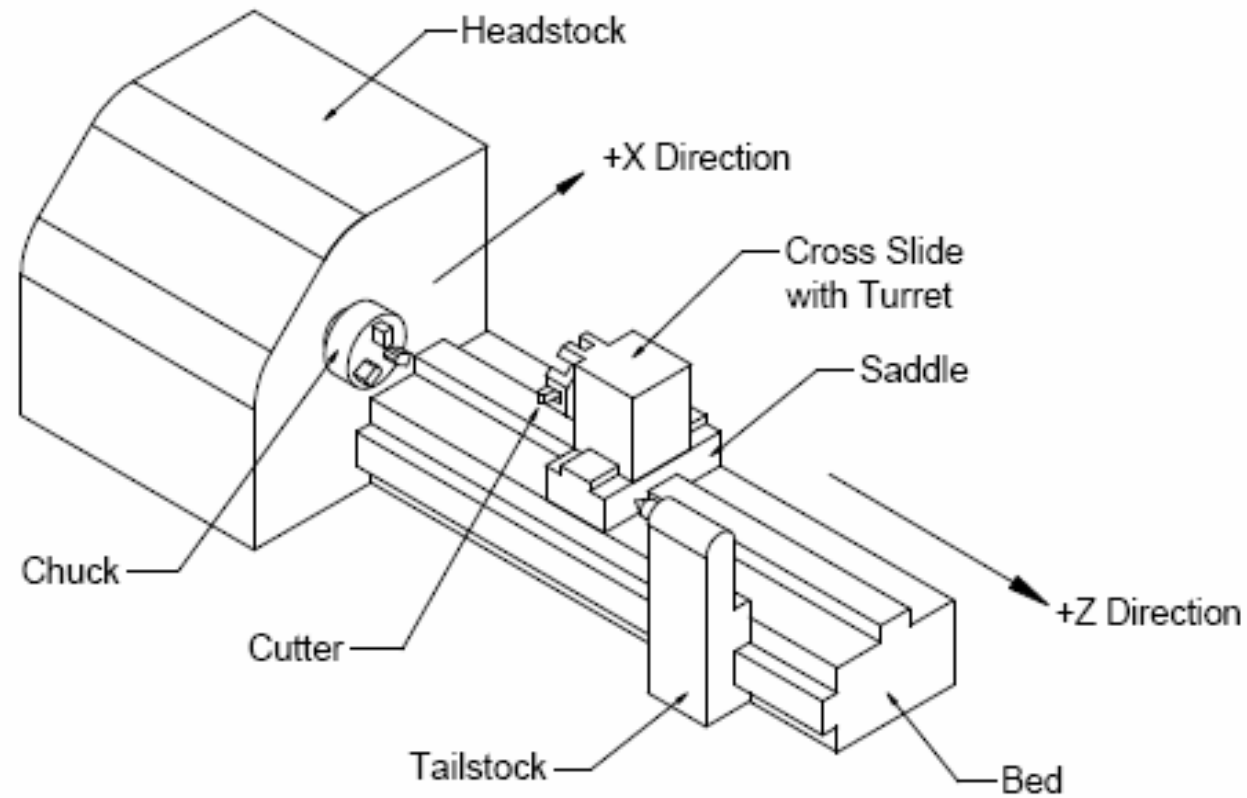

Eixos de um Torno CNC



Outro Torno CNC

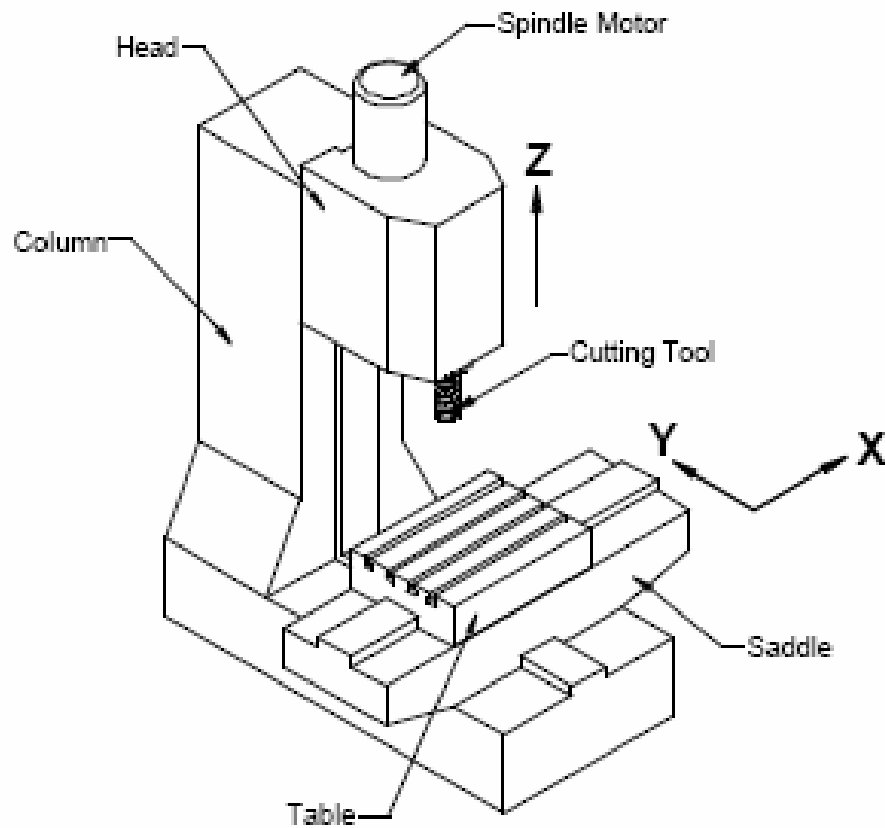

Eixos de um Centro de Usinagem Vertical



**Eixos de um
Centro de
Usinagem
Vertical**

Axis Directions

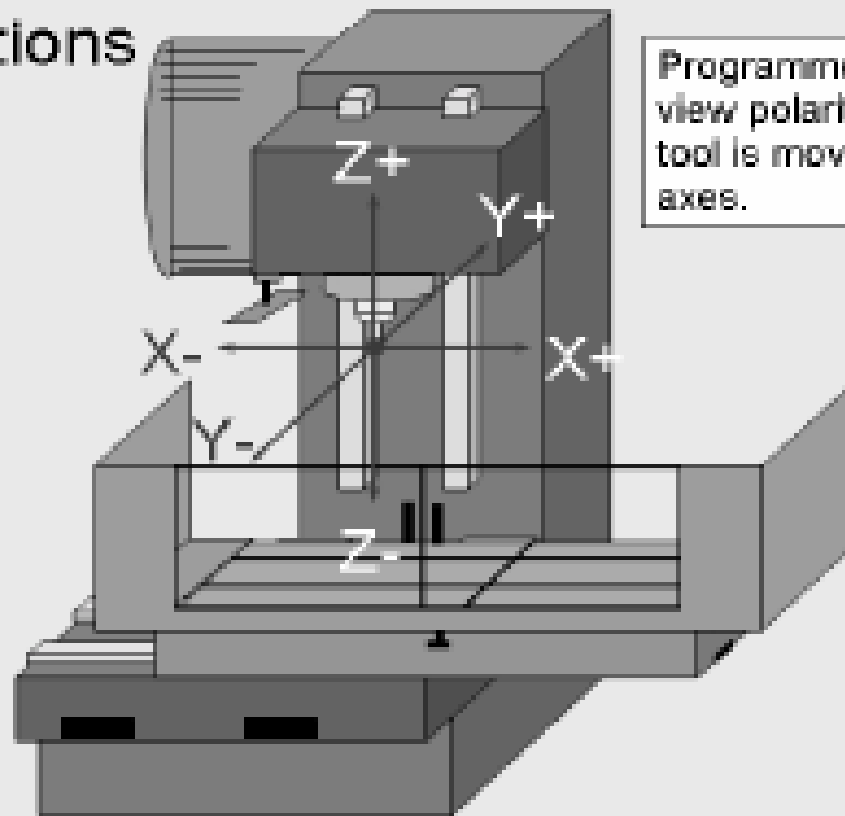

Programmers should view polarity as if the tool is moving in all axes.

Eixos de um Centro de Usinagem Vertical

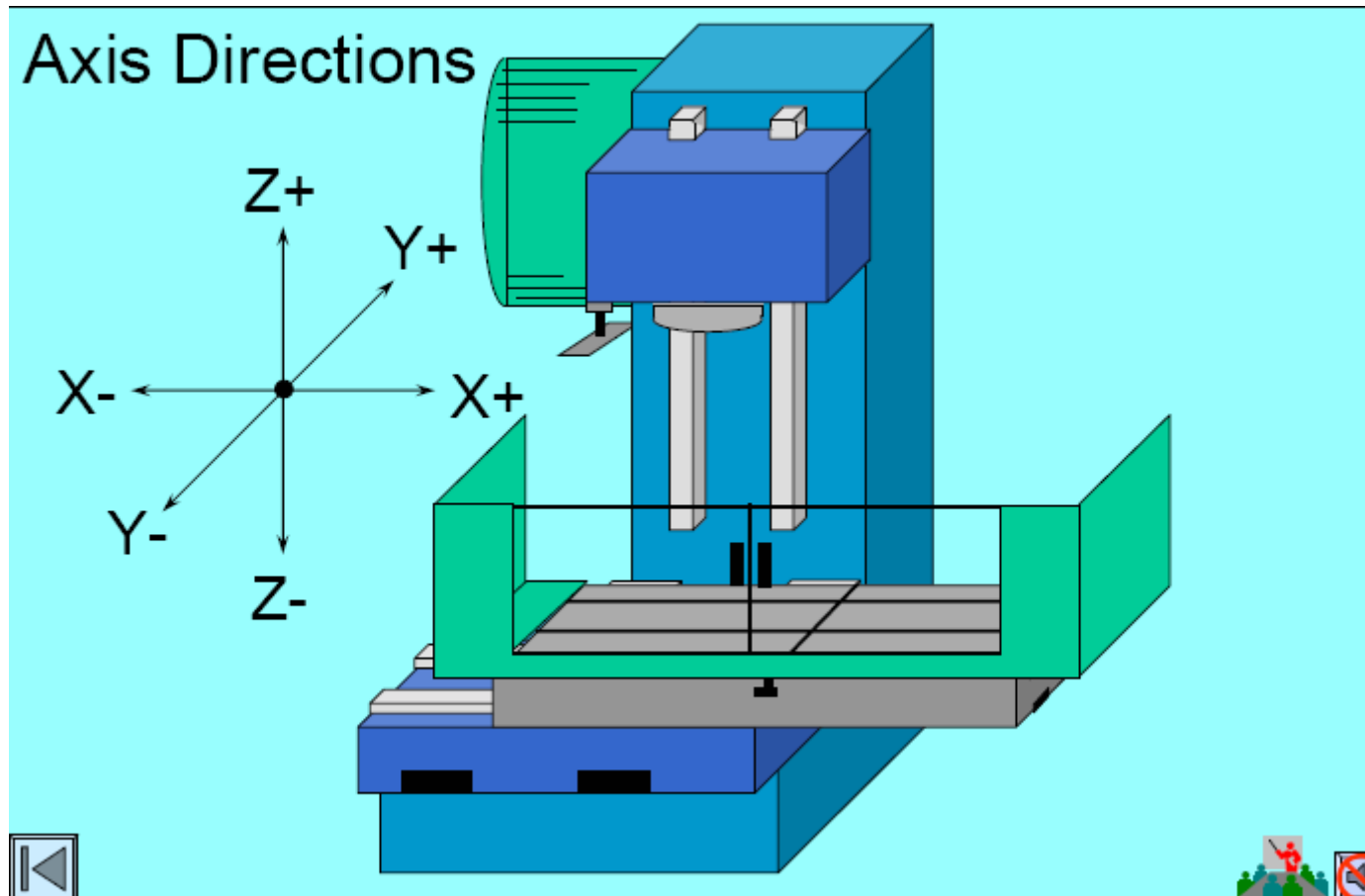

**Eixos de um Centro
de Usinagem Vertical**

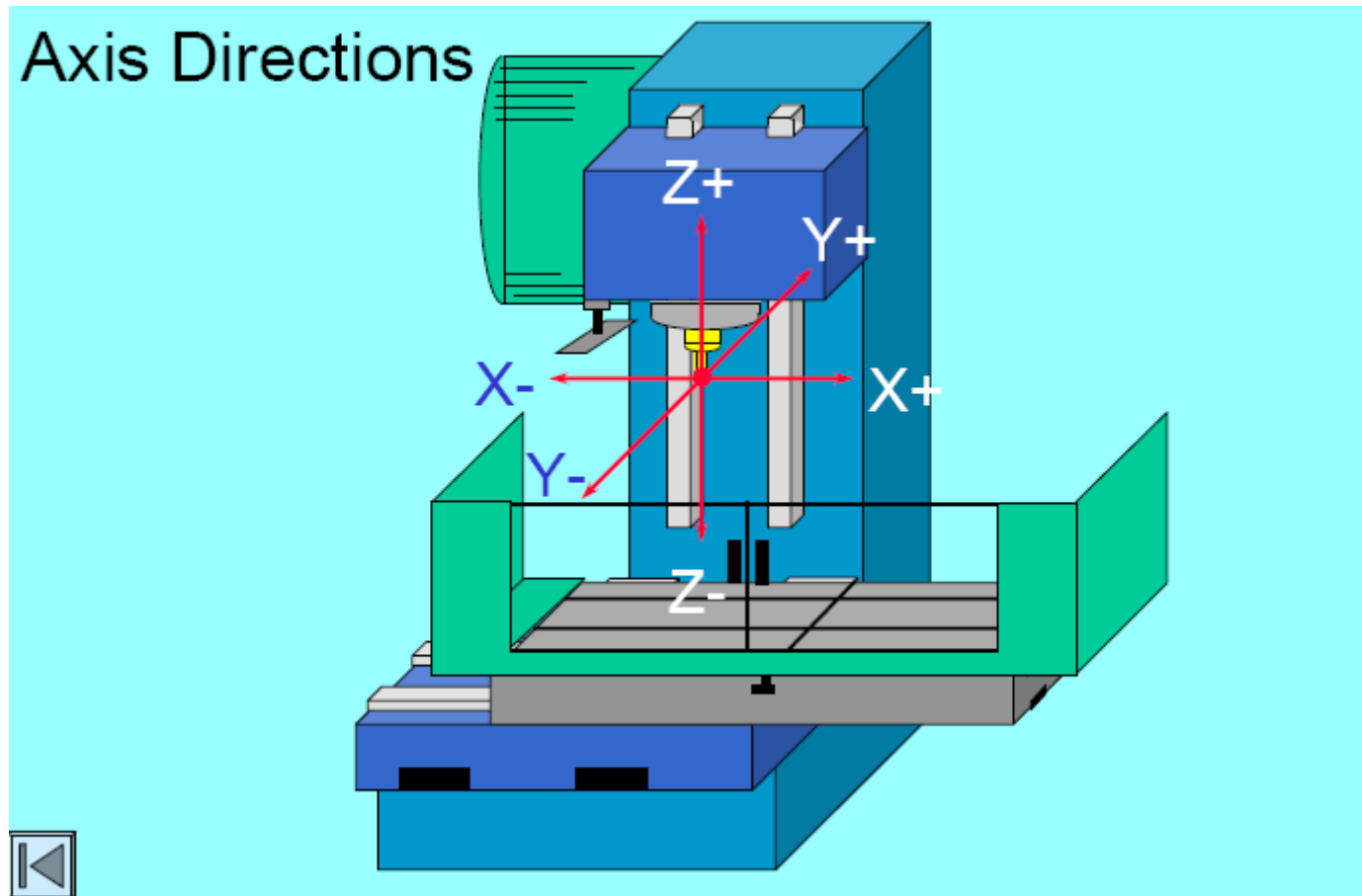

**Eixos de um Centro
de Usinagem Vertical**

Furadeiras

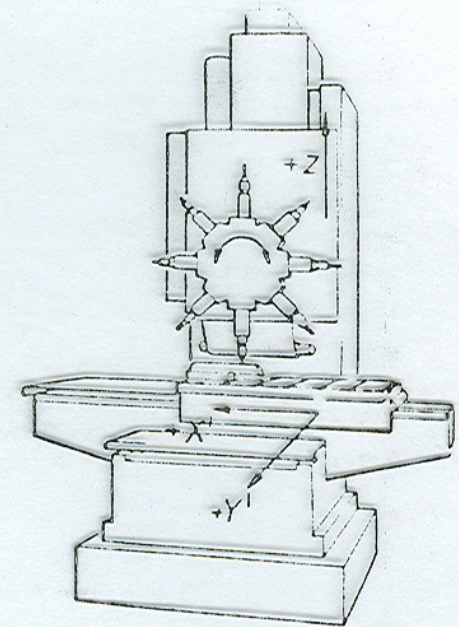
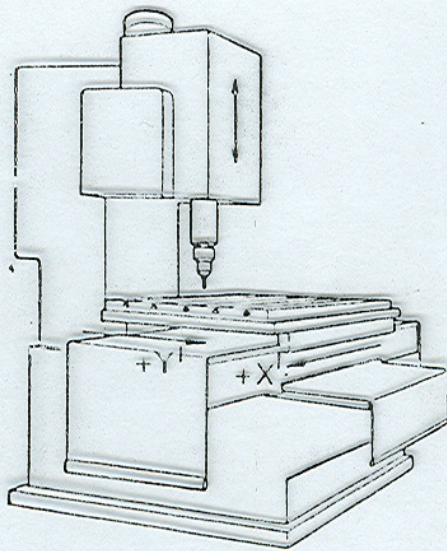

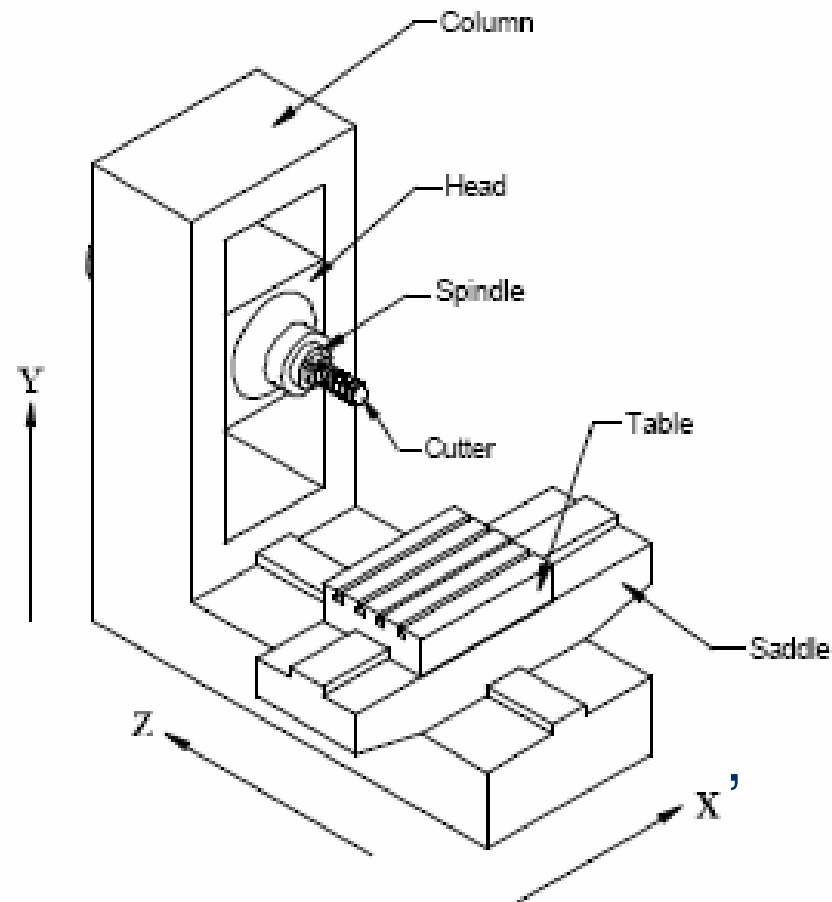

Eixos de um Centro de Usinagem Horizontal

Horizontal Machining Center

This machine is called a horizontal machining center because the spindle is oriented in a horizontal fashion.

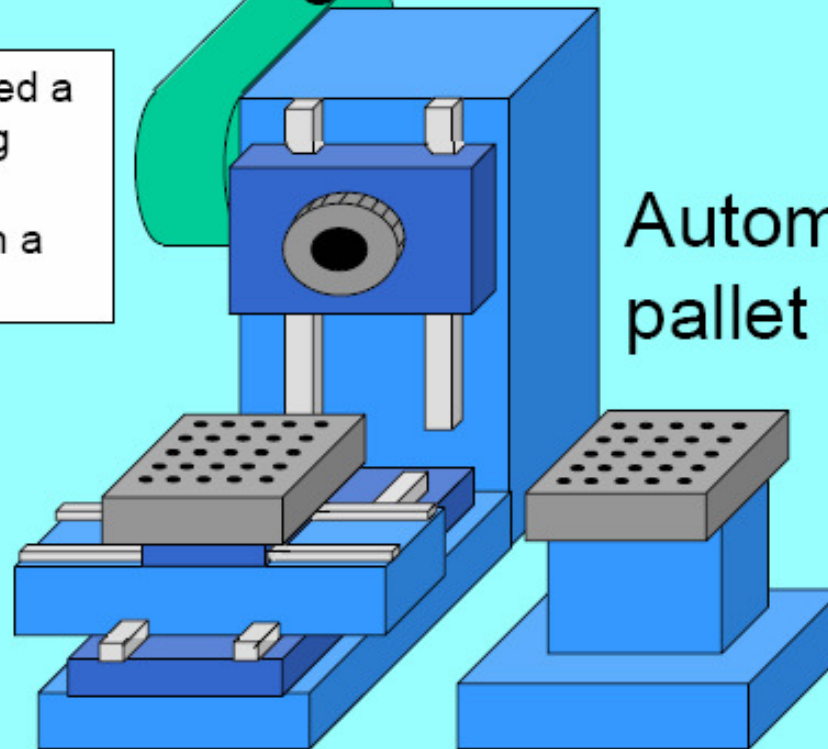

Automatic
pallet changer



Horizontal Style

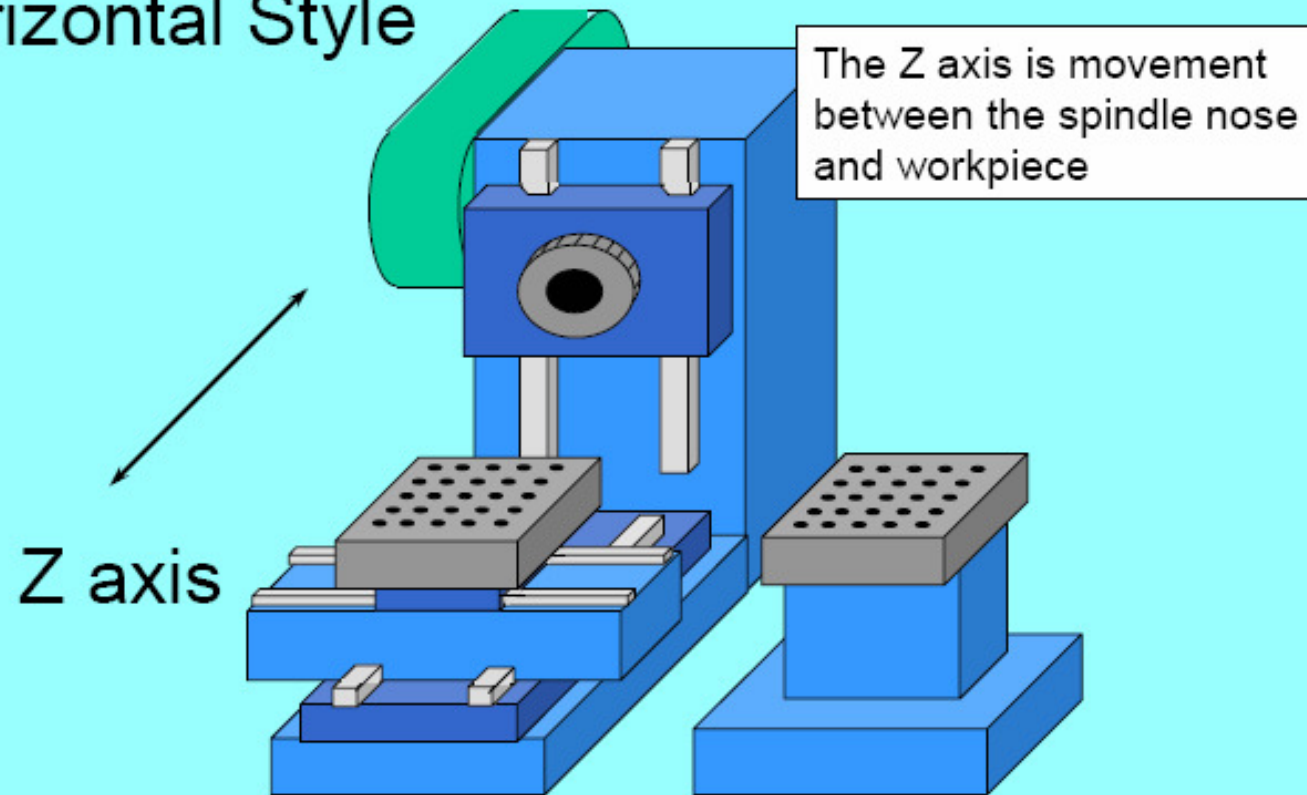

Horizontal Style

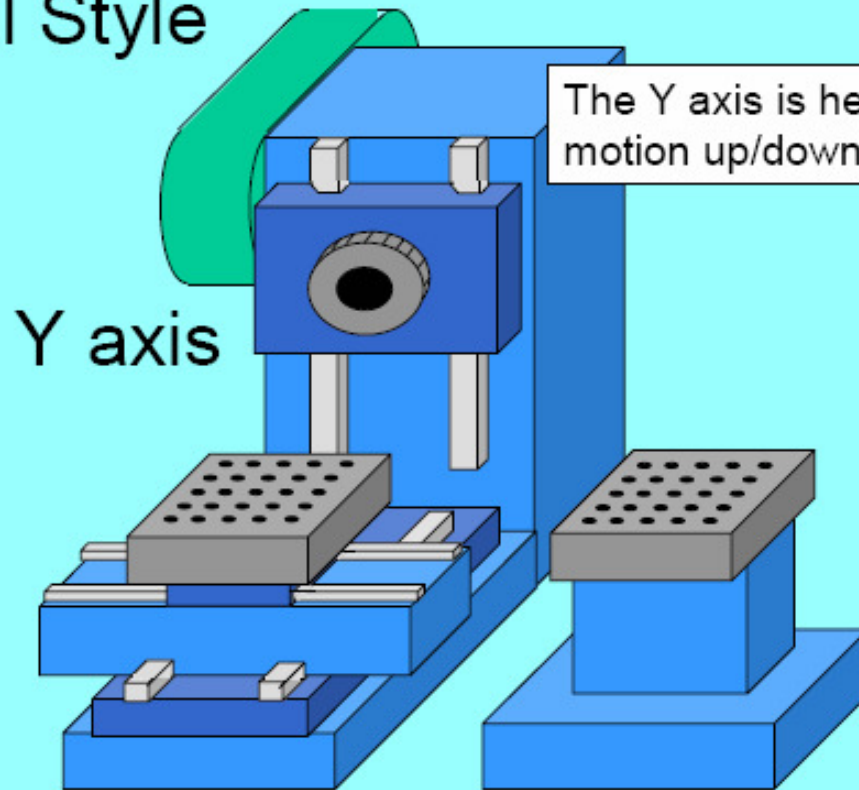

Horizontal Style

Here are the axes for a horizontal machining center

X axis

A 3D schematic diagram of a horizontal machining center. The machine is primarily blue. It features a vertical column on the right side. A horizontal spindle assembly is mounted on the column, with a green curved arrow indicating its rotation. Below the spindle is a table with two T-slots, each containing a grey workpiece with a grid of holes. A horizontal double-headed arrow labeled 'X axis' is positioned to the left of the table, indicating the direction of table travel. The entire machine is supported by a base.

Horizontal Style

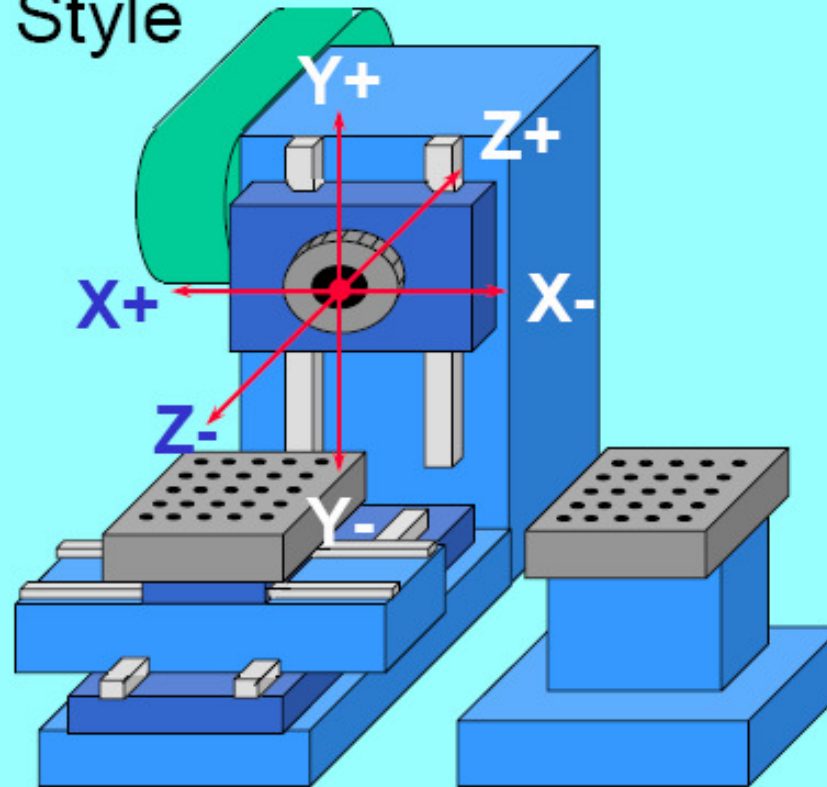

Centro de Usinagem de 3 Eixos

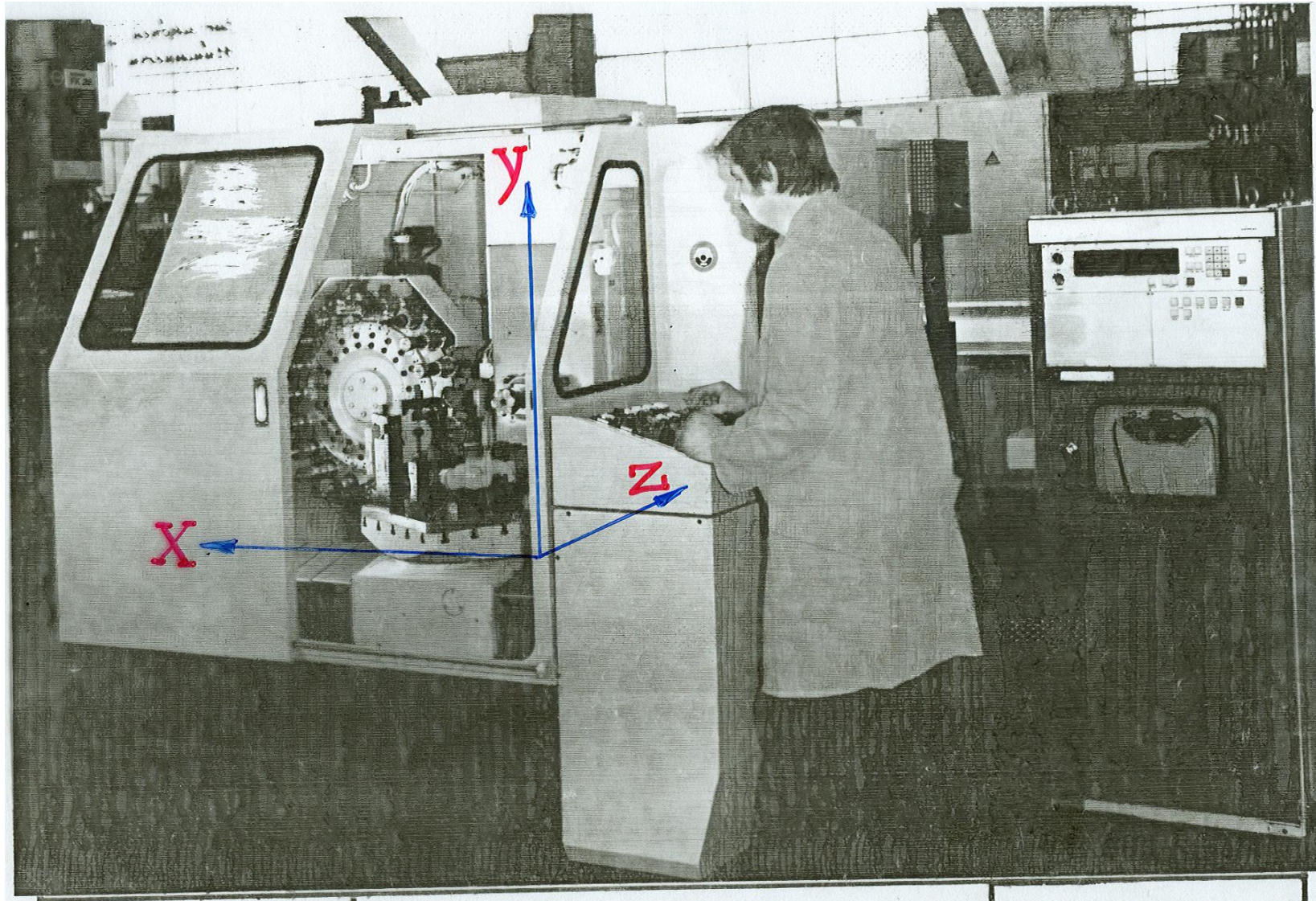

Centro de Usinagem de 3 Eixos

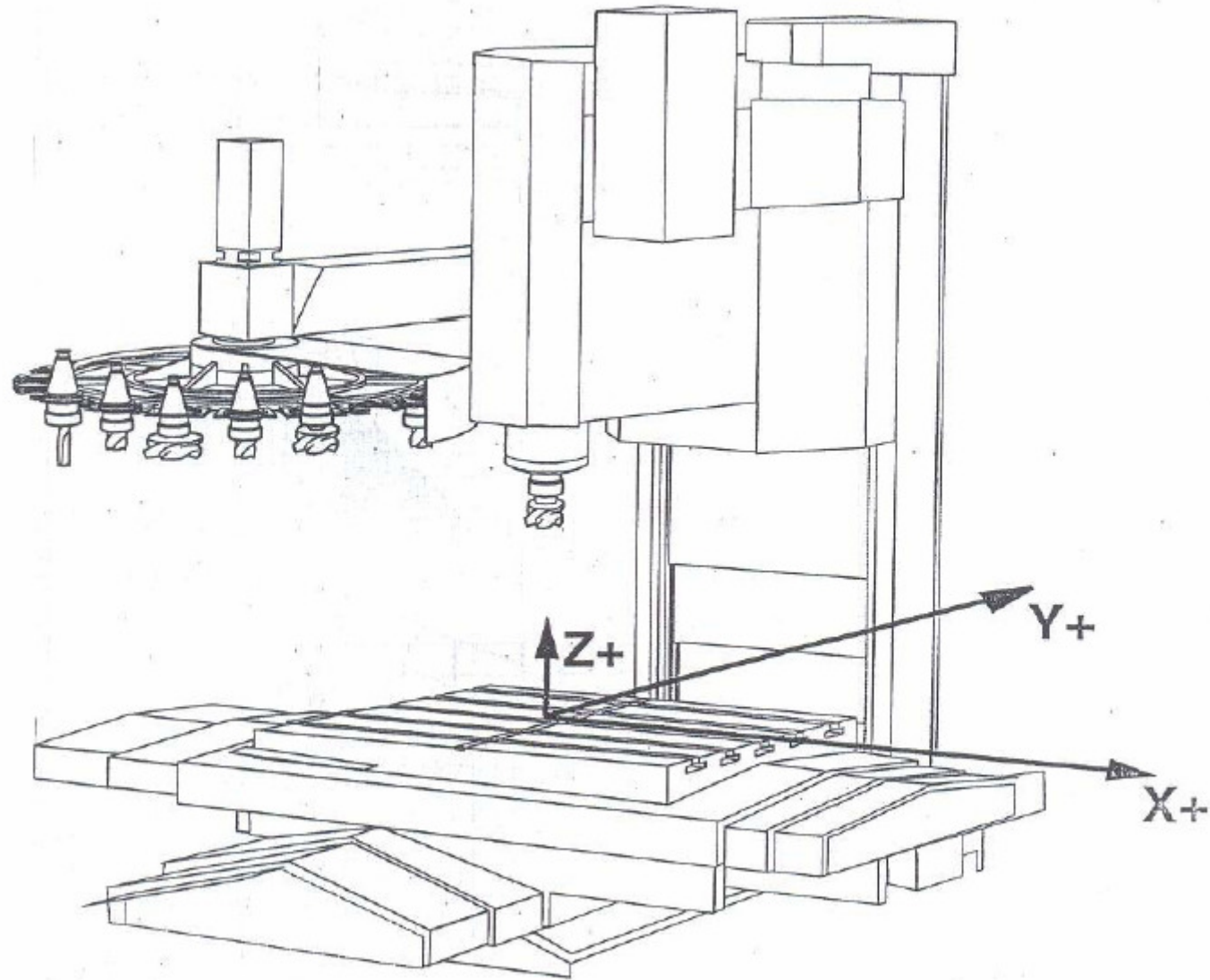

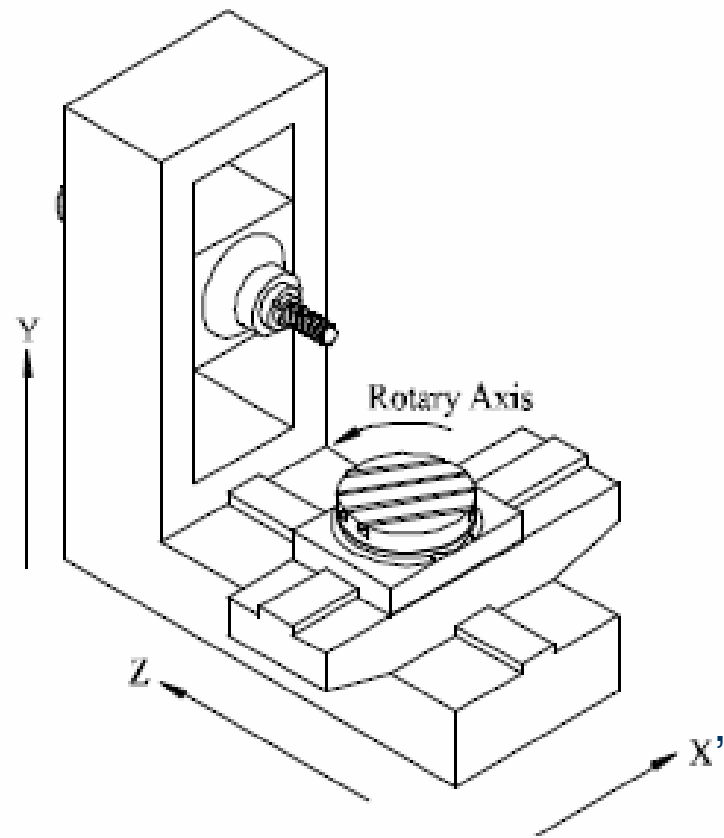

Horizontal Style

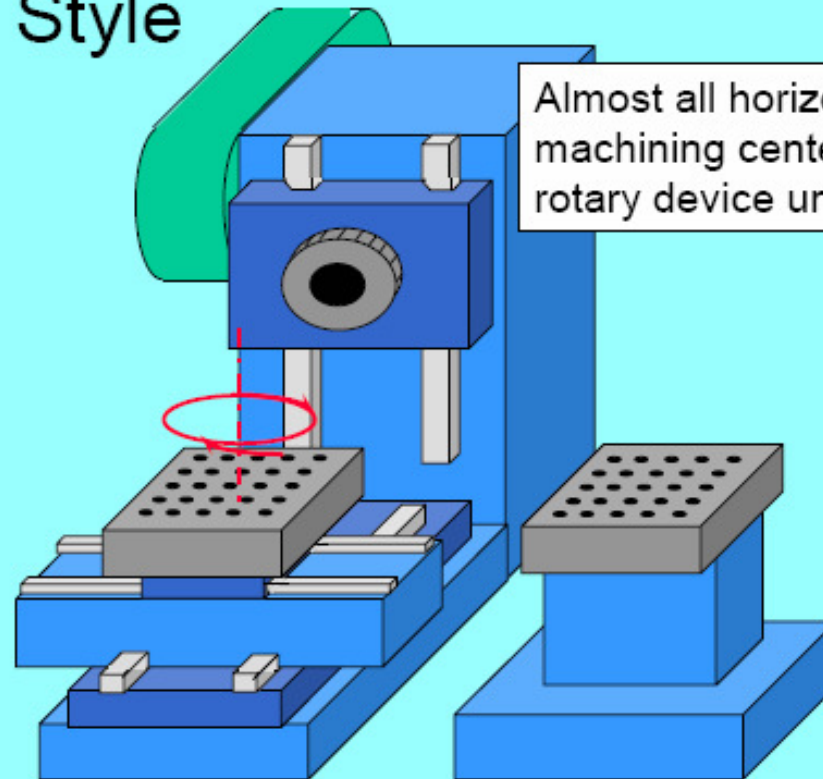

Almost all horizontal machining centers have a rotary device under the table



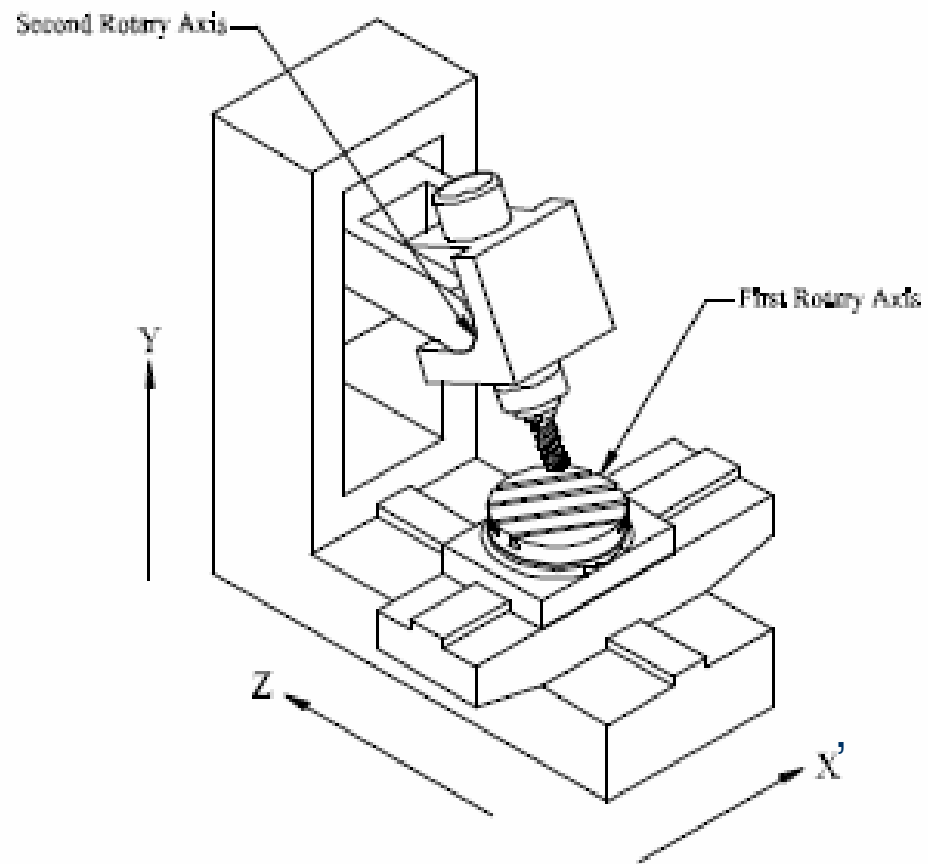

Mandriladoras

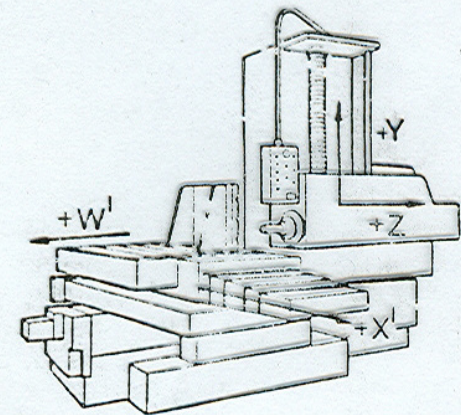
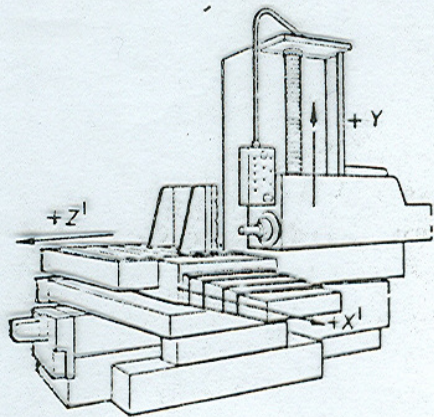

Gantry Style

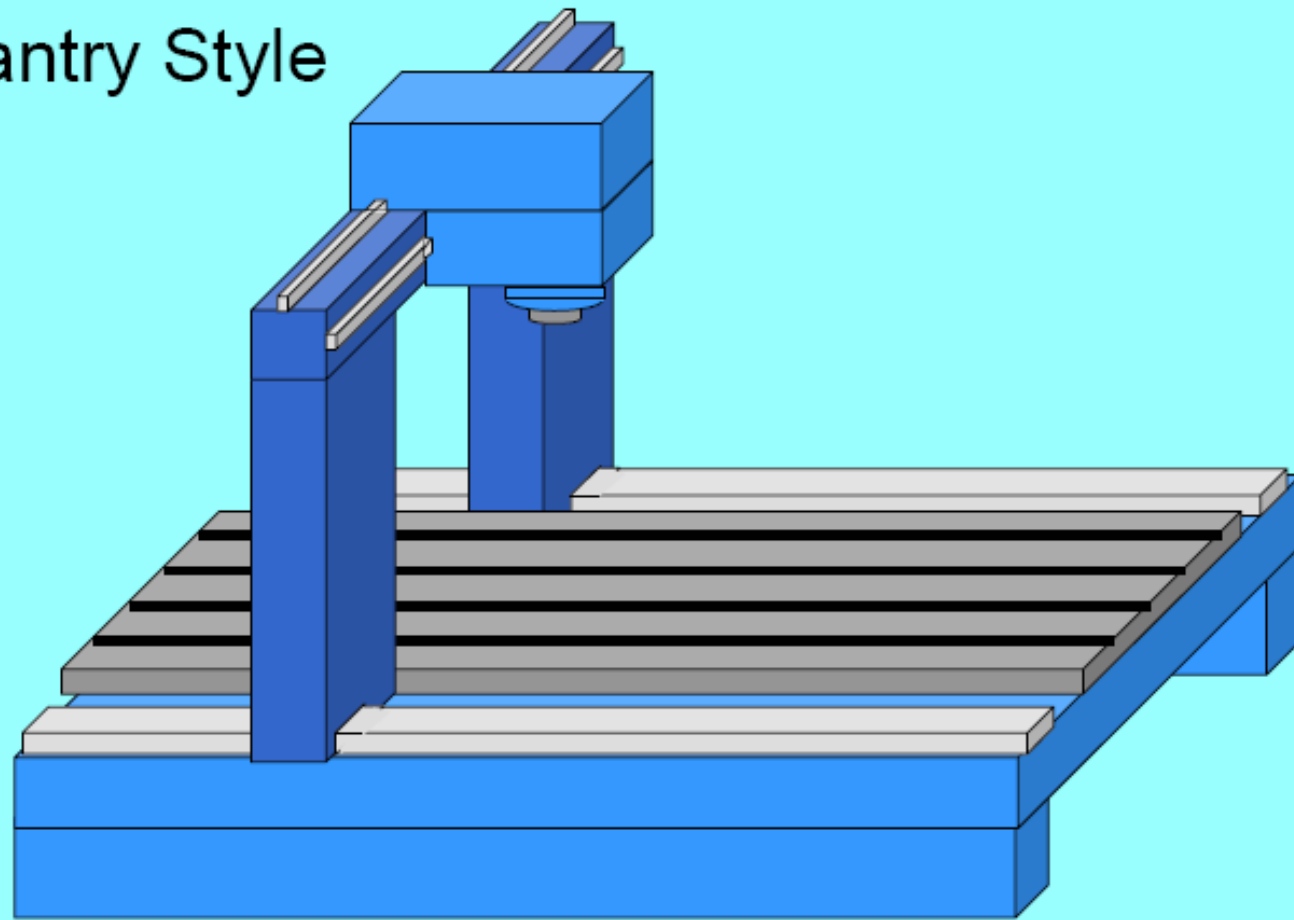

Gantry Style

Here is the polarity for each axis

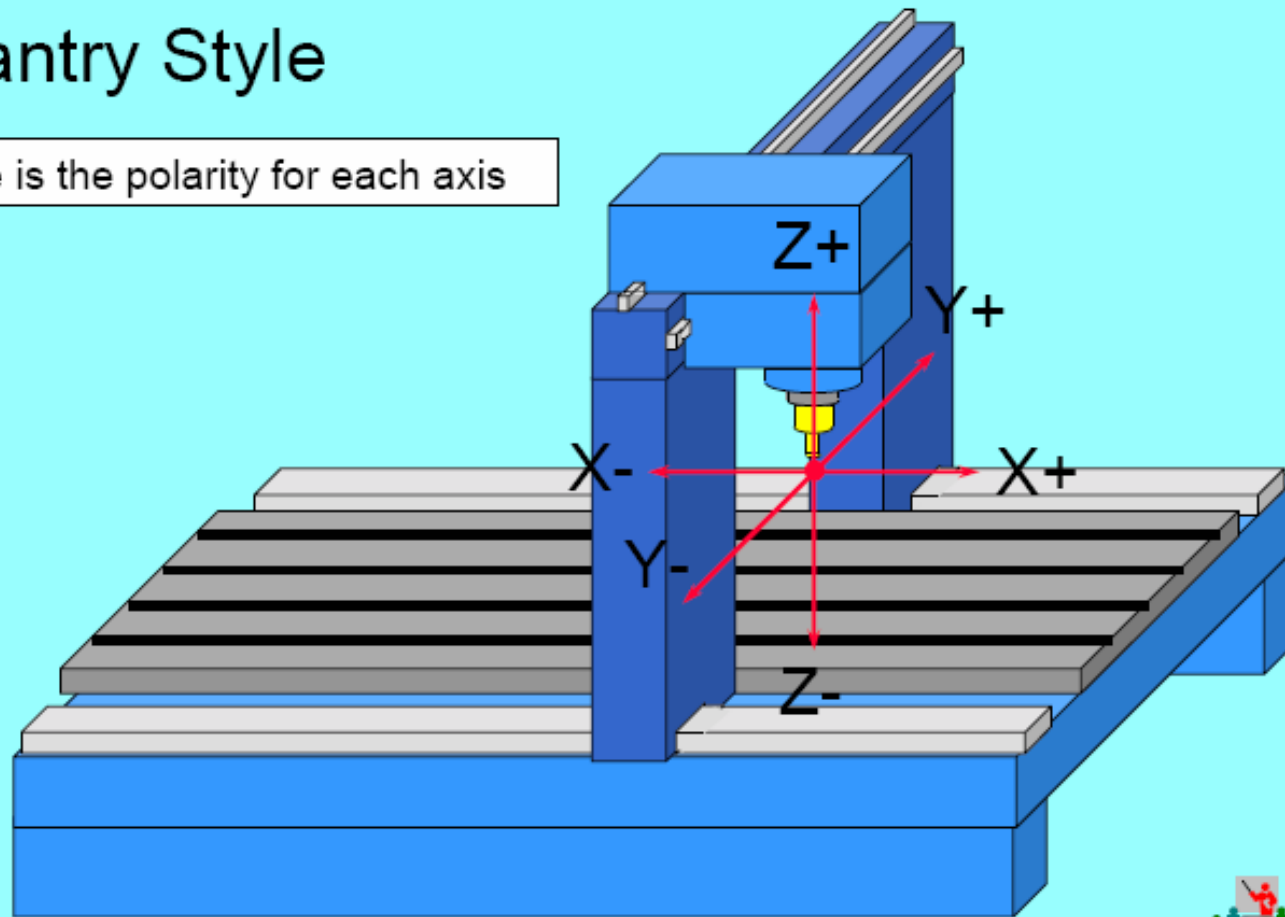

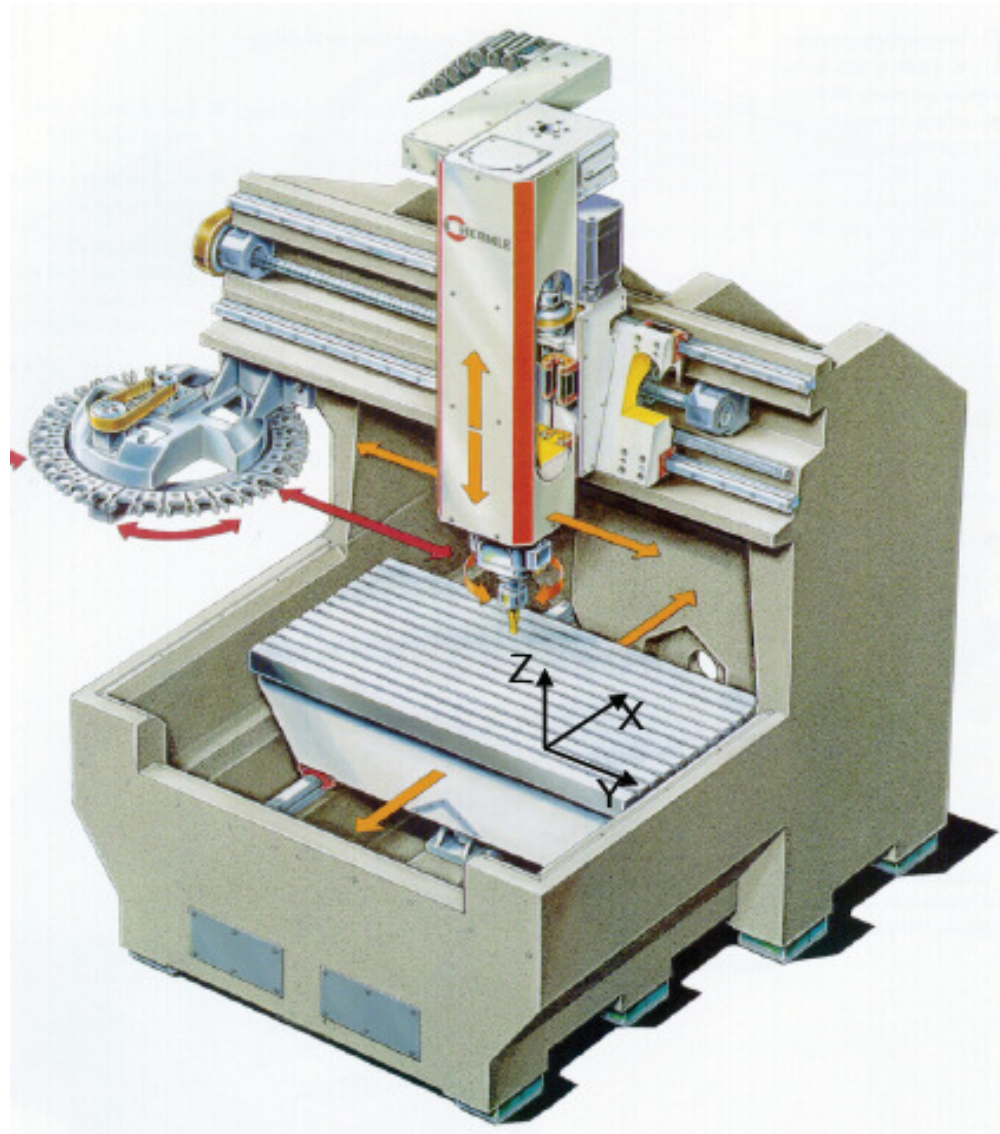

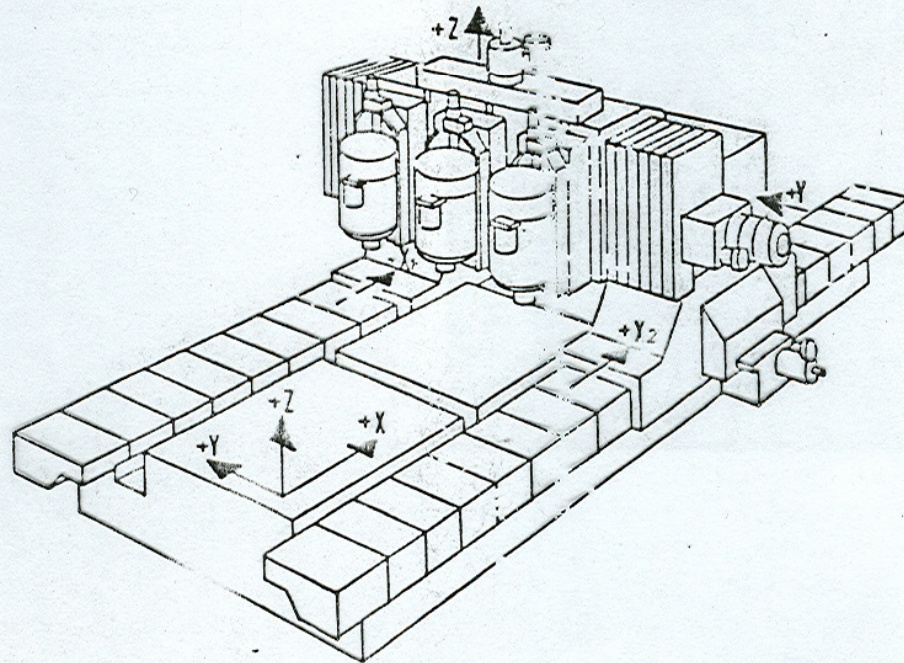
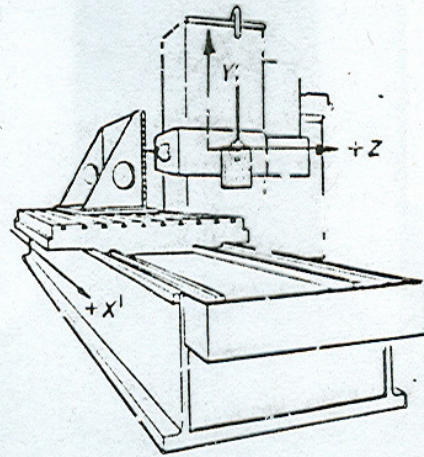
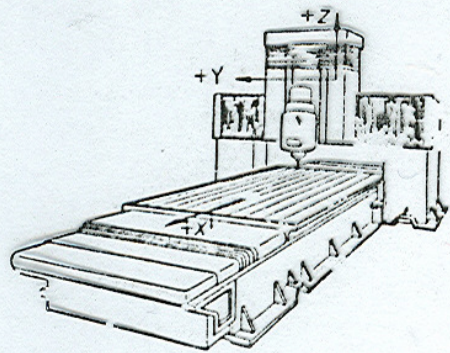

Fresadoras



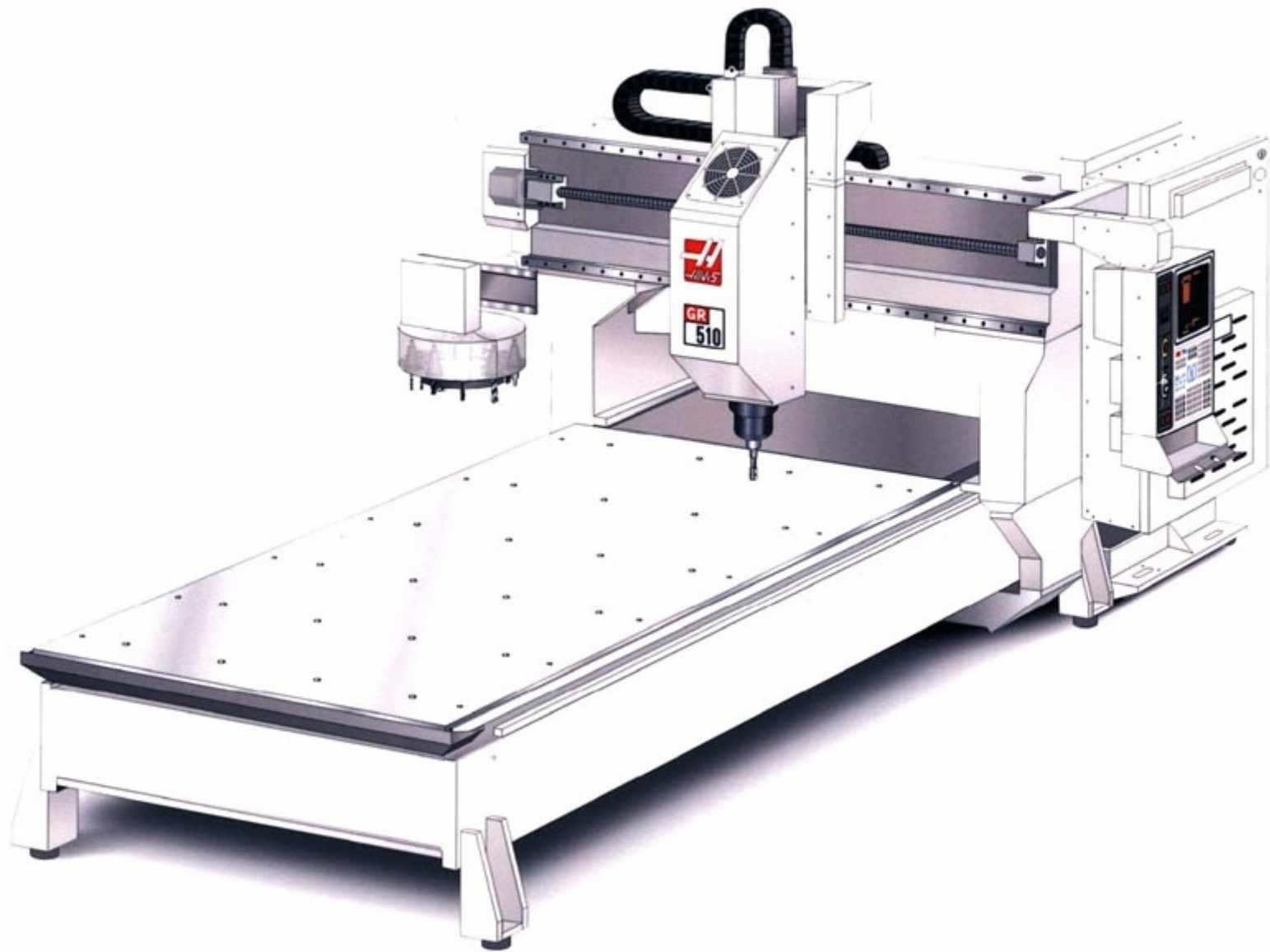



[Video 1](#)

[Video 2](#)

[Video 3](#)

Eixos de um Centro de Usinagem

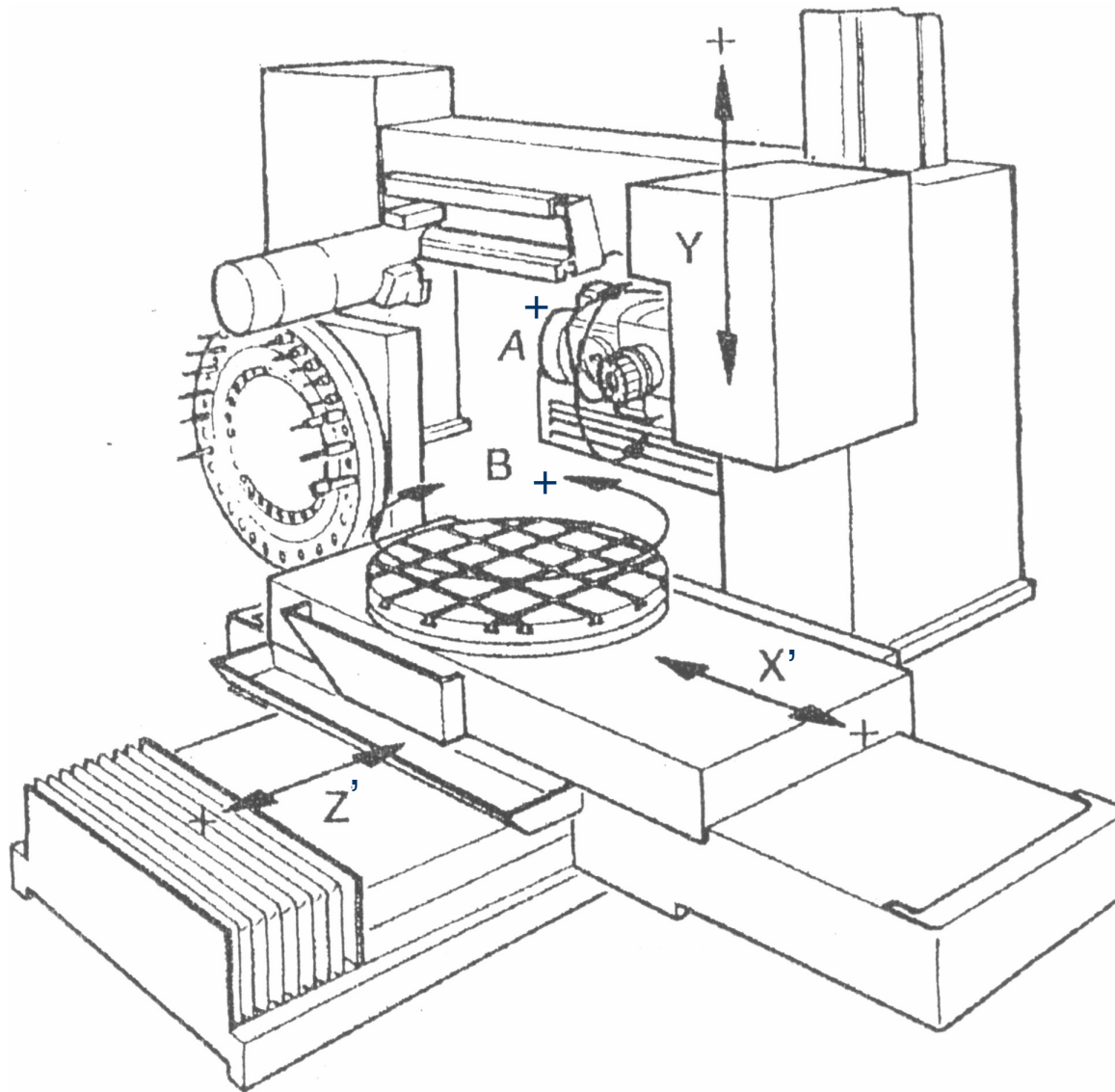

Representação dos eixos em um centro de usinagem com 3 eixos lineares e 2 rotacionais

Fresadoras de 5 Eixos

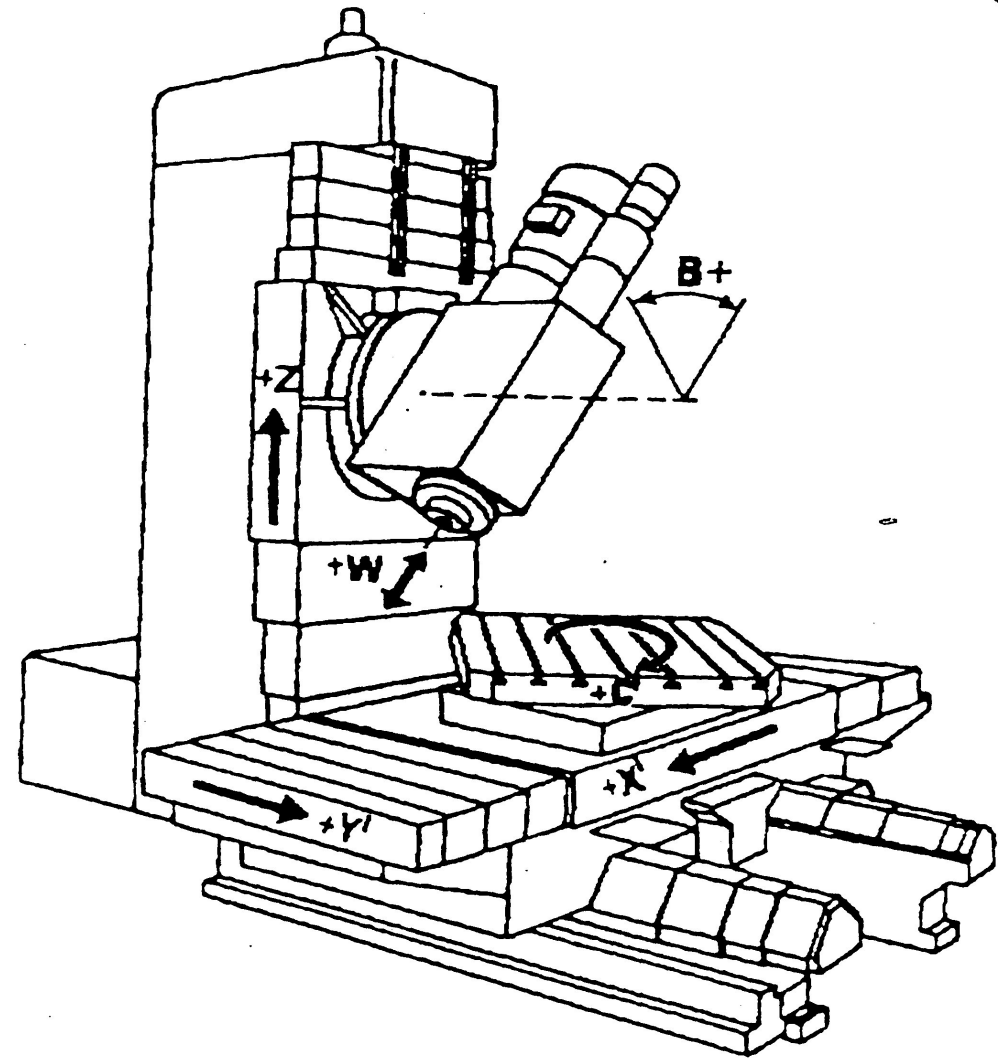
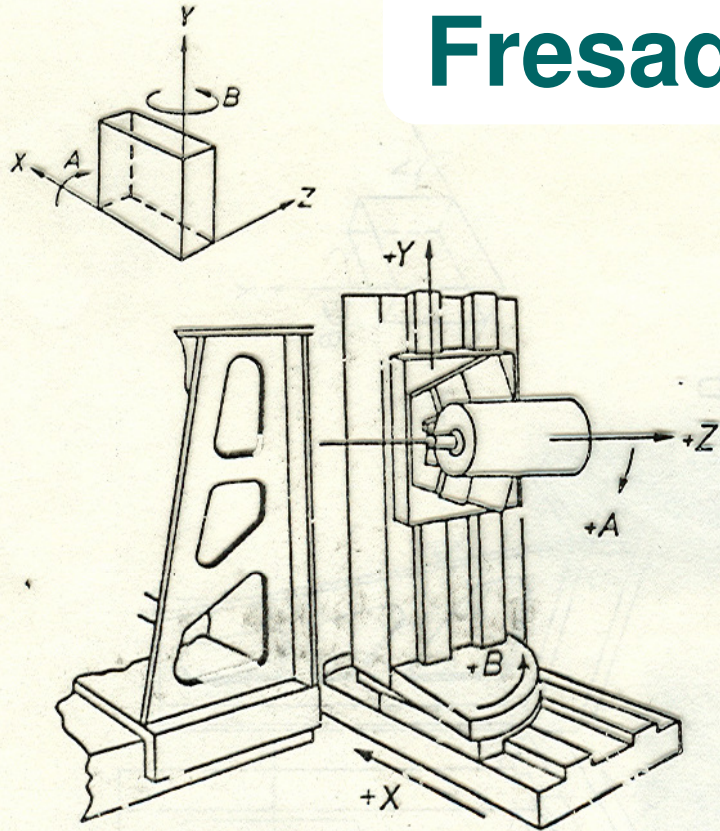

Fresadoras de 5 Eixos

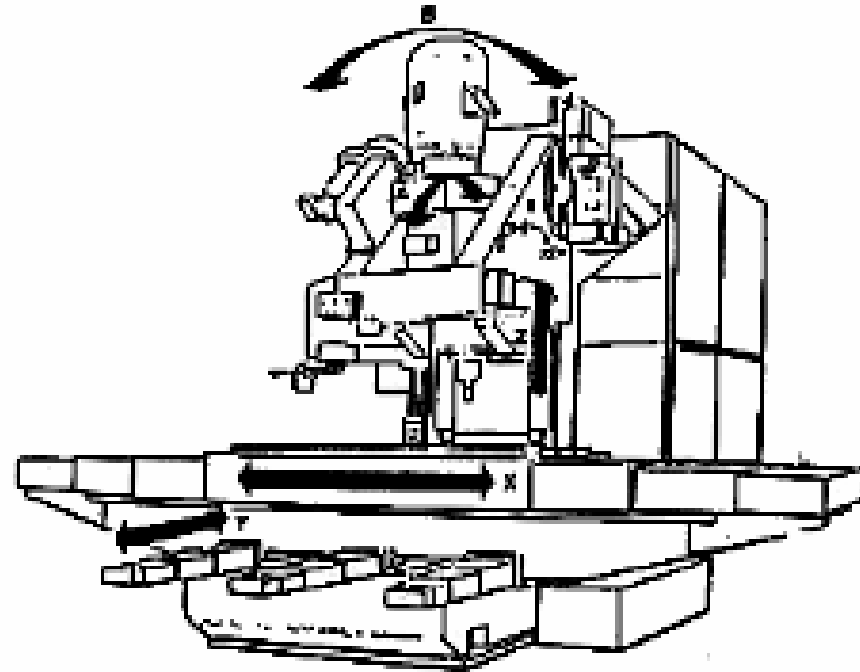
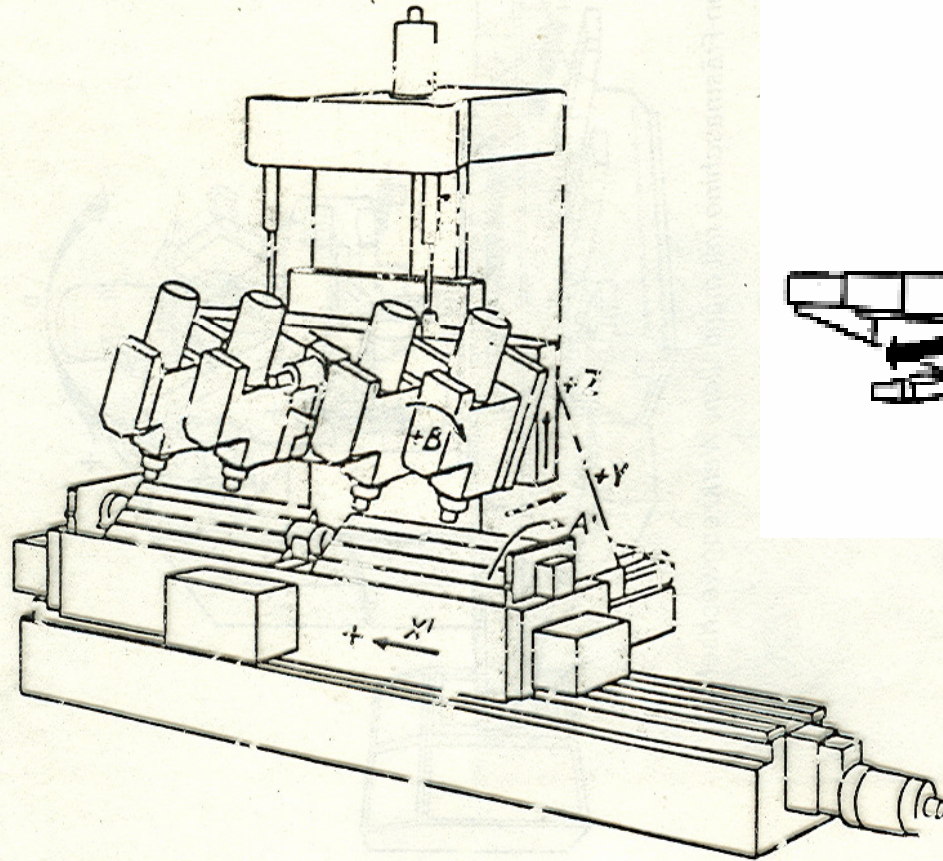

Fresadora de 5 Eixos

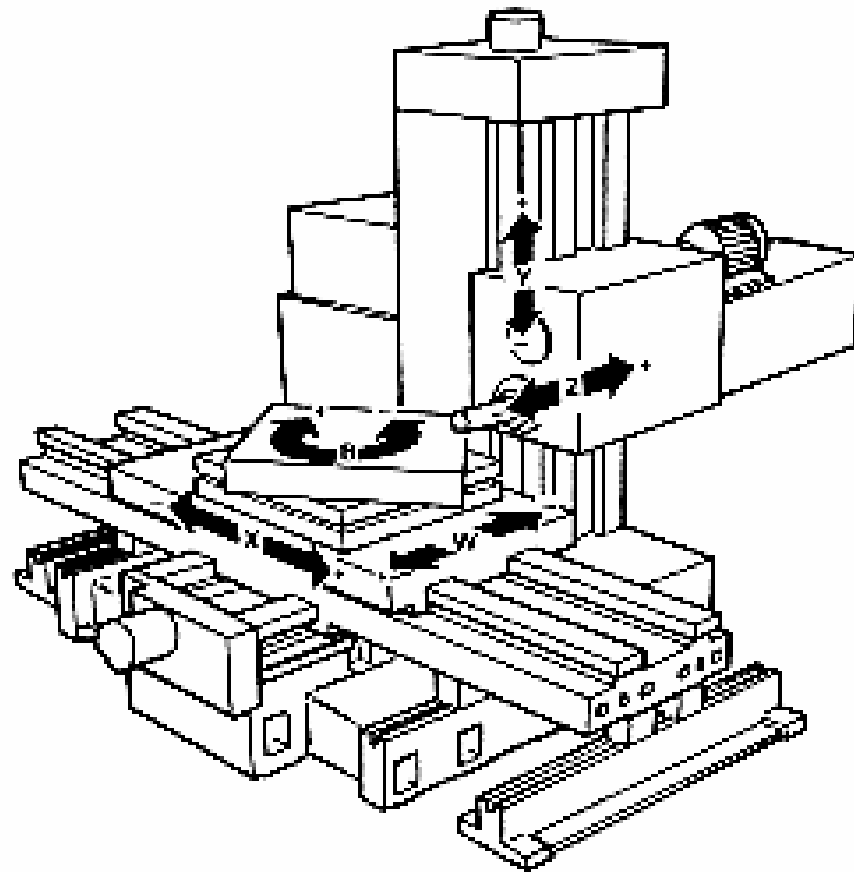



© K&H Manufacturing Design Systems, Inc.
All Rights Reserved.

C-frame style

Indexer

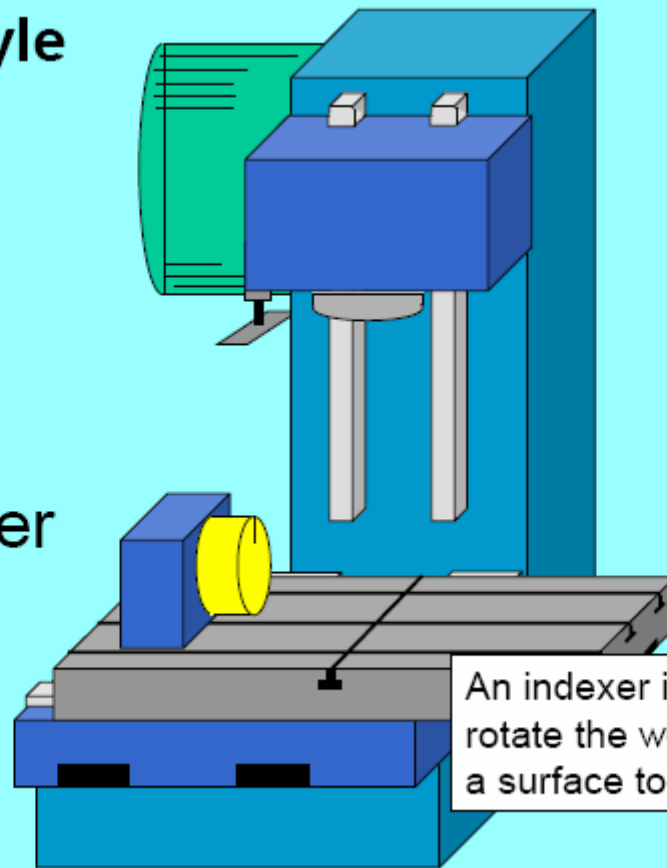

An indexer is used to quickly rotate the workpiece to expose a surface to the spindle



C-frame style

As viewed from above,
plus is clockwise...

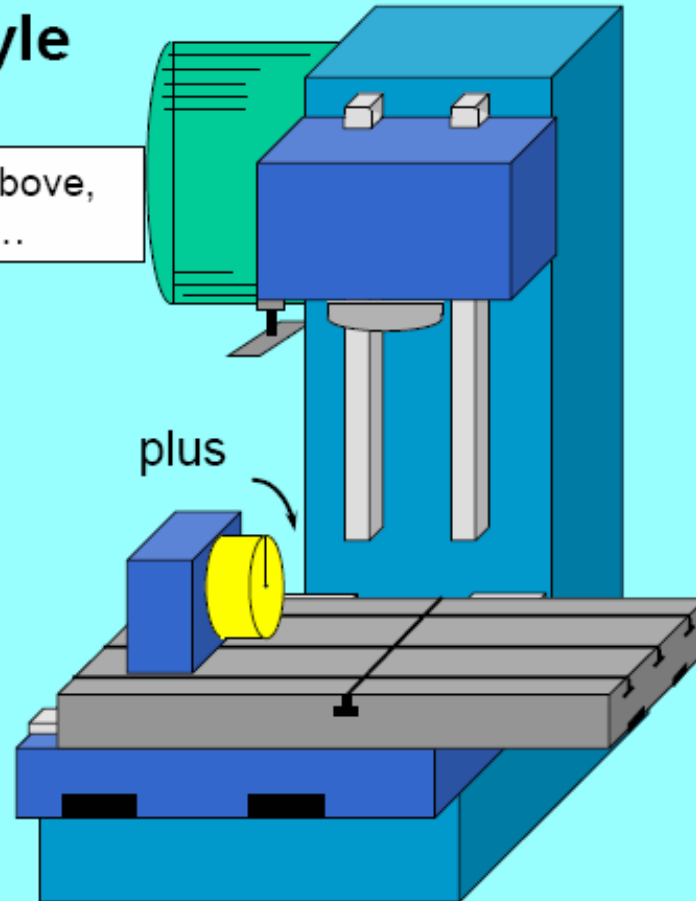

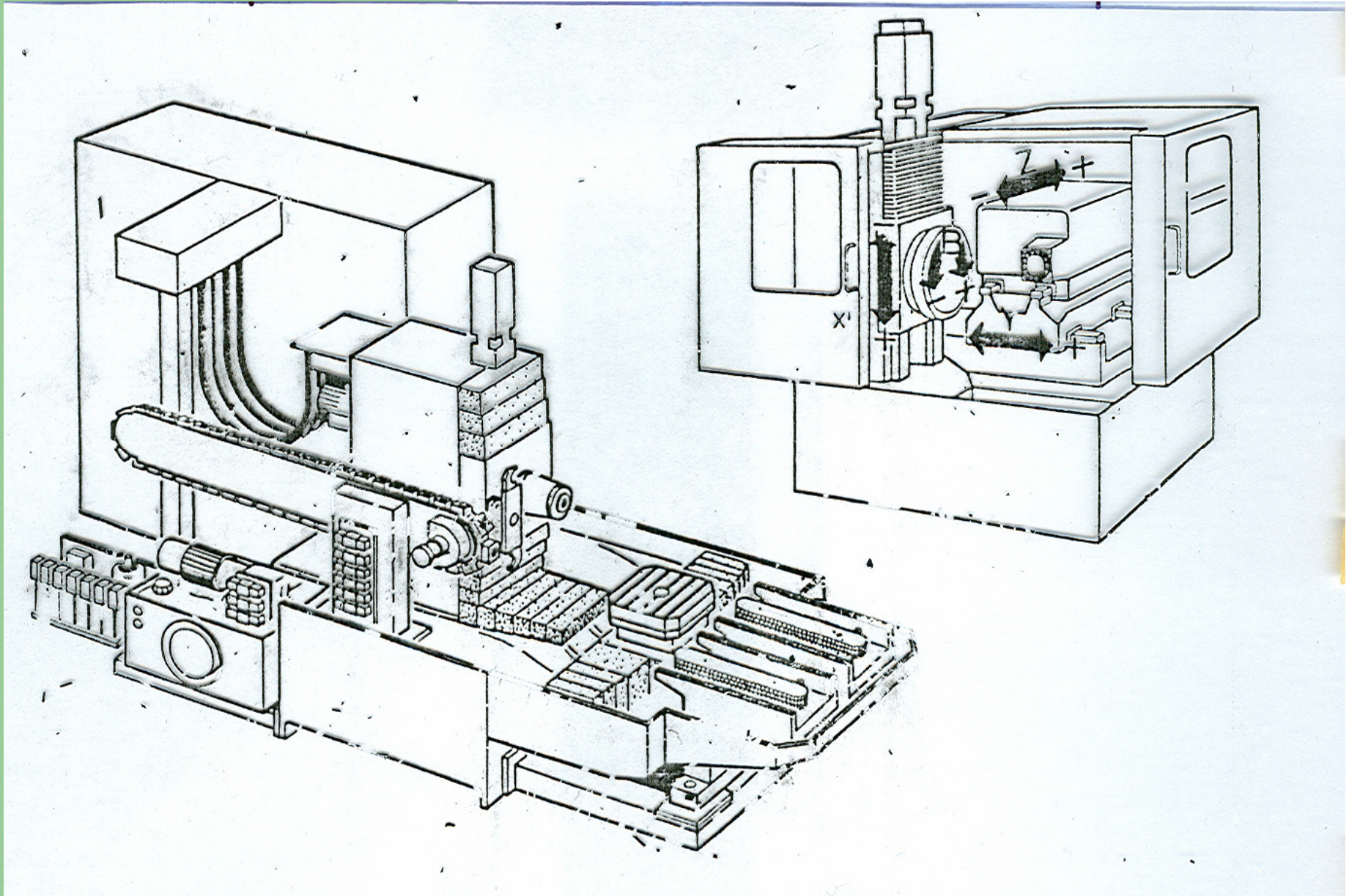

Centros de usinagem

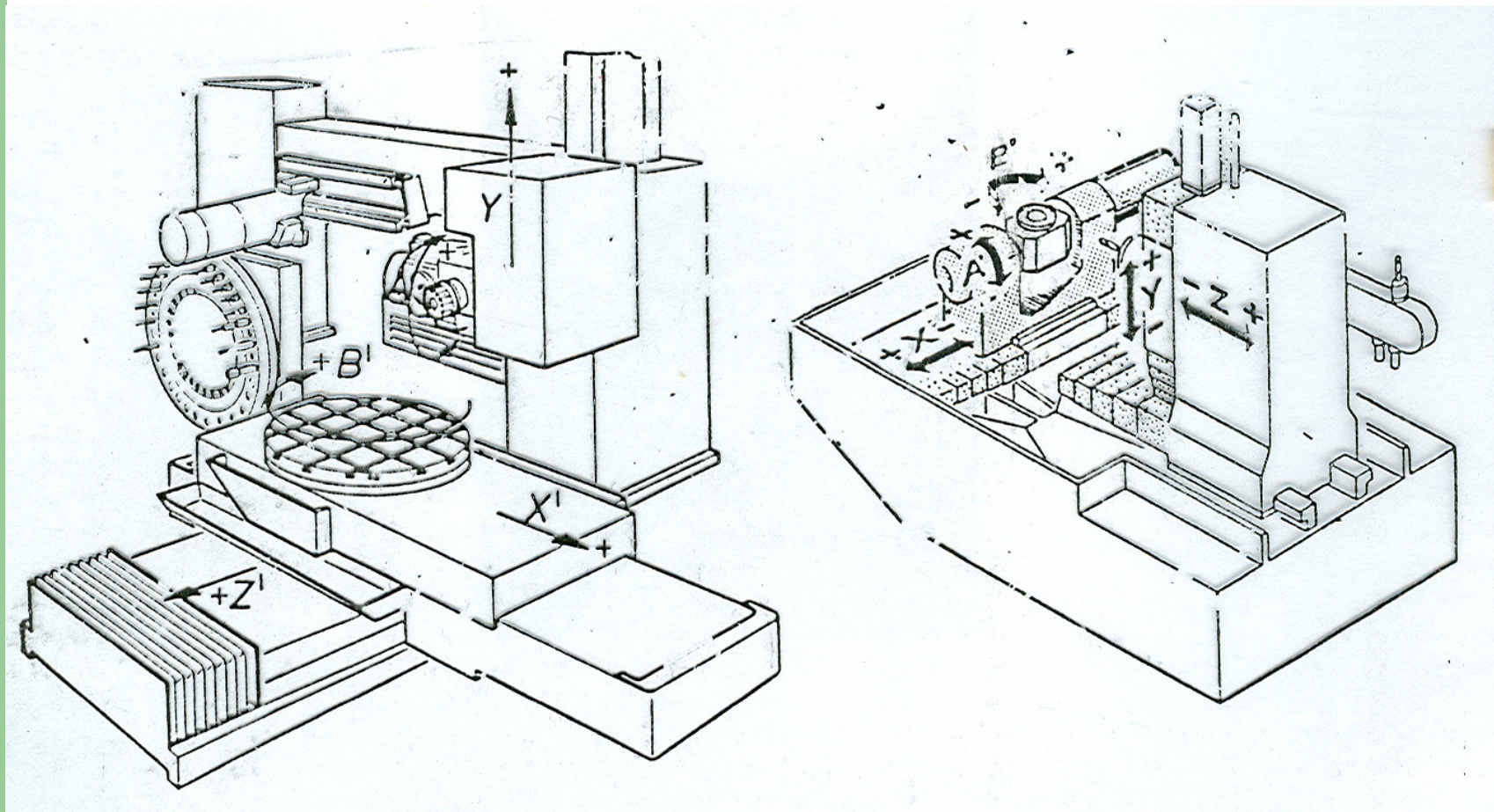

Centros de usinagem

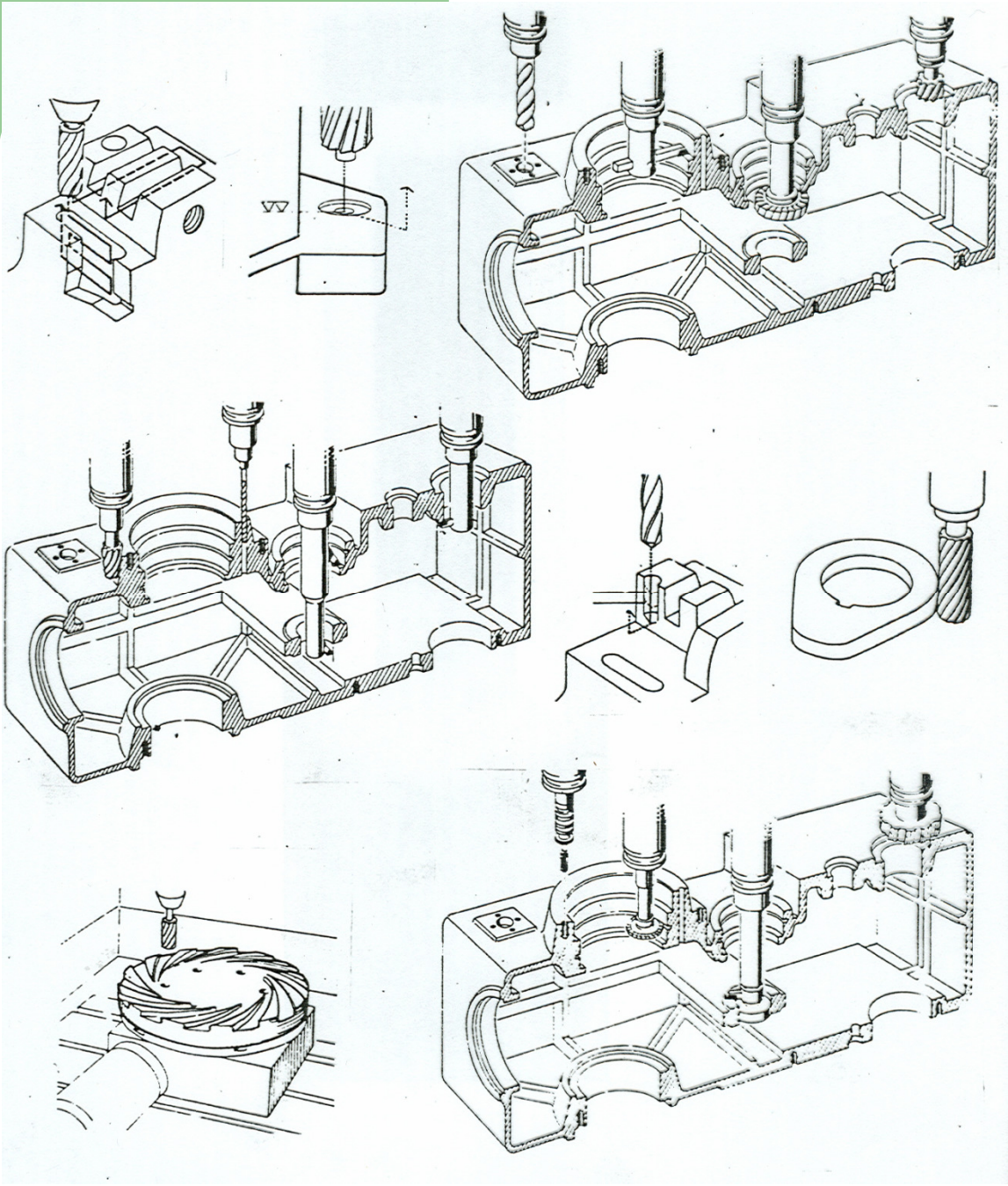

Exemplos de operações com centro de usinagem

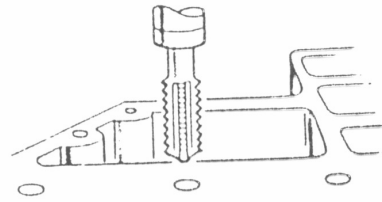

Rosqueamiento
(Cualquier ángulo)

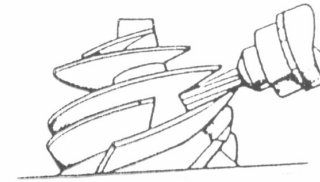

Fresado complejo

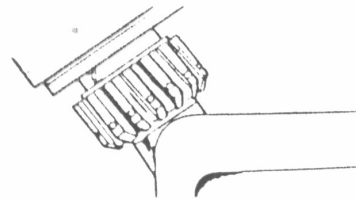

Fresado angular

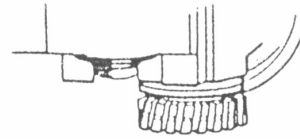

Fresado pesado

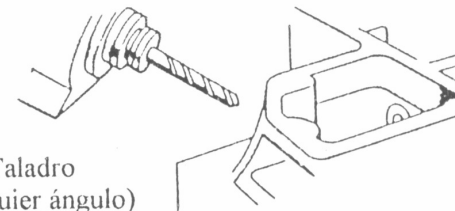

Taladro
(cualquier ángulo)

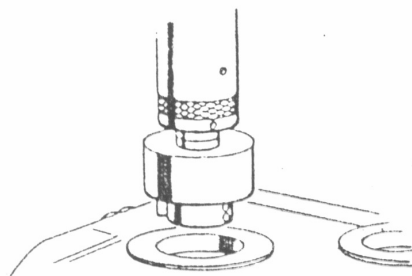

Mandrinado

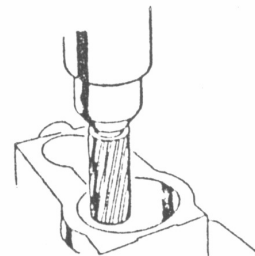

Fresado de topo

Recursos de um centro
de usinagem de 5
eixos

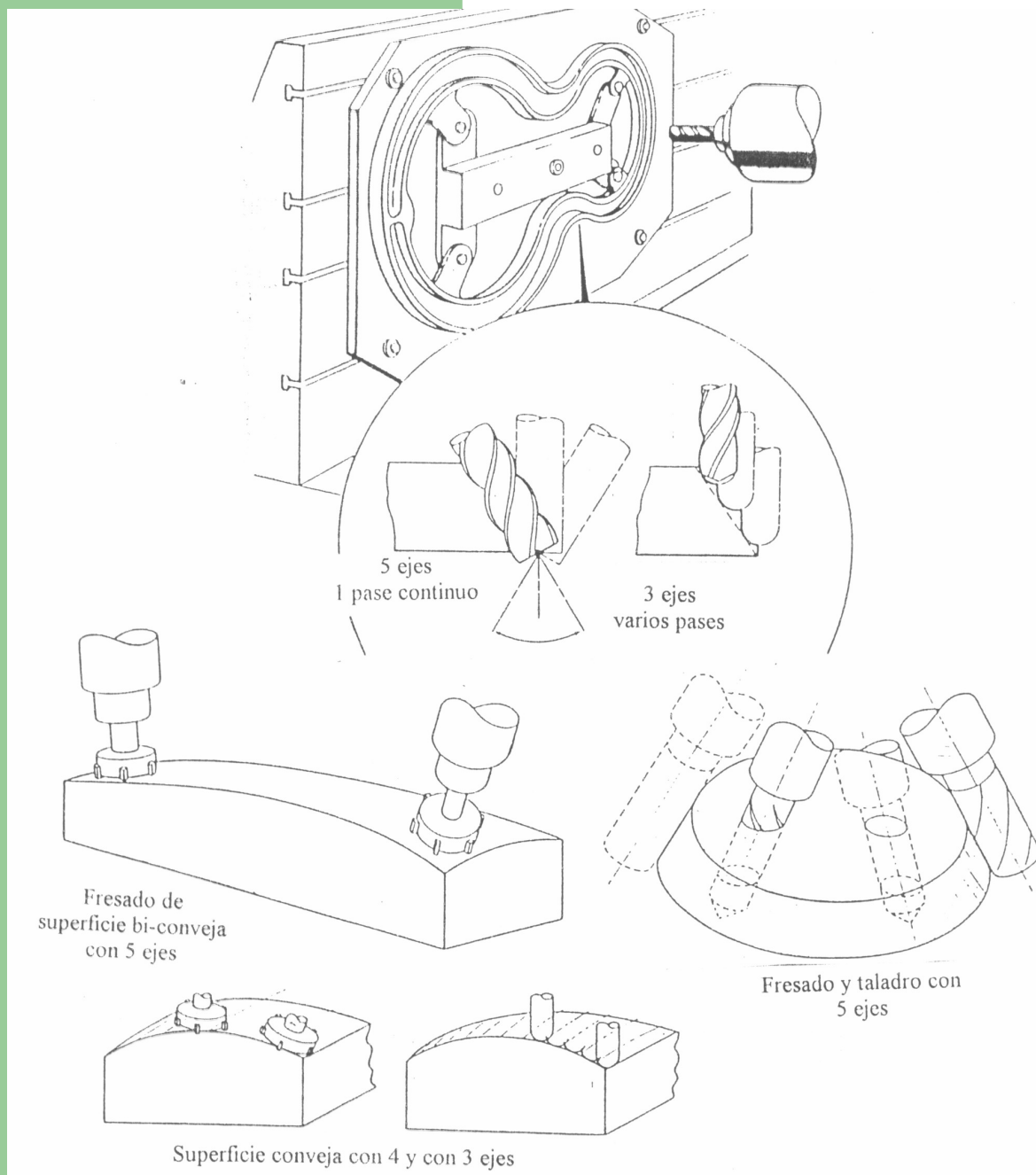

Usinagem de formas complexas em centros de usinagem com 3, 4 e 5 eixos

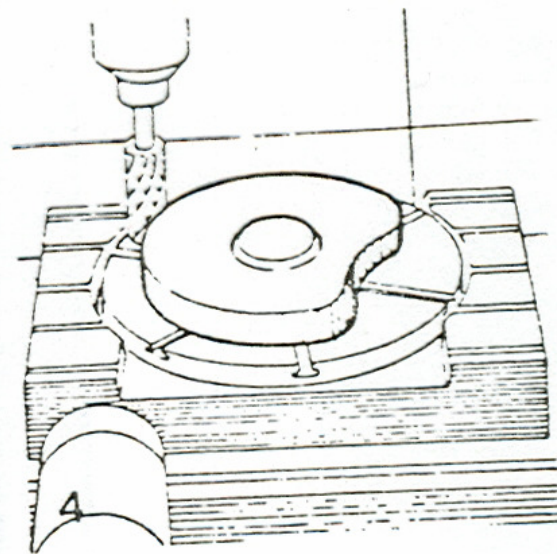
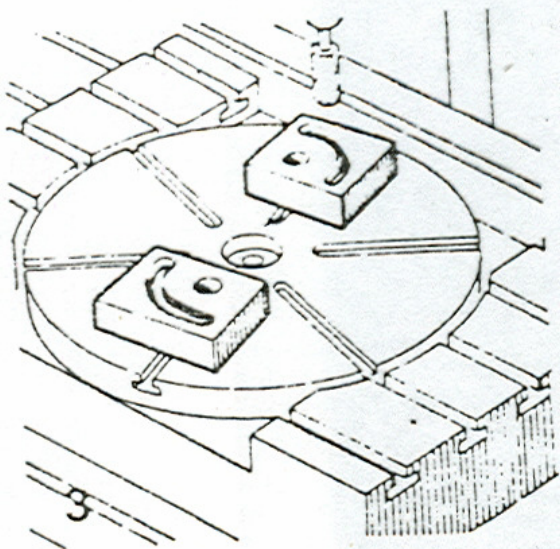
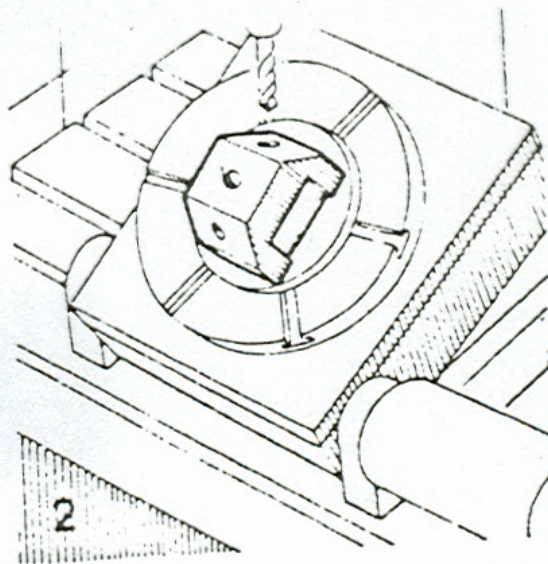
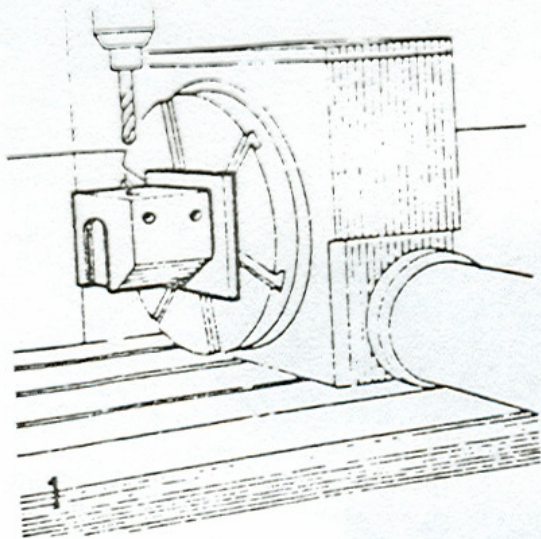

Exemplos de
operações com
centro de usinagem

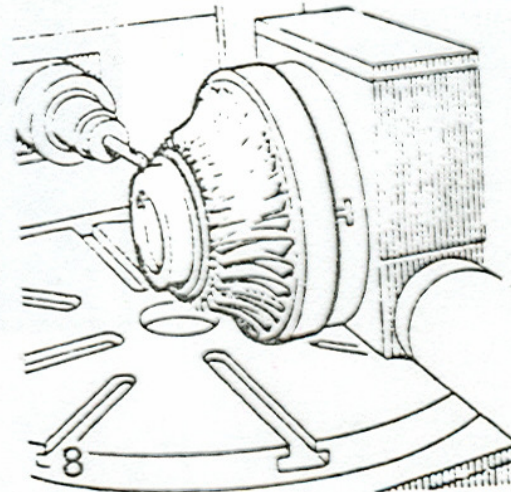
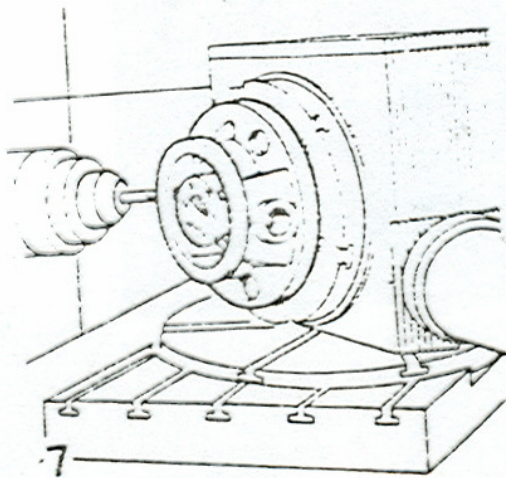
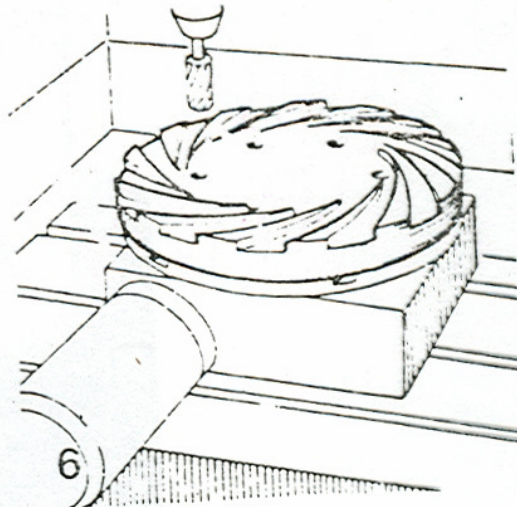
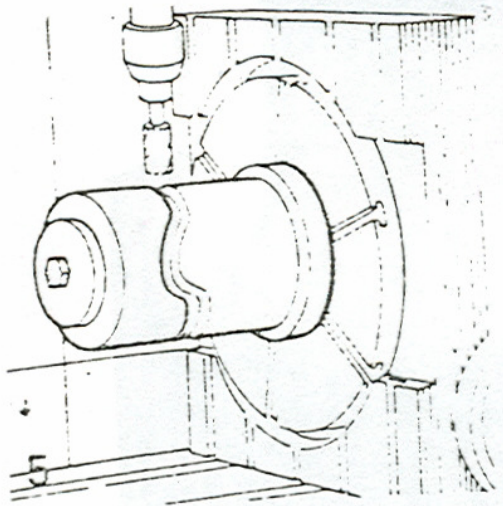

Exemplos de
operações com
centro de usinagem

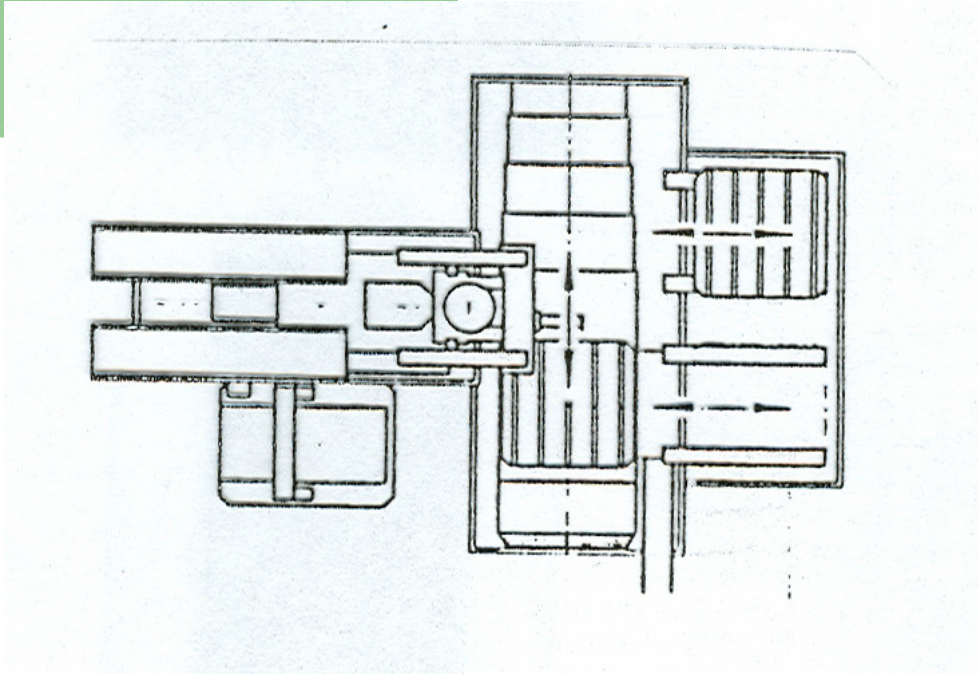

Centro de usinagem
com 2 pallets

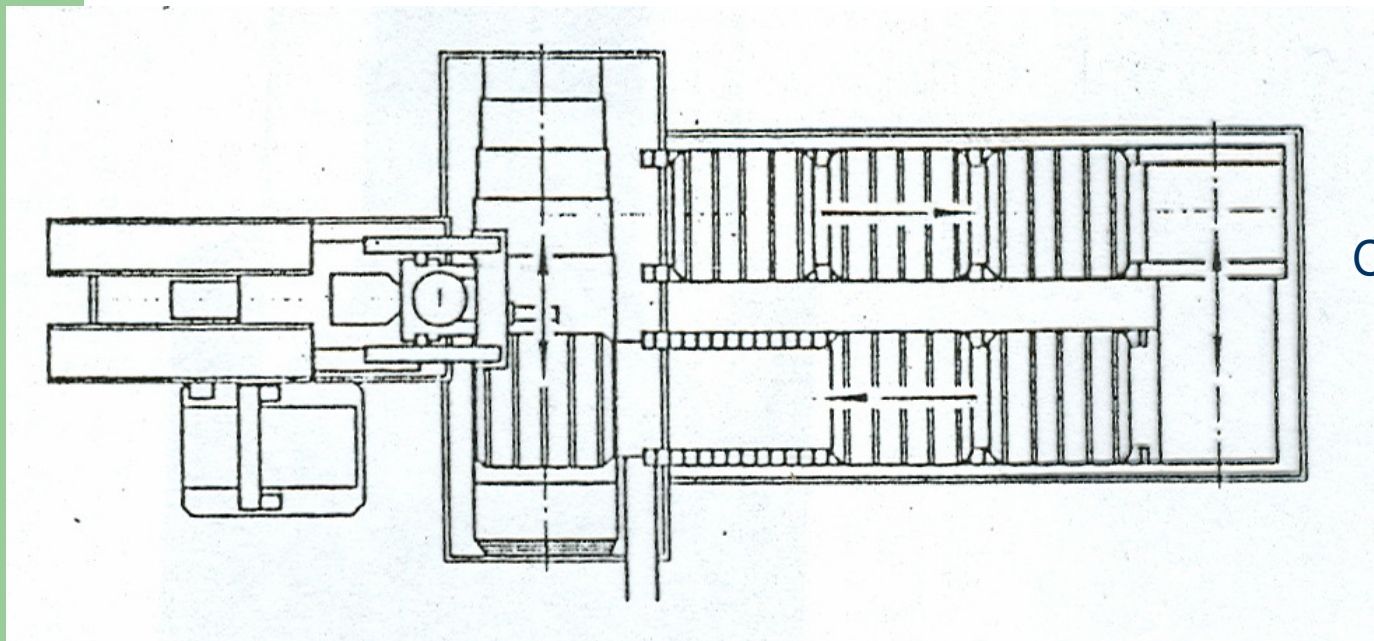

Centro de usinagem
com 6 pallets

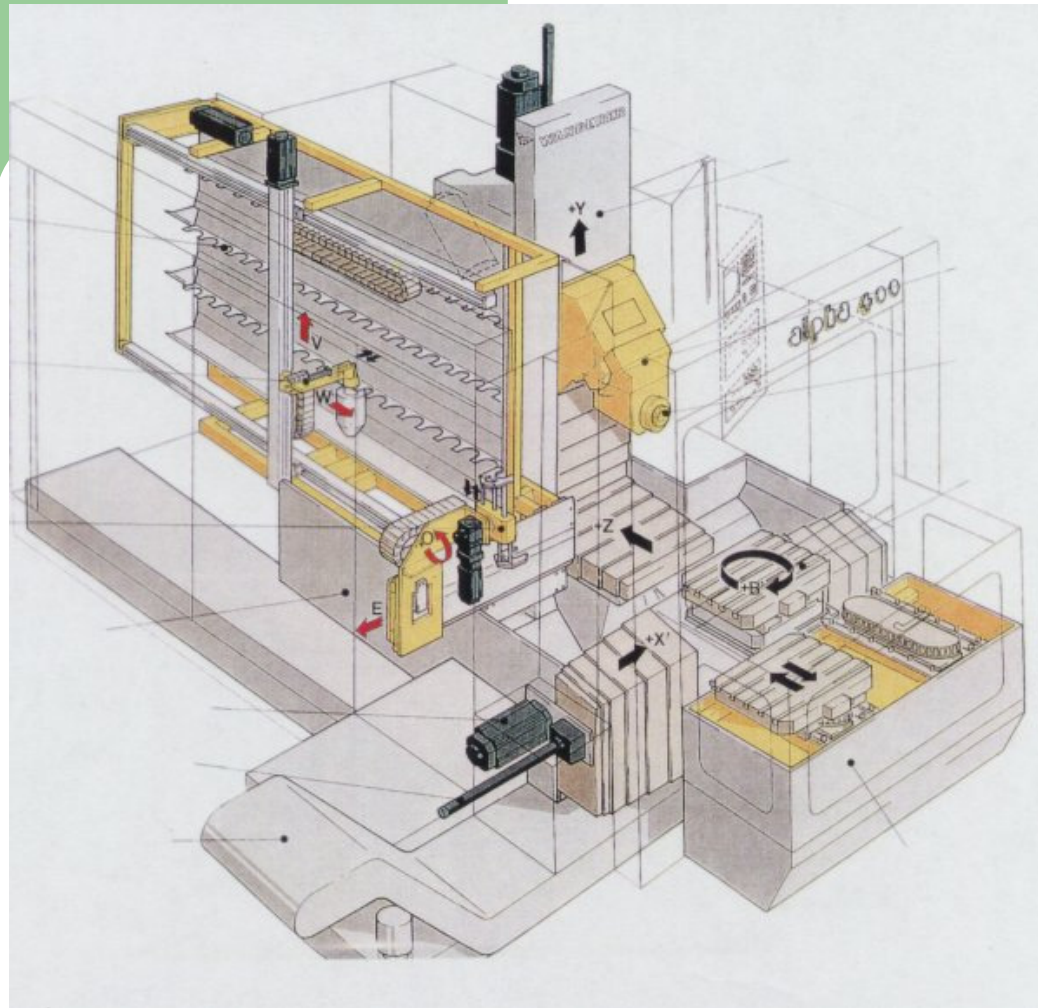

Centro de usinagem
de 4 eixos –
Recursos de fixação

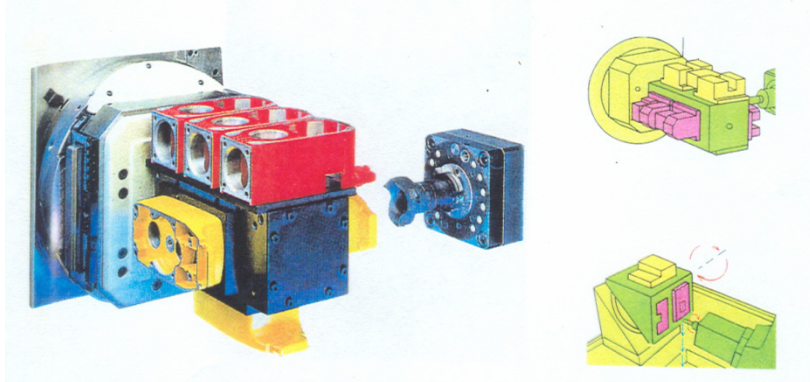

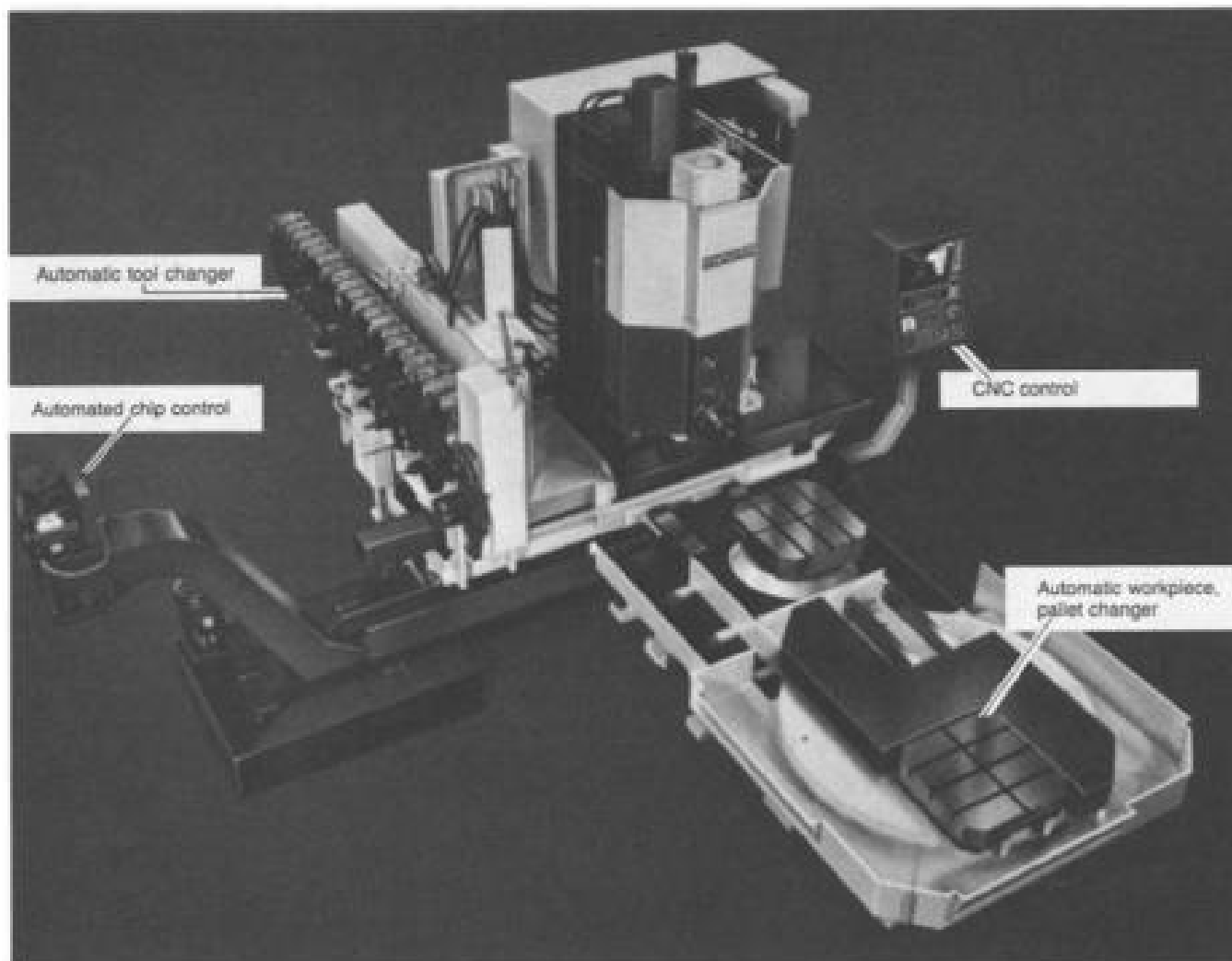

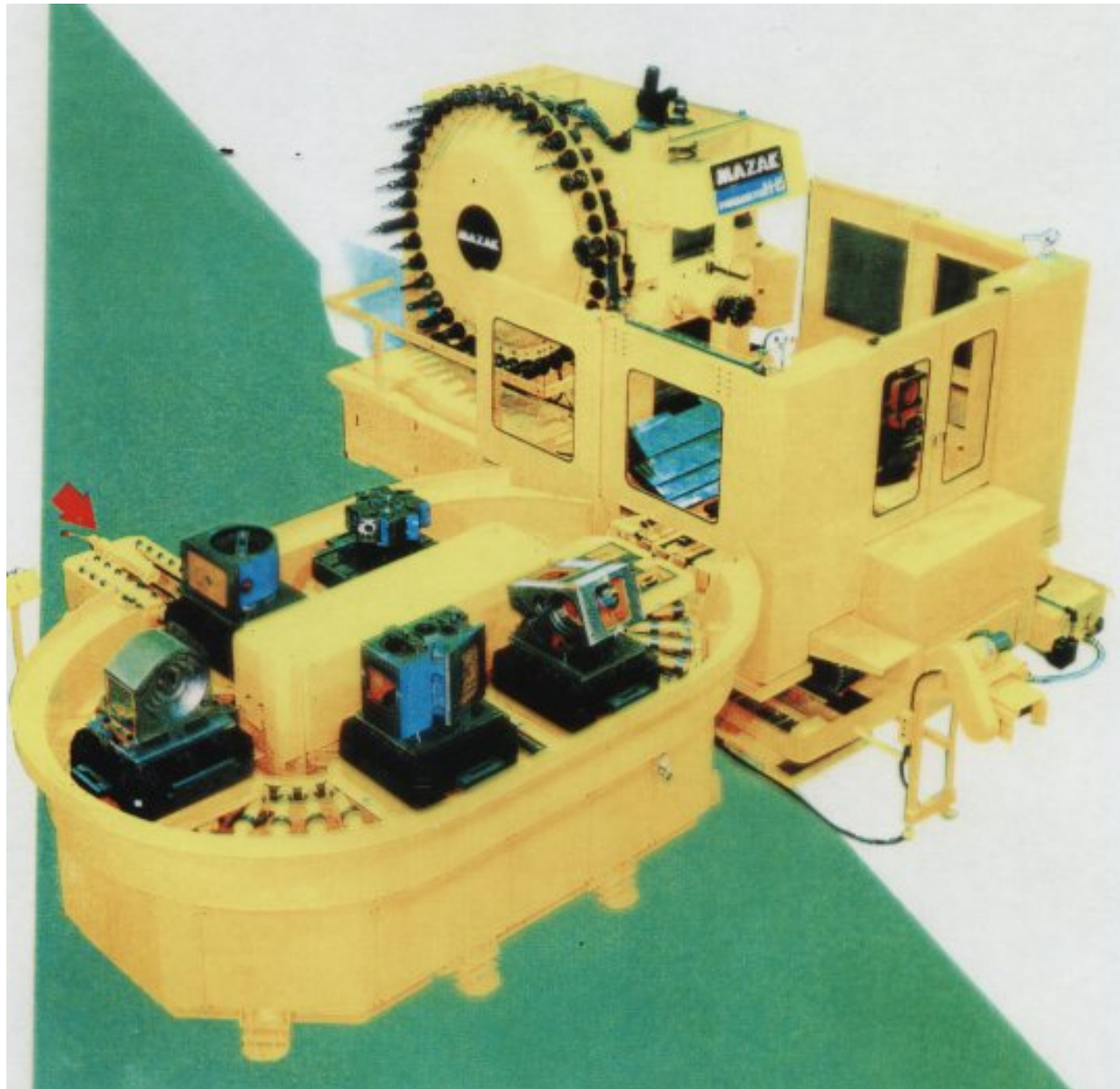

Alimentação
de pallets



Troca de
ferramentas

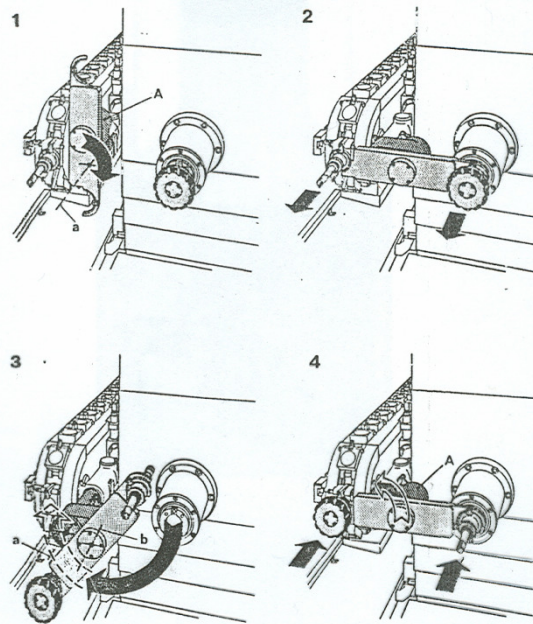
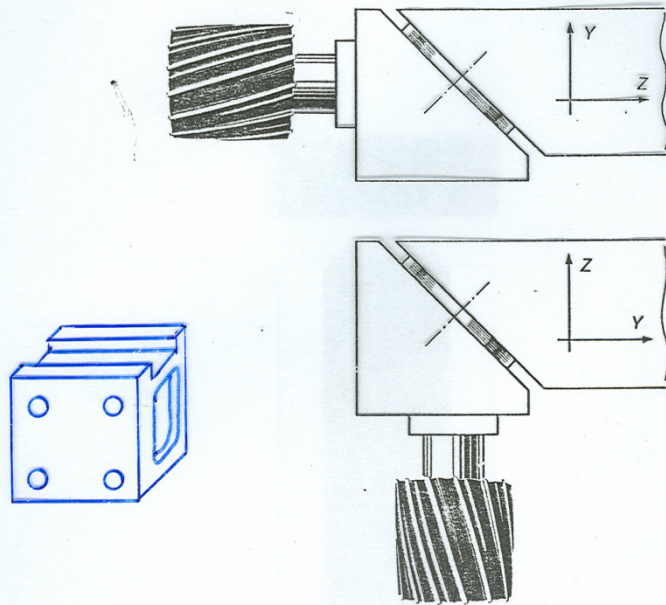

Troca de
ferramentas

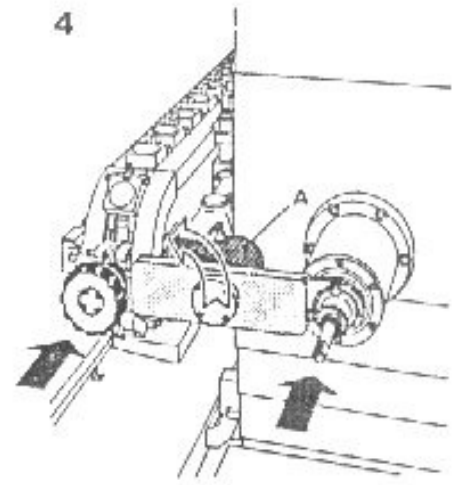
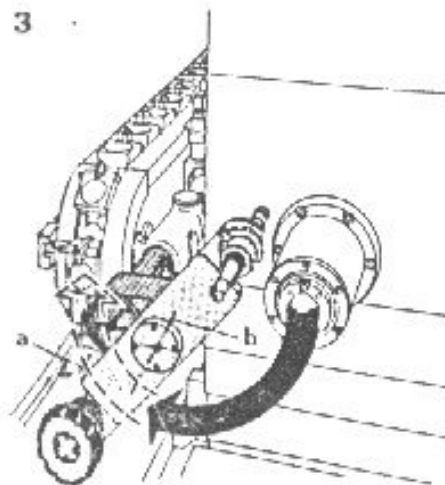
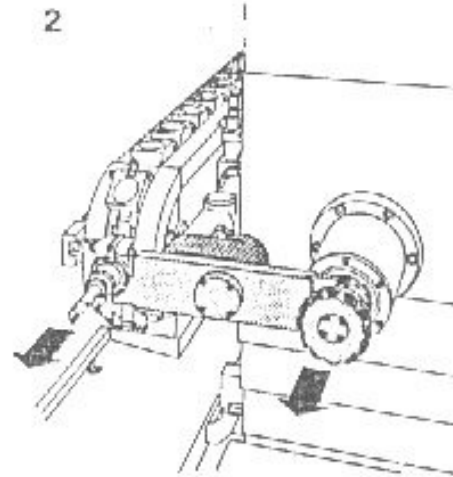
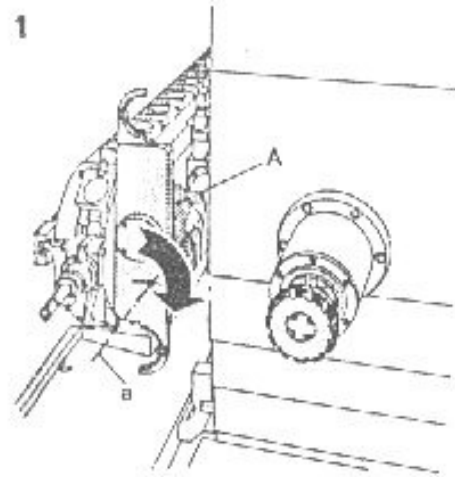

Troca de
ferramentas