

smar

FIRST IN FIELDBUS

MB-700

USER'S MANUAL

Modbus RTU and TCP/IP Processor



MAY / 05
MB-700



smar

web: www.smar.com

**Specifications and information are subject to change without notice.
For the latest updates, please visit the SMAR website above.**

BRAZIL

Smar Equipamentos Ind. Ltda.
Rua Dr. Antonio Furlan Jr., 1028
Sertãozinho SP 14170-480
Tel.: +55 16 3946-3510
Fax: +55 16 3946-3554
e-mail: insales@smar.com.br

GERMANY

Smar GmbH
Rheingaustrasse 9
55545 Bad Kreuznach
Germany
Tel: + 49 671-794680
Fax: + 49 671-7946829
e-mail: infoservice@smar.de

USA

Smar International Corporation
6001 Stonington Street, Suite 100
Houston, TX 77040
Tel.: +1 713 849-2021
Fax: +1 713 849-2022
e-mail: sales@smar.com

CHINA

Smar China Corp.
3 Baishiqiao Road, Suite 30233
Beijing 100873, P.R.C.
Tel.: +86 10 6849-8643
Fax: +86-10-6894-0898
e-mail: info@smar.com.cn

MEXICO

Smar Mexico
Cerro de las Campanas #3 desp 119
Col. San Andrés Atenco
Tlalnepantla Edo. Del Méx - C.P. 54040
Tel.: +53 78 46 00 al 02
Fax: +53 78 46 03
e-mail: ventas@smar.com

FRANCE

Smar France S. A. R. L.
42, rue du Pavé des Gardes
F-92370 Chaville
Tel.: +33 1 41 15-0220
Fax: +33 1 41 15-0219
e-mail: smar.am@wanadoo.fr

SINGAPORE

Smar Singapore Pte. Ltd.
315 Outram Road
#06-07, Tan Boon Liat Building
Singapore 169074
Tel.: +65 6324-0182
Fax: +65 6324-0183
e-mail: info@smar.com.sg

NETHERLANDS

Smar Nederland
De Oude Wereld 116
2408TM Alphen aan den Rijn
Tel: +31 172 494 922
Fax: +31 172 479 888
e-mail : info@smarnederland.nl

UNITED KINGDOM

Smar UK Ltd
3, Overhill Road - Cirencester
Gloucestershire -
GL7 2LG
Tel: +44 (0)797 0094138
Fax: +44 (0)797 4747502
e-mail: info@smarUK.co.uk

Smar Laboratories Corporation

6001 Stonington Street, Suite 100
Houston, TX 77040
Tel.: +1 713 849-2021
Fax: +1 713 849-2022
e-mail: sales@smar.com

Smar Research Corporation

4250 Veterans Memorial Hwy. Suite 156
Holbrook , NY 11741
Tel: +1-631-737-3111
Fax: +1-631-737-3892
e-mail: sales@smarresearch.com

INTRODUCTION

The MB-700 is a powerful multifunction module from LC700 family that can be used isolated or integrated to the SYSTEM302. The module can perform multi function in MODBUS protocol like gateway MODBUS TCP/IP and MODBUS RTU, MODBUS data concentrator and Peer-to-Peer communication between MODBUS slave devices.

These are some of MB-700 characteristics:

- Tight integration with intelligent devices and software from multiple manufacturers due to use of open standards as OPC Server and Modbus TCP/IP and RTU;
- Totally integrated unit having the following functions: interface, gateway, linking device, bridge and MODBUS data concentrator;
- As Gateway Modbus. the MB-700 can work in both directions: as Gateway TCP/IP to Serial or Serial to TCP;
- As Data Concentrator the module can concentrate the data from the slaves in the serial and provide the data to TCP/IP via OPC or MODBUS TCP/IP;
- As Peer-to-Peer can exchange MODBUS data between slaves connected in the TCP/IP, Serial or both Medias;
- Full redundancy and fault isolation for high safety and uninterrupted operation.

TABLE OF CONTENTS

Introduction.....	III
Glossary.....	IX
References.....	XIII
Chapter 1 - Overview.....	1.1
Main characteristics	1.2
System Integration	1.3
Power Supply – PS-AC-R	1.3
Processor Module – MB-700.....	1.3
Open Protocols.....	1.3
Configuration.....	1.3
Supervision	1.3
Chapter 2 - Installing.....	2.1
Fixing Racks and Modules	2.1
To install a Rack in the DIN rail	2.2
Adding Racks (Local I/O Expansion)	2.2
How to install a Module	2.2
TIPS for the Assembly.....	2.2
Installing the Hardware	2.3
Using the Fault Indication.....	2.4
Installing the System302	2.4
Getting the license for DFI OLE Server.....	2.4
Connecting the MB-700 to the Subnet.....	2.5
Chapter 3 - Configuring.....	3.1
Updating the Firmware	3.1
Setting the MB-700 through Software	3.6
Creating a New Plant.....	3.6
Chapter 4 - MB-700 Function Blocks.....	4.1
Block CCCF- Concentrate Configuration	4.1
Overview	4.1
Description	4.1
Direction of the data flow	4.1
MODBUS Addresses	4.2
Configuring the Serial Media	4.2
Configuring the TCP Media.....	4.3
Scan Cycle.....	4.3
Parameters	4.4
Block CCSM - Concentrate Supervision Master.....	4.6
Overview	4.6
Description.....	4.6
A) Configuring points to be supervised	4.6
B) Data Supervision.....	4.7
C) Supervision status.....	4.8
Parameters	4.8
Block CCCM- Concentrate Control Master	4.10
Overview	4.10
Schematic.....	4.10
Description.....	4.10
A) Functioning of a communication peer-to-peer in a MODBUS device.....	4.10
B) Addressing.....	4.11
C) Monitoring data.....	4.13
D) Supervision Status	4.13
Parameters	4.14

Block CCDL – Concentrate Data Logger	4.15
Overview	4.15
Description	4.15
Parameters	4.16
Chapter 5 - Adding MODBUS to the MB-700	5.1
MB-700 as Serial MODBUS Master.....	5.1
Scenario.....	5.1
Description.....	5.1
OFF LINE Configuration	5.2
On Line Configuration.....	5.11
MB-700 as a TCP/IP Master.....	5.11
Description.....	5.11
1 - MB-700 working as Bypass (Serial to TCP)	5.11
Configuration.....	5.12
2) MB-700 working as Peer-to-peer.....	5.14
MB-700 as a TCP/IP Modbus Slave	5.15
MB-700 working as Concentrator	5.15
Using the Data Logger	5.16
Description.....	5.16
Configuration.....	5.16
Putting CCDL blocks in cascade	5.18
Block Minimum Configuration Table for the MB-700	5.18
Chapter 6 - Scenarios.....	6.1
Multiple masters TCP/IP communicating directly with several LC700s, including via Radio	6.1
Multiple masters TCP/IP communicating directly with several LC700s and “peer-to-peer” between LC700s within a same Modbus RTU network.....	6.2
Multiple masters TCP/IP communicating directly with several LC700s and “peer-to-peer” between LC700’s of different Modbus RTU networks.....	6.3
Multiple masters TCP/IP communicating directly with LC700s , “peer-to-peer” and network redundancy	6.4
MB-700 as a concentrator and supervision via DFI OPC Server	6.5
MB-700 working as a concentrator and supervision via DFI OPC server and “peer-to-peer”.....	6.6
MB-700 as concentrator, supervision via DFI OPC Server, “Peer-to-peer” and network redundancy	6.7
Multiple MODBUS RTU masters accessing a LC700 through only one port (P2).....	6.8
Chapter 7 - Redundancy Hot Standby	7.1
Complete Redundant System Architecture	7.1
MB-700 Module Redundancy	7.2
Terminology	7.2
System Pre-requirements.....	7.2
Configuring the Network Redundancy	7.3
Configuring the workstation.....	7.3
Configuring the DFI OLE Server.....	7.3
Configuring Hot Standby Redundancy.....	7.4
First time configuration procedure	7.6
Changing Configuration	7.7
Replacing a module with failure.....	7.7
Correcting a failure in the Synchronism Channel.....	7.7
Firmware update without process interruption.....	7.7
Adding redundancy to an existing system.....	7.8
SYNC_CABLE Physical Connection.....	7.8
Additional Parameter Table.....	7.8
Description of meaning of RED_BAD_CONDITIONS_L / R bits	7.9
Appendix A - Troubleshooting	A.1
Reset	A.1
Factory Init.....	A.1
Modo HOLD.....	A.1
When to use the Factory Init/Reset procedure.....	A.2

Appendix B - Cabling B.1
Ethernet cable Specification B.1
Serial Cable Specification B.1
EIA-485 Interface B.2
Cable Specifications to connect the MB-700 to the LC700 B.2
Dimensions B.3

Appendix C - Technical Specifications C.1
Technical Specifications for the MB-700 module C.1
Data Types available for the parameter DATATYPE C.2
Scale Conversion C.3

GLOSSARY

Address of a MODBUS variable:

It refers to the address of the MODBUS variable read or written in a I/O block of a device.

Baud rate:

Data transference rate given in bits per second.

Bridge:

A bridge isolates two networks. It has the function of only passing the data addressed to it to the other side. It works in the data link layer.

Bypass:

When the MODBUS message is received by the MB-700 it is passed to the other network where it is connected.

CCCF:

Block that configures the communication between the MB-700 and slave devices.

CCCM:

Block that configures the peer-to-peer communication.

CCSM:

Block that configures the functioning of the concentrator function of the MB-700.

CCDL:

Block that sets the Data Logger.

Communication Protocols:

They are rules to control the data communication. Protocol is the software that controls and grants the communication, formats the way of sending data, defines the path, the sending and the reception of data, check for transmission errors.

Configuration:

Establishes the functioning parameters for the device.

Data Concentrator:

The MB-700 is a data concentrator because it stores variables read from MODBUS slave devices in its memory and makes them available to the supervision system and/or monitoring, avoiding these systems needing to access slaves of the network directly.

Download:

It means in the MB-700 context, to send configuration or firmware to a device.

EIA-232/EIA-485:

Establish the standards for cable (physical connection) to serial communication.

Ethernet:

IEEE 802.3 Standard. It refers to the physical mean where it is installed the local network. The baud rate may reach up to 10 Mbits/second.

Fast - Ethernet:

Operates at 100 Mbits/second and it is similar to the Ethernet. However, it is limited in 100 meters by the distance between HUB and workstation.

Function Blocks:

Device language programming of industrial automation. To each function block it is associated an algorithm and configuration parameters associated. The change of information between blocks will be done through links between inputs and outputs of the function blocks.

Gateway:

Protocol converters, they work in the layer 4 of the OSI model.

Hub:

It is a connection concentrator. Each element of the local network is connected to a HUB, isolating and helping error detection.

HSE:

High Speed Ethernet. Physical media of the protocol TCP/IP.

I/O:

It refers to the physical inputs and outputs of the logic controller where the data/information is sent to the process and read from it.

IP Address:

The IP protocol handles the data sending in a network. Each element has an IP address used to data communication. One IP address has 4 bytes. For example: 196.198.100.001.

Local Area Network (LAN):

It is the local network installed within a company, industry or institution, where these workstations exchange information from each other.

Logic Controller:

Logical controller devices are microprocessor devices that allow creating control logic for process automation.

Modem:

MODEM is a short for MODulator DEModulator. The device makes the FSK (Frequency Shift Keying), ASK (Amplitude Shift Keying) and PSK (Phase Shift Keying) modulation used to send digital data through telephone lines or via electromagnetic irradiation.

Modbus:

Communication protocol used for devices used in an industrial environment.

Modbus RTU:

This is the MODBUS communication standard that uses physical means like EIA-232, EIA-485 or radio. The main characteristic is supporting only one master.

Modbus/TCP:

MODBUS protocol that uses the TCP/IP layers supporting multi master mode.

Monitor/Monitoring

Visualize and change read variables.

Modbus Address:

MODBUS address within a MODBUS network.

Modbus Master:

Device that supports the MODBUS protocol handling the master role. This type of device has the ability to send commands to the MODBUS slave devices.

MODBUS slave:

Device that supports the MODBUS protocol playing the slave role. This type of device only answers to commands sent to it. It does not have the role of asking something from another device in the network.

Modbus Variable:

Variables from Modbus slave devices available through communication.

Networks:

It is a set of devices connected in order to change information with each other.

OSI Model:

ISO model that establishes a standard to the data transference phases in networks. There are seven levels in this model.

Level 7 - Application: Programs

Level 6 - Presentation: Data Conversion

Level 5 - Session: Establishing connection

Level 4 - Transport: Controls data transference

Level 3 - Network: Handles package sending, computing and transference of data

Level 2 - Data link Error management (detection and correction)

Level 1 - Physical: Specify the physical connection of network elements

Parameter:

Functioning, communication and storage characteristics of the MB-700.

“Peer-to-peer” Communication:

Communication way allowing changes of information between devices in the same hierarchic level. In applications using MB-700, peer-to-peer means change of information between devices.

Router:

Router is responsible for sending the data packages through an external network until they reach their destination. It works in the layer 3 of the OSI model.

Serial Communication:

Data is displayed in the serial format, a succession of pulses, a waveform that forms the data to be transmitted. Each bit is sent per time in one channel or way only.

Supervision System:

System located in the workstation where user may monitor and change field variable values and to control process.

Switch:

Similar to bridge but allows that several sub nets interact with each other.

TCP/IP:

Communication protocol in local networks and external corporate networks. It has 4 layers:

- Network Layer: Protocols of layers 2 and 3 of the OSI model.
- Router Layer: The IP protocol routes data in the networks, but cannot grant communication done properly.
- Transport layer: TCP and UDP protocols transmit data routed in the previous layer to the next layer.
- Application Layer: It is the equivalent to the layers 5,6 and 7 of the OSI model. In this layer are included ftp, SMTP, Telnet, etc.

Transmission media:

It is the physical media, where the port is sent.

Transmitter:

Device that includes both the electronic board and the transducer/sensor that sends the field variable read from this device.

REFERENCES

- Function Blocks Instruction Manual
- Syscon Manual
- LC700: User's Guide
- LC700: LC700 Configuration Manual

OVERVIEW

This manual presents instructions of how to install the MB-700.

The MB-700 is a microprocessor module. It has Ethernet, EIA-232/EIA-485 ports plus a synchronism port that might be used for redundancy. The MB-700 uses a power supply PS-AC-R. The MB-700 system consists of a CPU module plus this power supply module.

Hardware

- ✓ Backplane R-700-4 – Rack with 4 Slots.
- ✓ Processor Module MB-700 Processor 1x10 Mbps, 1xSYNC, Serial Ports EIA-232/EIA-485.
- ✓ Power Supply PS-AC-R.
- ✓ Cable Standard Ethernet DF54 – Twisted-Pair (10 base T) Cable – length 2 m.

Software

- ✓ DFI OLE Server (Used during configuration and when the MB-700 is set as a concentrator).
- ✓ System302.
- ✓ DHCP Server (optional).
- ✓ Windows NT workstation (Service Pack 3 or higher).

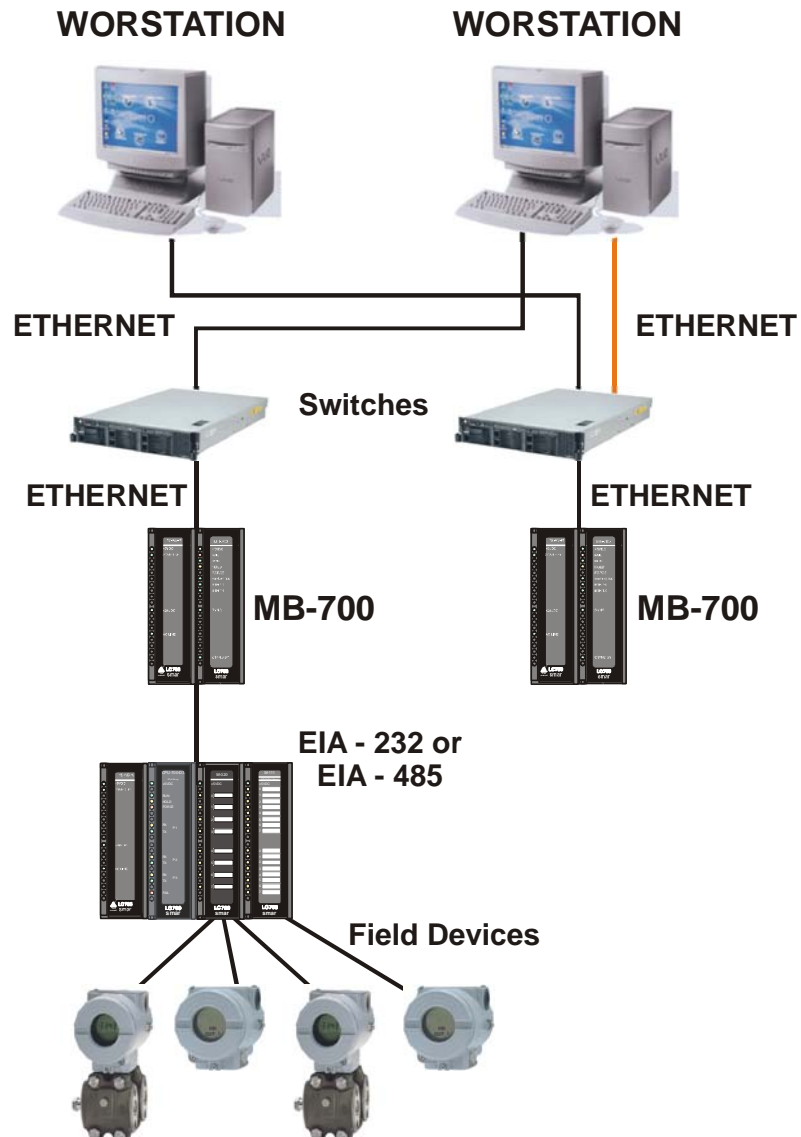

Main characteristics

MB-700 has a double function: it is both a bridge between Ethernet and Modbus networks and a data concentrator device.

The MB-700 has a modular concept and may be put in panels inside a control room or in sealed boxes in the field. It is indicated to remote applications avoiding that user needs to walk to the place where the process is located to configure the MODBUS device. User only needs to connect his workstation or Human Machine Interface (HMI) to the network and configures the logic controllers through the network. MB-700 handles the communication and conversion between protocols. It may be set to act as a data concentrator, collecting data from field devices connected to the MODBUS slaves. Its monitoring system or supervision system may access all this collected data directly on the MB-700 memory, instead of accessing these data directly from Field.

It is a multi function module mounted in a backplane connected in a DIN rail where it is also connected a PS-AC-R power supply module. Modularity is the key for flexibility of the MB-700.

Connections of source and SYNC channel (redundancy function) are done using plug-in connectors, making removing safe and easy. Connectors have an advantage, they cannot be connected in a wrong way, avoiding that high voltages are applied to a low voltage terminal. The power supply module has diagnostic LEDs to indicate normal operation or failure, what helps to solve troubles and to diagnose, especially in a system with several units. It is possible to remove the fuse (accessible externally located in the input) without the necessity to remove a source module or disconnect any wire.

It is important to notice:

- One Backplane is required for each 4 modules;
- One flat cable is required to connect Backplanes;
- MB-700 uses the DFI OLE Server. The license to the DFI OLE Server is available in different levels with different capacities for supervision of function blocks.

System Integration

Advanced communication characteristics built in the MB-700 grant the system high integration:

- Ethernet Port
- Modbus TCP/IP
- Serial EIA-232 / EIA-485 Ports
- Modbus RTU.
- Supports up to 31 slaves connected to the EIA-485 bus.

Power Supply – PS-AC-R

This module is the power supply for the MB-700 and LC700 system. It supplies 5V necessary to the IMB. This module has functions of diagnose and dedicated LEDs that indicate normal operation in failure conditions what makes possible troubles to be easily detected, especially in systems with several units. It is easy to check a power supply module with defects in a panel with several modules. It is possible to replace the fuse (located on the input with external access) without needing to remove the source module or disconnect any wire. The output is protected against short circuit and it is not damaged even in lasting short circuits.

Processor Module – MB-700

Based in a 32-bit RISC processor and firmware stored in a Flash memory, this module handles communication and control tasks.

- 1 Ethernet Port @ 10Mbps
- 1 SYNC Port @ 31,25Kbps
- 1 EIA-232/EIA-485 Port @ 9,6 Kbps – 115,2 Kbps
- CPU clock @ 25MHz, 2MB NVRAM

Open Protocols

Ethernet

Implements the Smart Ethernet protocols (SE) and MODBUS based on TCP/IP and may coexist with other Ethernet protocols.

Modbus RTU: EIA-232 and EIA-485

Using these ports, the MODBUS protocol connects data from a MODBUS network with your local area network. These ports may be connected to a device network (EIA-485) or connected to controllers through a modem or a radio link. Supports up to 31 slaves connected in each serial port using the EIA-485 standard.

Configuration

MB-700 is completely configured using the configuration tool (for example, SYSCON) through function blocks available in the Fieldbus Foundation Standard.

Supervision

The use of these technologies like OPC (OLE for Process Control) makes the MB-700 a flexible TCP-IP/MODBUS interface. The OPC Server allows the MB-700 to be connected to any supervision package. The only requirement is that there is an OPC client to the package, so user can connect the MB-700 with the best supervision interfaces available.

Chapter 2

INSTALLING

ATTENTION: If any of the steps are not followed, it may cause a malfunctioning of the system.

Fixing Racks and Modules

Note the figures of Module and Rack and proceed according instructions:

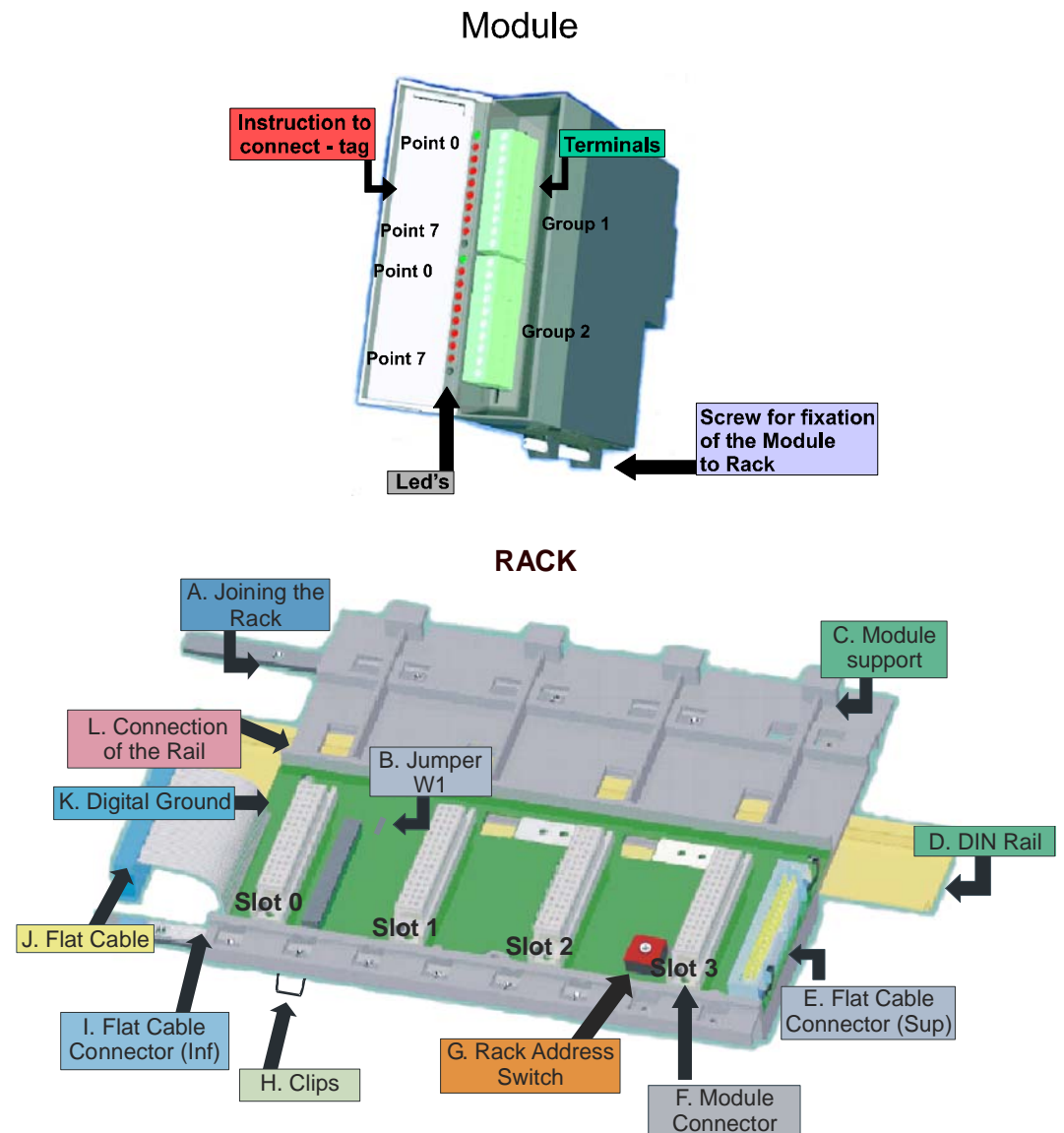

- A. Joining the Rack - when assembling more than one rack in a same DIN rail, use the special metallic piece to link one rack to the other. This connection generates stability to the assembly and makes possible the digital ground connection (k);
- B. Jumper W1 – when connected, it allows that rack to be powered by the previous rack;
- C. Module support;
- D. DIN Rail;
- E. Flat Cable Connector – When there are more than one rack in the same DIN rail, they must be hooked up by a flat cable (j) connected to the Flat Cable connectors (i) and (e);
- F. Module Connector;
- G. Rack Address Switch;
- H. Clips - Used to fix rack in the DIN rail;

- I. Flat Cable Connector (Inferior)– When existing more than one rack in the same DIN rail, they must be hooked up by a flat cable (j) connected to the Flat Cable connectors (i) and (e);
- J. Flat Cable;
- K. Digital Ground – When there are more than one rack in the same DIN rail, the connection between digital grounds (k) must be reinforced through appropriate metallic piece;
- L. Connection of the Rail.

To install a Rack in the DIN rail

- Locate the Clips on the bottom of the Rack;
- Use a screw-driver (or your fingers) to pull them down;
- Place the back of the Rack on the top of the DIN rail edge;
- Accommodate the Rack on the DIN rail and push the clips up. The user will hear a click sound when they lock properly;
- Set the correct address for the Rack using the rotating switch at the Rack.

Note
The addresses can NOT be repeated.

Adding Racks (Local I/O Expansion)

Local I/O Expansion is the process of adding more Racks connecting them through the Rack. A flat cable is used for this purpose. Different sizes are available to reach different situations.

- Connect the new Rack with the previous one by using a selected flat-cable;
- Don’t forget to place a terminator in the last Rack;
- Set the address for the new Rack using the rotating switch.

How to install a Module

- Locate the tab on the top of a free Slot in the Rack;
- Mount the Module by inserting the tab in the “square hole” on the back top of the Module box. Use is as a rotating latch!
- Latch the Module on to the connector (slot) on the Rack by pressing it.
- Use a screwdriver to tie the Module in the rack with the locking screw located at bottom os the Module box.

TIPS for the Assembly

In case if there was more than a rack in the same module:

- Do the fixation in the DIN rail at the end of the assembly;
- Keep the slot 3 free in the rack, to be able to establish connection to the next module for the connector of flat cable;
- Verify intently the address configuration (addressing key), as well as the Jumper W1 and the BUS cable;
- Remember that to give continuity to DC power supply of previous rack it is necessary that jumper W1 would be connected;
- Make the amendment of racks and strengthens the digital ground of the hardware.

Installing the Hardware

See the details of the frontal view of the modules:

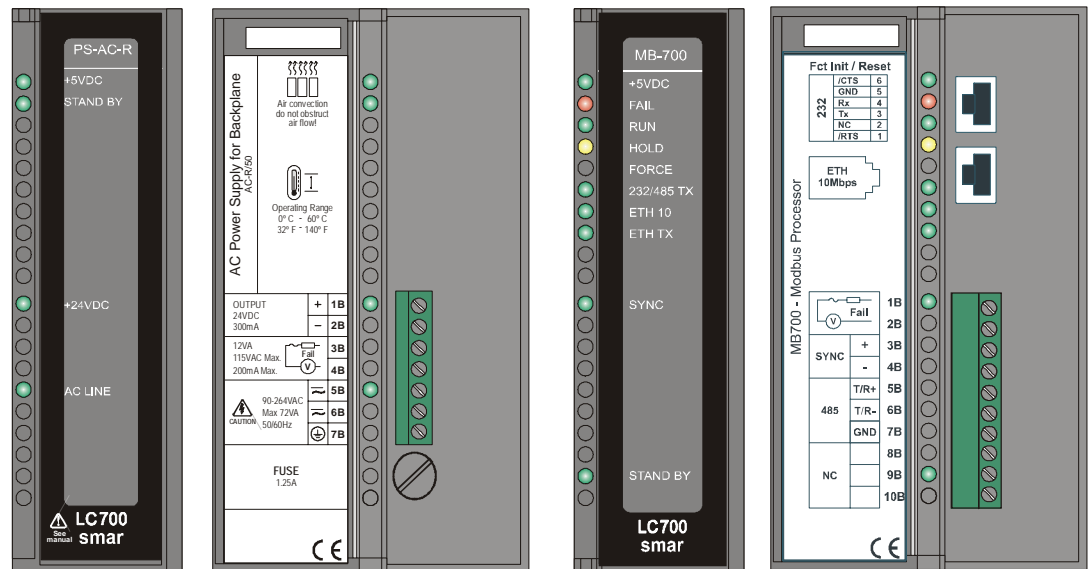

PS-AC-R (Power Supply) and MB-700

Straight twisted-pair cable is used for wiring the MB-700s and hubs together. The MB-700s have simple RJ-45 connectors. No special tools or skills are therefore required. Installation is simple and very fast. LED's indicate active communication or failure.

The user must connect and disconnect without having to power down. The hub/switched based star topology mean that devices can disconnect without disrupting control or communication of other nodes.

The two types of existing cables enable the connection MB-700/hub (DF54 cable) or direct connection MB-700/PC (DF55 cable). See the Appendixes for further details.

Basic installation tips:

1. Connect the two modules (PS-AC-R and MB-700);
2. Connect the AC line in the input of the PS-AC-R;
3. Plug the Ethernet cable (straight pair cable) connecting MB-700 to the HUB/Switch.
4. The MB-700 will automatically get an IP address from the DHCP server, but if this server is not available, it will initially have a fixed IP address (this fixed IP may be changed through the FBTools-see topic "Connecting the MB-700 to the Sub-net").

Using the Fault Indication

The 1B and 2B Terminals available in the **MB-700**, may be used in a Fault Indication application. Actually, these terminals are only a NC Relay.

The NC Relay supports:

0.5A @ 125VAC
0.25A @ 250VAC
2A @ 30VDC

Normally, **MB-700** forces this relay to remain opened but if any bad condition crashes the Processor, the hardware will close the relay. This status may be used in redundancy situation, where the backup Processor reads this contact and knows about the fault. Other possibility is using this contact to turn on an alarm.

Installing the System302

Install the software from the CD of System302. All applications included in the System302 can be accessed by the shortcut “System302 Browser”.

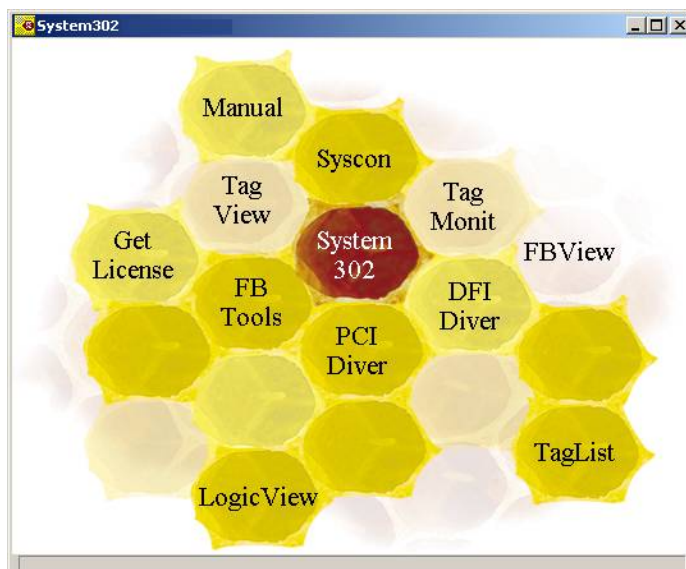

Getting the license for DFI OLE Server

There are two ways to get a license to use the DFI OLE Server. There is the Hard Lock protection version (Hard key) and the software version (SoftKey).

The Hard key is already ready for use, it is only necessary to connect the device in the parallel port of your PC.

In order to use protection through software it is required to get a License key getting in touch with SMAR. Use the application tool Getlicense.exe located on the Smar’s working directory (usually “drive:\Program Files\Smars\OLEServers\Getlicense.exe”), or directly through the shortcut “Get License” in the SMAR directory/Browser (see previous picture).

From the information created in this application fill the form FaxBack.txt and send it to Smar to get license to use the SYSCON and/or DFI OLE Server.

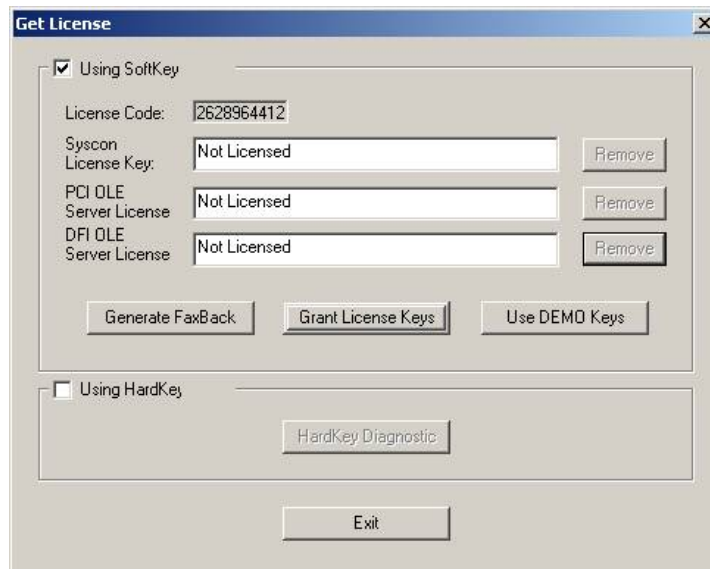

When the user receives a reply from Smar with the License Keys, type the codes in the blank fields (see figure above). Press the “Grant License Keys” button. In case the codes are accepted, success confirmation messages will be displayed. The DFI OLE Server and SYSCON are ready for use.

Connecting the MB-700 to the Subnet

The environment with MB-700 involves a network (Sub net) where it is necessary the IP address for each connected device.

The solution for this attribution is a DHCP (***Dynamic Host Configuration Protocol SERVER***) server. It will handle the IP attribution dynamically to each device, avoiding any troubles like equal IP addresses to two different devices.

ATTENTION

To connect more than one **MB-700**, the following steps must be completely executed to each MB-700

1. Connect the Ethernet cable DF54 of the MB-700 module to the Switch (or HUB) of the sub net where the MB-700 will be put.
OBS- For point to point connections (the MB-700 connected directly to the PC) use the crossed cable DF55.
2. Turn the MB-700 modules on. Be sure that the ETH10 LED and the Run LED are on.
3. Keep the PUSH BUTTON on the left pressed tightly (Factory Init/Reset) and next click at the PUSH BUTTON of the right three times, certifying that the FORCE LED blinks three times per second.

NOTE: if the counting of how many times the PUSH BUTTON at right was pressed was lost, check the number of times the FORCE LED blinks per second. It will blink again once per second after the fourth touch (in another words this function is cyclic).

4. Release the left push-button and the system will execute the RESET and subsequently will execute the firmware with the standards values for IP address and the Sub-Net Mask.

5. If your network has a DHCP server (consult the administrator of your network) the MB-700 is already connected to your Sub-Net. Otherwise it will have an IP address 192.168.164.100 and the user will have to execute the next steps:

6. If the user is following this step your network does not have a DHCP server. Thus it will temporarily change the IP address of your Workstation (it is recommendable to have network management knowledge). Enter the Control Panel (Windows Control Panel and choose the option Network.

NOTE: In case the Network option in your control panel does not have the TCP/IP protocol, use the Windows to proceed with the installation.

7. Choose the Internet Protocol option (see figure below) and click at the Properties button.

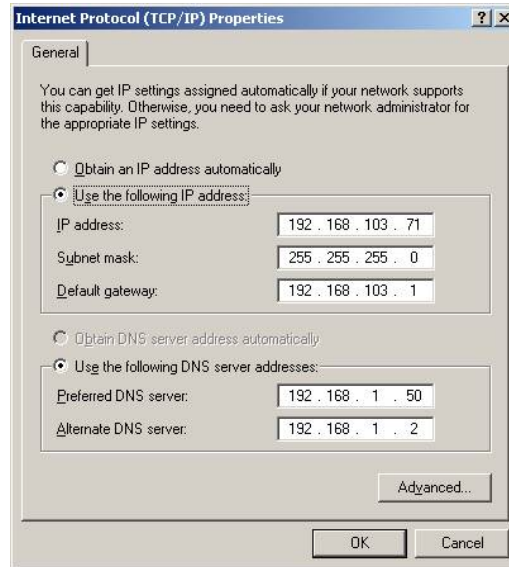

8. Write down the original IP address and the sub net mask of the workstation so the user will be able to restore them at the end of this operation.

9. Change the IP address and the sub net mask of your PC so it is located in the same Sub net of the MB-700. Preferable the IP addresses used must be supplied by the Network administrator.

Note

Values must be of the type: IP Address 192.168.164.XXX and subnet mask 255.255.255.0. Keep the value for Default Gateway.

ATTENTION

Do not use the address 192.168.164.100 once it is the default address used by the MB-700.

10. Click at the OK button.

11. Run the FBToolsWizard.exe (located in the working directory of Smar) directly from the shortcut “FBTools Wizard”, or directly using the shortcut “FBTools Wizard”.

12. Select the **MB-700** device and press NEXT.

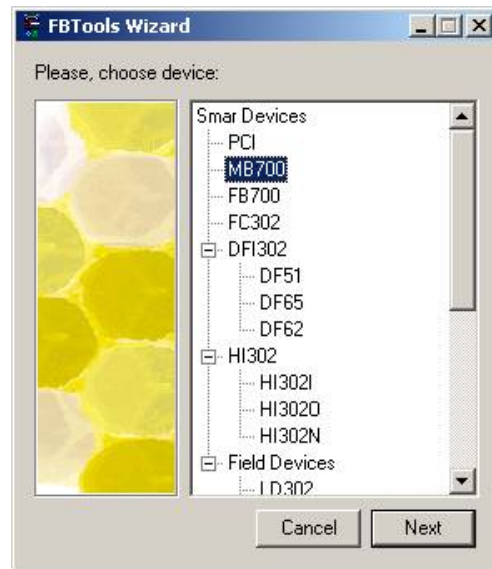

13. The following window will be showed, click at *Connect* in order to visualize the available modules.

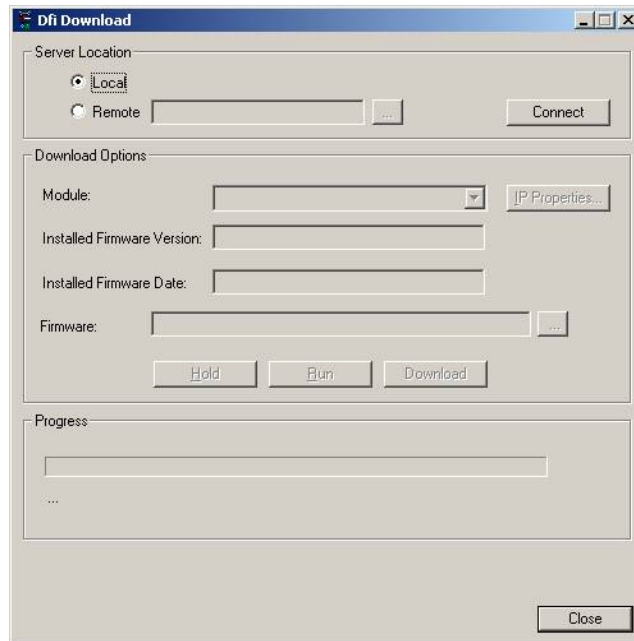

14. Select the target **MB-700** module in the option *Module* using as reference the serial number (see the external identification label of the MB-700).

ATTENTION

If the user does not follow this step this might imply in serious consequences.

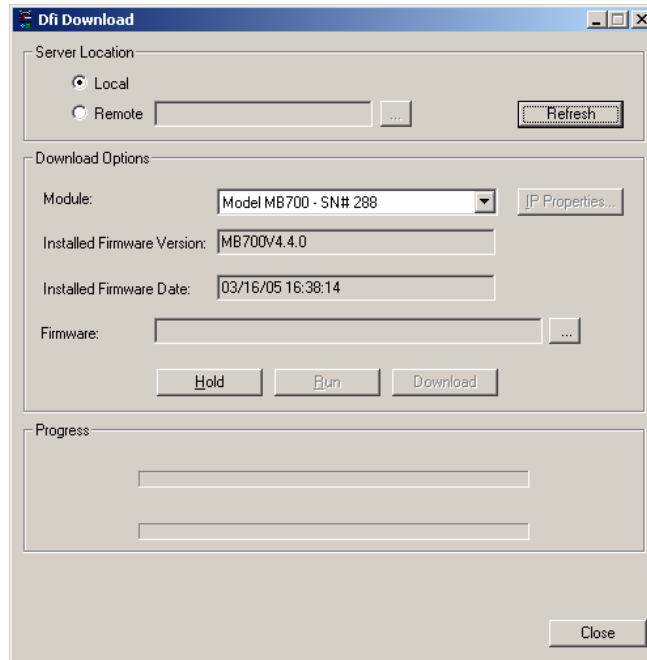

15. To go ahead it is necessary to stop the firmware running the **MB-700** Processor. Press the **HOLD** button.

16. After the user is done with the previous step, the module will not running the firmware so it will stop all its activity. Confirm the operation,

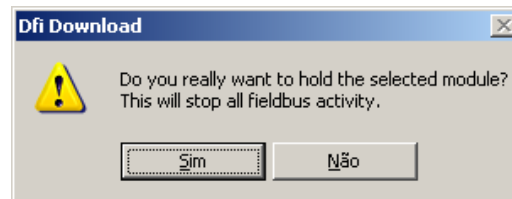

17. Be sure the **HOLD** led is ON. After stopping the firmware execution in the module, the window will appear again.

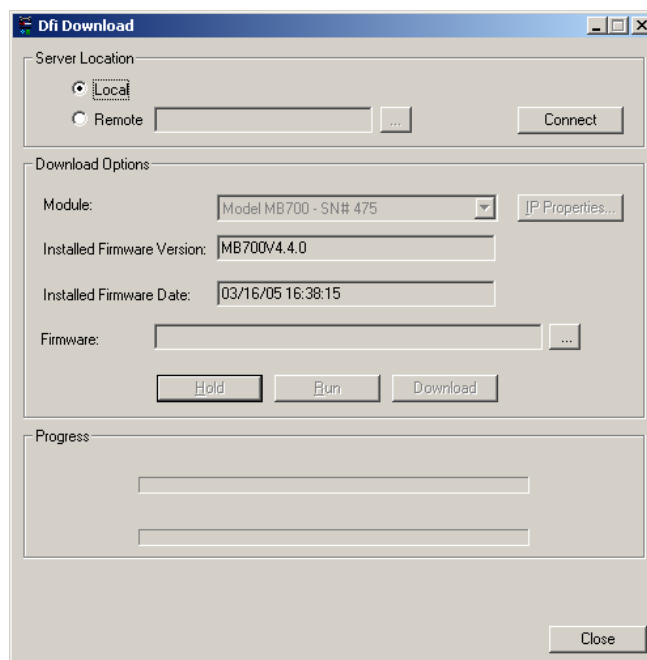

18. Select the target MB-700 in the option "Module" using as reference the serial number of the MB-700.

ATTENTION

If the user does not follow this step this might imply in serious consequences.

19. The default option is attribution through *DHCP Server*. Click at the IP Properties option. The picture below will be showed.

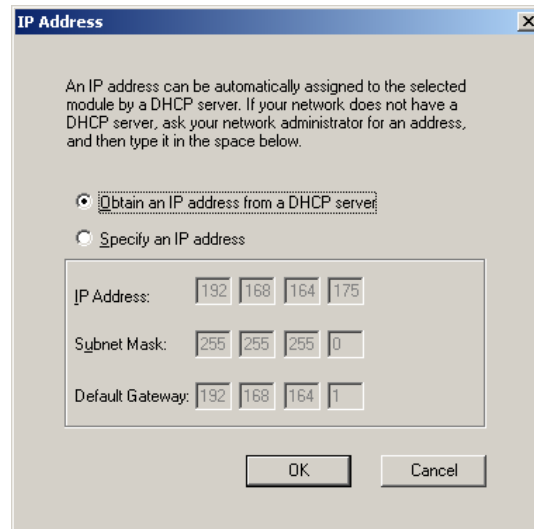

20. Click at the Specify an IP address option. Type the IP address and subnet mask to be attributed to the **MB-700**.

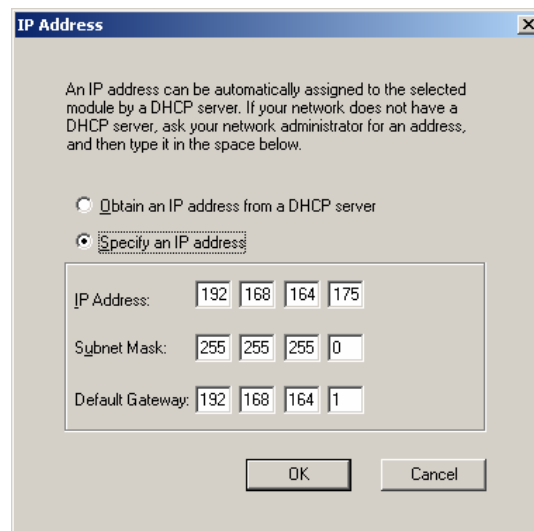

ATTENTION

Do not use the IP 192.168.164.100 once it is the default address used by the MB-700. Be certain this address is not being used.

TIP

Take note of the IP address attributed and relate them to the serial numbers of each module. This will help during identification and diagnose of the possible failures.

21. Press *OK* to end this operation.

22. Now return to the screen TCP/IP properties of the PC and restore the original values of IP address and subnet mask.

23. After giving the **MB-700** a new IP, the process will be back to the Dfi Download screen. Hit the next button to go to the next screen and to put the firmware running again.

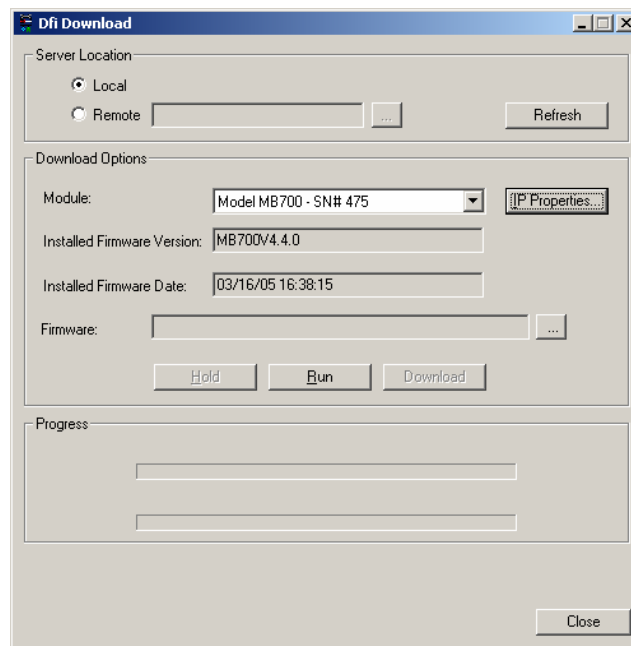

24. Hit *Run* to put the Firmware again running in the **MB-700**;

25. Hit Cancel in the screen Choose Server to finish the operation of IP attribution.

26. In the DOS prompt type `C:\>arp -d 192.168.164.100 <enter>` (see note below).

27. End of connection procedure of the MB-700 in the subnet.

NOTE

In case it is necessary to set more than one MB-700 run the following command to clear the ARP table, before passing to the next MB-700 configuration: `C:\>arp -d 192.168.164.100 <enter>`

CONFIGURING

Updating the Firmware

1. Connect the Ethernet cable DF54 of the **MB-700** module to the Switch (or HUB) of the sub net where the **MB-700** will be put.

OBS- For point to point connections (the MB-700 connected directly to the PC) use the cross cable DF55.

2. Turn the **MB-700** modules on. Be sure that the ETH10 LED and the Run LED are on.

3. Keep the PUSH BUTTON on the left pressed tightly (Factory Init/Reset) and next click at the PUSH BUTTON of the right three times, certifying that the FORCE LED blinks three times per second.

NOTE: if the counting of how many times the PUSH BUTTON at right was pressed was lost, check the number of times the FORCE LED blinks per second. It will blink again once per second after the fourth touch (in another words this function is cyclic).

4. Release the left push-button and the system will execute the RESET and subsequently will execute the firmware with the standards values for IP address and the Sub-Net Mask

5. If your network has a DHCP server (consult the administrator of your network) the MB-700 is already connected to your Sub-Net. Otherwise it will have an IP address 192.168.164.100 and the user will have to execute the next steps:

6. If the user is following this step your network does not have a DHCP server. Thus it will temporarily change the IP address of your Workstation (it is recommendable to have network management knowledge). Enter the Control Panel (Windows Control Panel and choose the option Network.

NOTE: In case the Network option in your control panel does not have the TCP/IP protocol, use the Windows to proceed with the installation.

7. Choose the Internet Protocol option (see figure below) and click at the Properties button.

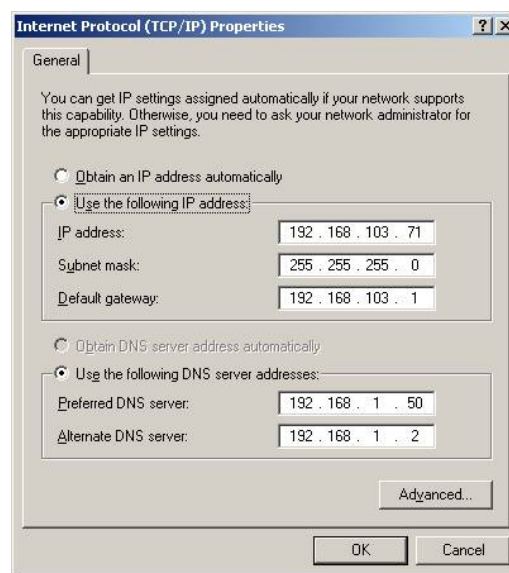

8. Write down the original IP address and the sub net mask of the workstation so the user will be able to restore them at the end of this operation.

9. Change the IP address and the sub net mask of your PC so it is located in the same Sub net of the MB-700. Preferable the IP addresses used must be supplied by the Network administrator.

Note

Values must be of the type: IP Address 192.168.164.XXX and subnet mask 255.255.255.0. Keep the value for Default Gateway.

ATTENTION

Do not use the address 192.168.164.100 once it is the default address used by the MB-700.

10. Click at the OK button.

11. Run the FBToolsWizard.exe (located in the working directory of Smar) directly from the shortcut “FBTools Wizard”, or directly using the shortcut “FBTools Wizard”.

12. Select the **MB-700** device and press NEXT.

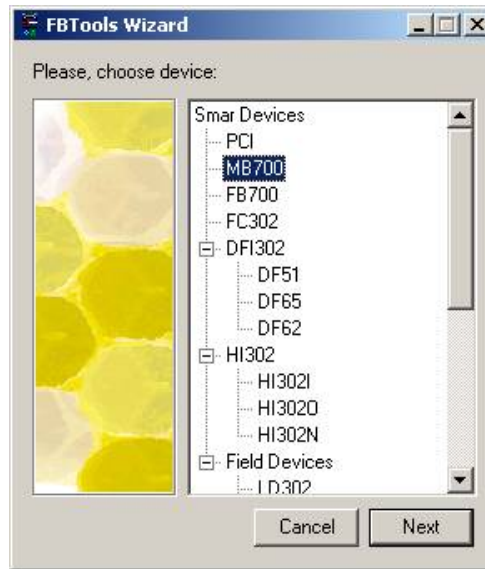

13. The following window will be showed, click at *Connect* in order to visualize the available modules.

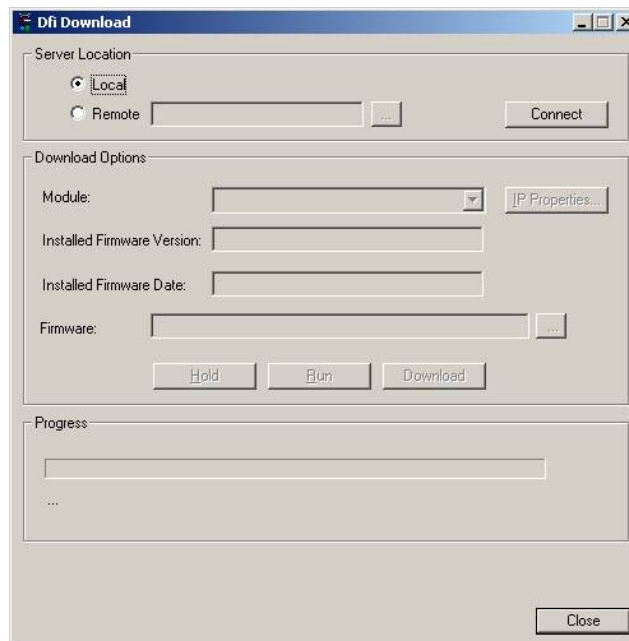

14. Select the target **MB-700** module in the option *Module* using as reference the serial number (see the external identification label of the MB-700).

ATTENTION

If the user does not follow this step this might imply in serious consequences.

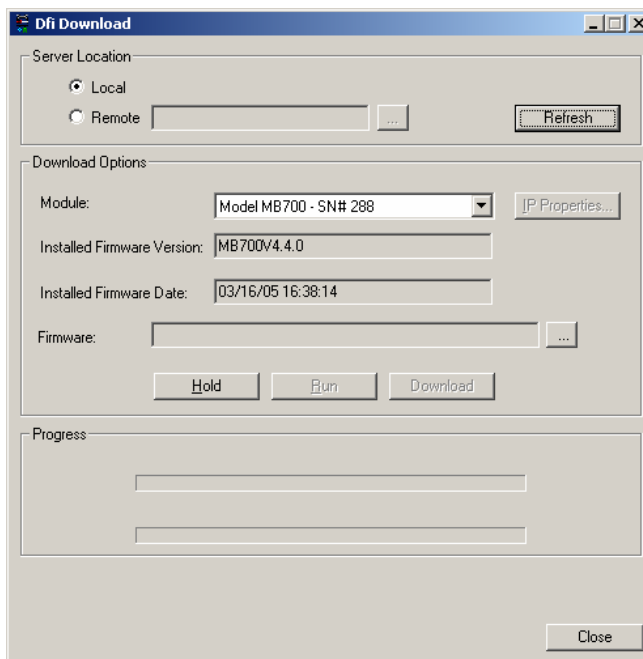

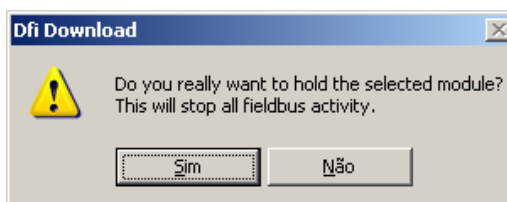

15. To go ahead it is necessary to stop the firmware running the **MB-700** Processor. Press the *HOLD* button.

16. After the user is done with the previous step, the module will not running the firmware so it will stop all its activity. Confirm the operation,

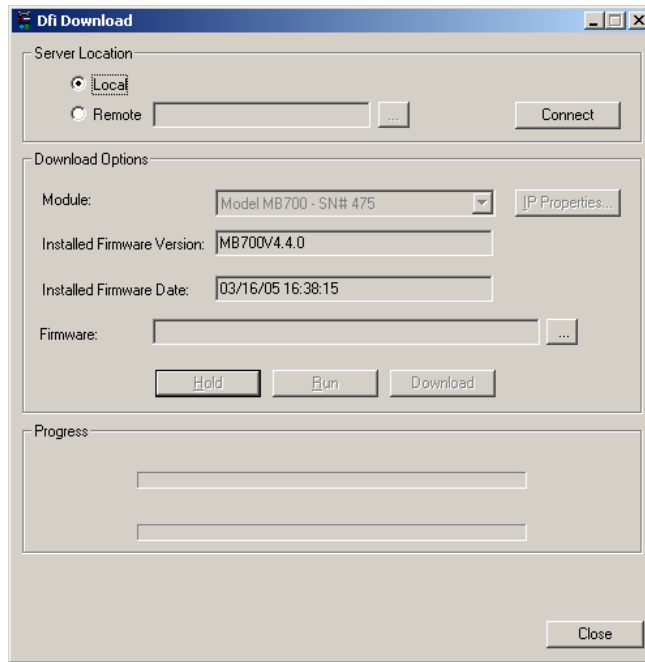

17. Be sure the HOLD led is ON. After stopping the firmware execution in the module, the window will appear again.



18. Click at the button  and choose the desired firmware to download. After choosing the firmware, the following window will open:

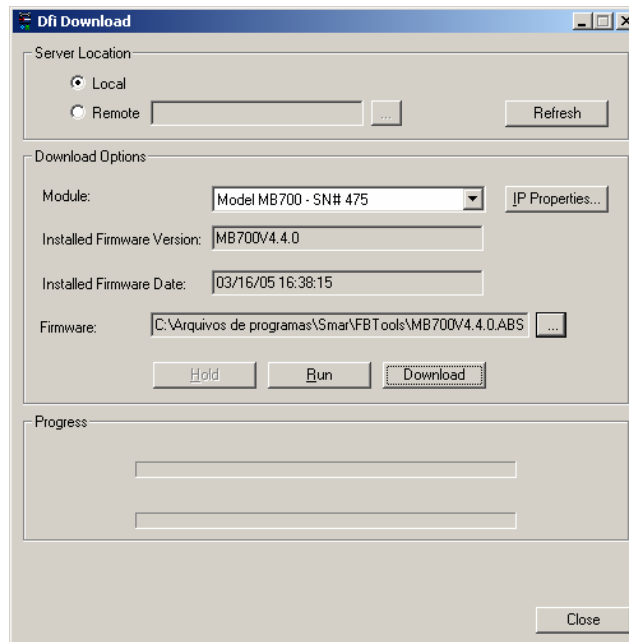

Attention

If this step is not observed, it might imply in serious consequences.

19. Click at the *Download* button. The following dialog box will be showed:

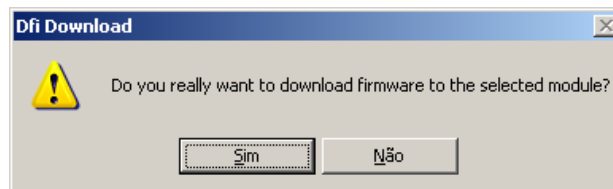

20. If the option *Yes (Sim)* is chosen, then the firmware download will be started.
21. During the download, the progress indication screen of the operation is displayed.

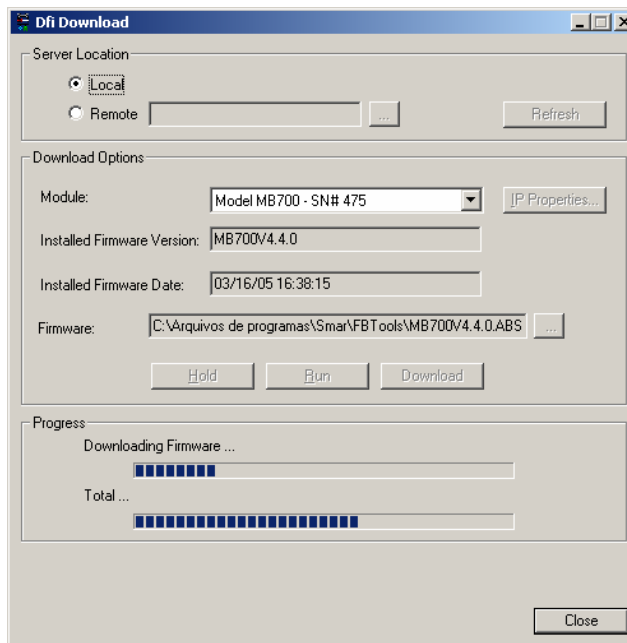

22. At the end of the operation, a status message of the download will be displayed. At this moment, the **MB-700** will be on *Run* mode. Click at the *OK* button. (Be sure the RUN LED is lit).

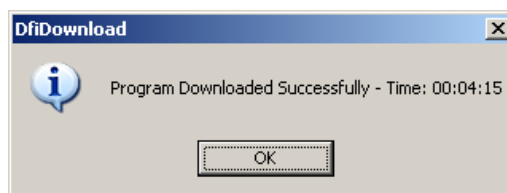

23. To finish this operation, click at the *Close* button.

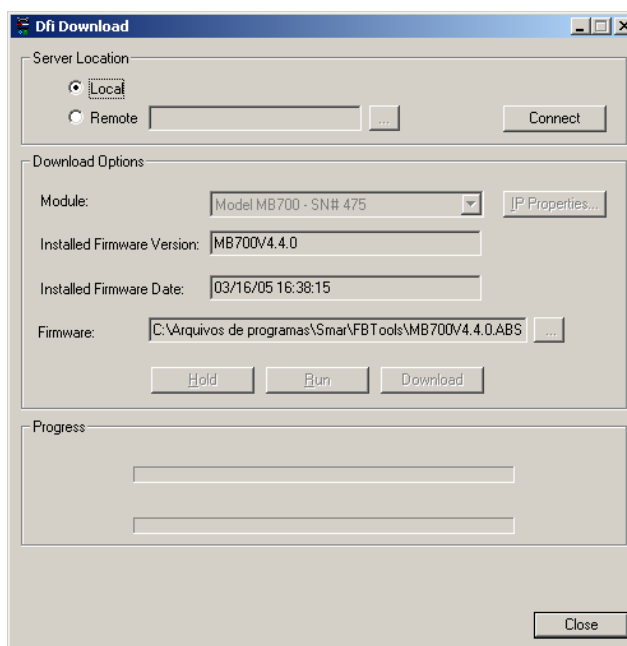

Setting the MB-700 through Software

ATTENTION

In order to have the MB-700 properly set by SYSCON it must be assured the procedure “Connecting the MB-700 to the Subnet” was done properly.

The MB-700 is totally set through Function Blocks available in the Fieldbus Foundation standard.

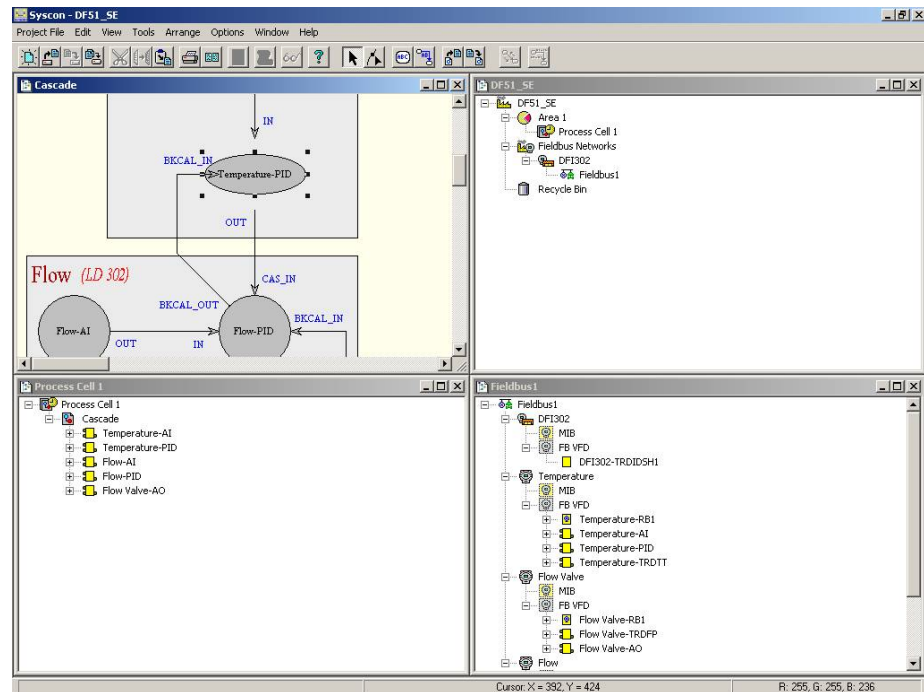

The MB-700 works together with the SYSCON, configuration and maintenance software, to use the plug and play characteristic allowing to detect, identify and attribute addresses to devices connected, removed or that have trouble. Once it is connected to the Ethernet bus or to a Workstation, the MB-700 is detected and next it is attributed a fixed IP address or variable depending on the process set via FBTools, eliminating any troubles with the dip switches or address duplication.

Creating a New Plant

Certify to have installed the System302 package that contains the Syscon.

1. Once it is installed the Syscon, run the application.



2. In the main window, choose *Project File* → *New*.

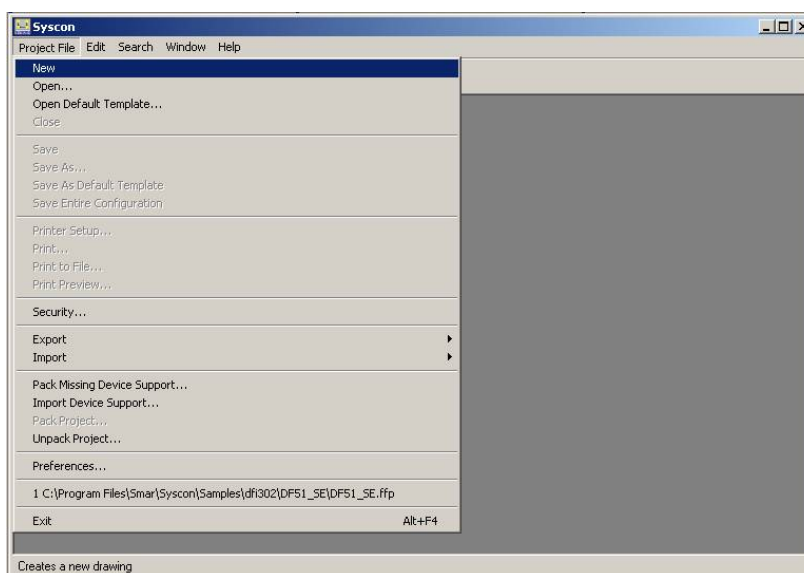

3. Choose *Projects* and give a new name to the new plant.
4. Initially, it must configure to use the *DFI OLE Server*.
5. In the project toolbar, click at *Fieldbus Networks* in order to configure the server. In the main window, choose *Communication* → *Settings*.

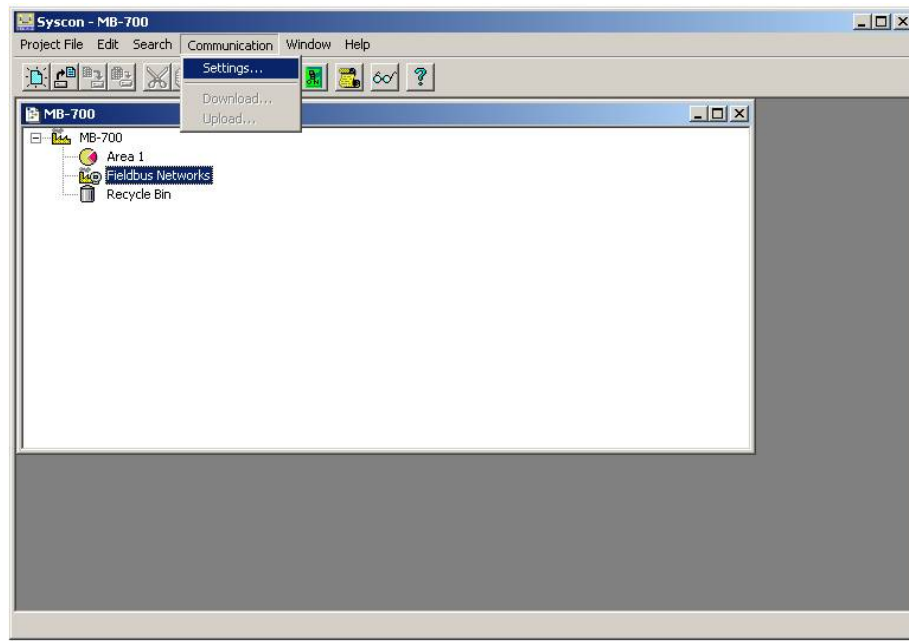

6. Select the name Smar.DFIOLEServer0. in the parameter Server ID and press OK.



7. Add a Fieldbus channel required
8. In the MB-700 device, add the CCCF (Configuration) and Resource blocks.
9. Do the Off Line configuration of the device.
10. According to the process, add CCSM or CCCM blocks. See chapter 4 "Adding Function Blocks to the MB-700". For further details, see the Syscon manual.

MB-700 FUNCTION BLOCKS

Block CCCF- Concentrate Configuration

Overview

This block allows the configuration of several communication parameters of the Modbus protocol.

Description

This block allows setting parameters of the communication between MB-700 and Modbus slave devices through Ethernet and serial (EIA-232/EIA-485) ports. User defines the baud rate for serial ports, parity, timeout, number of retransmissions and bypass direction.

IMPORTANT

User must set ONLY one CCCF block for each device.

Direction of the data flow

User must also set the parameter BYPASS_DIRECTION in order to establish the direction of the bypass. There are two options:

- ✓ 0: TCP to serial (default)
- ✓ 1: Serial to TCP

In the pictures below, two bypass scenarios using MB-700 are showed:

- **TCP/IP to Serial:** MB-700 works as Modbus TCP gateway for Modbus RTU. When a MODBUS command reaches the MB-700 via TCP/IP and the command addresses a different device of the one set in the parameter DEVICE_ADDRESS, this command is transmitted in the serial ports (EIA-232/EIA-485). If there is an answer from the addressed device this answer is sent in the TCP/IP port.

Application: Master MODBUS TCP/IP communicating with MODBUS RTU typical slave devices for supervision, configuration; or MB-700 working as data concentrator or peer-to-peer.

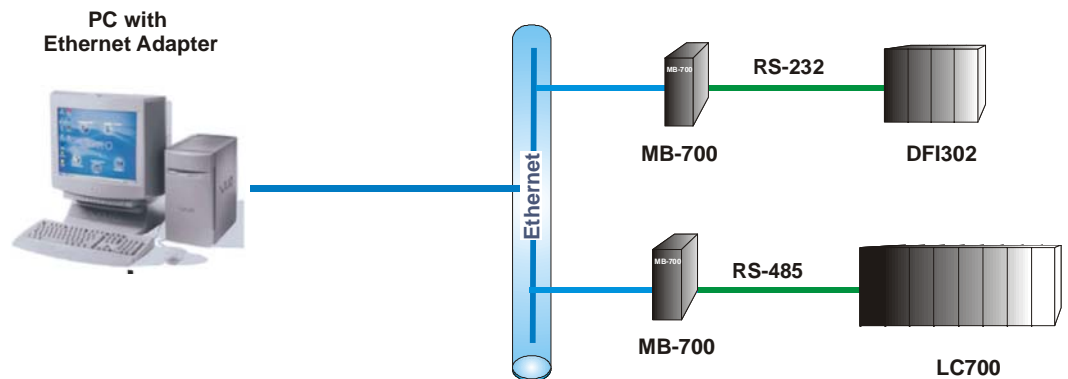

- **Serial to TCP/IP:** Selecting this option the MB-700 will work as a serial slave device (EIA-232 or EIA485) and as TCP/IP master. One MODBUS RTU command that reaches the MB-700 via serial (EIA-232/EIA485) will be sent in the TCP/IP port. If there is an answer in the TCP/IP, the answer is sent in the serial ports.

Application: MODBUS RTU master device communicating with a typical Modbus TCP/IP slave.

Working together with other MB-700 allows that several MODBUS RTU master devices communicate with the same slave device through only one port. In other words, it converts the MODBUS RTU protocol in multi master.

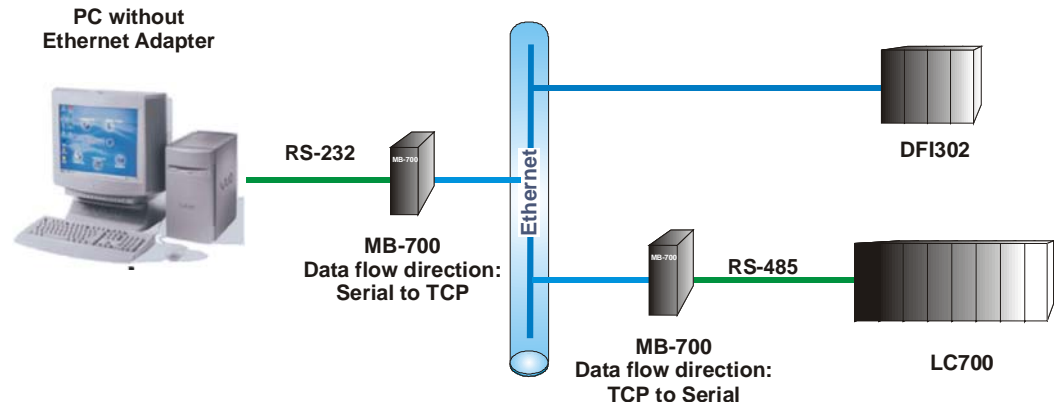

MODBUS Addresses

User must attribute a Modbus address to the MB-700. However this address must be unique in the Modbus networks where the MB-700 is connected through Ethernet or serial ports. In this case, user must set the DEVICE_ADDRESS parameter. The default value for this parameter is 247.

Configuring the Serial Media

In applications where the serial port of MB-700 is used, user must set the following parameters:

1 - Rate of transference of the serial ports

It is possible to select the baud rate of data in the serial ports. They may be set through the parameter BAUD_RATE. It allows the selection among the following baud rates:

- ✓ 0: 100 bps
- ✓ 1: 300 bps
- ✓ 2: 600 bps
- ✓ 3: 1200 bps
- ✓ 4: 2400 bps
- ✓ 5: 4800 bps
- ✓ 6: 9600 bps(default)
- ✓ 7: 19200 bps
- ✓ 8: 38400 bps
- ✓ 9: 57600 bps
- ✓ 10: 115200 bps

2 - Parity

Parameter PARITY defines the type of parity to the serial ports.

- ✓ 0: No parity
- ✓ 1: Even Parity (default)
- ✓ 2: Odd parity

3 – Timeout and Number of retransmissions

Timeout: time waited for an answer from a slave, after a message has been sent through one of the serial (P1 or P2) or Ethernet ports. The TIME_OUT parameter can change between 0 and 65535 milliseconds, and its default value is 1000. This parameter is directly connected to the NUMBER_RETRANSMISSIONS parameter.

Number of retransmissions: number of times the MB-700 will retry to establish communication with the slave device after not getting a reply. The time waited for this answer is set by the TIME_OUT parameter. The number of retransmissions is chosen through the NUMBER_RETRANSMISSIONS parameter. User may select a value in the range 0 to 255 to this parameter, and its default value is 1.

For the Bypass function, the NUMBER_RETRANSMISSIONS parameter is not applied.

4 – RTS/CTS

For devices that require RTS and CTS signals, user can enable or disable this option. In the RTS_CTS_TIMEOUT parameter, user sets the maximum time for waiting the CTS after the RTS has been sent. If the RTS_CTS_TIMEOUT parameter is equal to 0, this function will be disabled. The default value is 0 (disabled).

5 –Time delay between Rx and Tx

Optionally, an extra time between the end of receiving (Rx) and the beginning of the next serial transmission (Tx) can be set. The TIME_DELAY parameter defines the time, in milliseconds, of the delay time. This delay time is used when the device (master or slave) has slowness in the serial processing.

If MB-700 acts as Serial Master, the delay will be between a slave answer and the next MB-700 request.

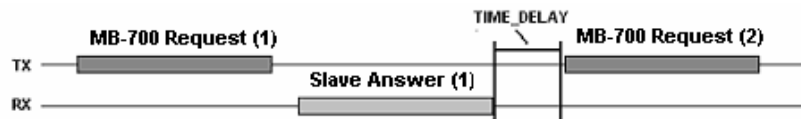

If MB-700 acts as Slave Serial, the delay will be between the Master request and MB-700 answer for the Master.

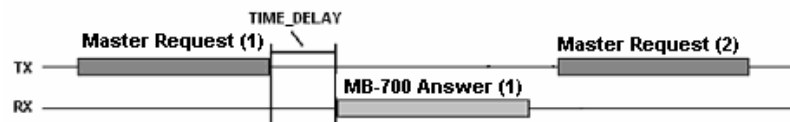

Configuring the TCP Media

For the applications where MB-700 is used as Modbus TCP Master, the following parameters must be configured:

- If there is a TCP slave with a unique Modbus address, the SLAVE_ADDRESSES parameter must be used, which the IP address of the Slave is configured (IP_SLAVE_1 to IP_SLAVE_6) and the respective Modbus Address of the Slave (MODBUS_ADDRESS_SLAVE_1 to MODBUS_ADDRESS_SLAVE_6);
- If there are many Modbus Slaves for the same IP address, the IP_SLAVE_x parameters with the respective Modbus addresses of the slaves DEVICE_IDS_IP_x must be used (where x means the parameters 7 to 12).

For further details about this configuration type, refer to the Chapter 5 “Adding blocks to the MB-700”.

Scan Cycle

The scan cycle of supervision blocks and control may be set through the parameters SUPERVISION_OFF_DUTY and CONTROL_OFF_DUTY. Parameter SUPERVISION_OFF_DUTY indicates time in milliseconds of the delay (between readings) during the supervision scan (block CCSM). In the same way, parameter CONTROL_OFF_DUTY indicates the delay during scan of control (CCCM).

Note

When MB-700 acts as bypass or there are written commands for Supervision, these commands has priority over the supervision and control scan and they don't follow the OFF_DUTY times.

Parameters

Idx	Parameter	Data Size (length)	Valid Range/Options	Default Value	Unit	Store / Mode	Description
1	ST_REV	Unsigned16		0	None	S	
2	TAG_DESC	OctString(32)		Spaces	Na	S	
3	STRATEGY	Unsigned16		0	None	S	
4	ALERT_KEY	Unsigned8	1 to 255	0	None	S	
5	MODE_BLK	DS-69		O/S	Na	S	See Mode Parameter
6	BLOCK_ERR	Bitstring(2)			E	D / RO	
7	REDUNDANCY_ROLE	Unsigned8	Not used	Main	E	S / O/S	It specifies the preferable MB-700 to be Active, when there is redundancy.
8	REDUNDANCY_STATE	Unsigned8	Not used	Standby	E	D/RO	It shows which MB-700 is Active and which MB-700 is in Standby mode.
9	BAD_COMM	Boolean	Not used	TRUE	E	D / RO	It indicates if any slave Modbus device scanned by MB-700 is not communicating.
10	BAD_COMM_STANDBY	Unsigned8	Not used	TRUE	E	D / RO	It indicates if the Standby is not able to communicate with a slave device.
11	CHECK_COMM_STANDBY	Unsigned8	0-255	0	Na	S/RW	This parameter is configured to Standby, if the communication test between the slave equipment was performed in TCP. 0: Disables the test. 1 – 255: Enables the test and defines the time interval, in seconds, between each test.
12	DEVICE_ADDRESS	Unsigned8	1-247	247	E	S / O/S	Define the device address in the Modbus network when acting as a slave.
13	SLAVE_ADDRESSES	DS-263				S / O/S	IP number and corresponding device address of slave device, when accessed through Ethernet TCP/IP.
14	BAUD_RATE	Unsigned8	0:110, 1:300, 2:600, 3:1200, 4:2400, 5:4800, 6:9600, 7:19200, 8:38400, 9:57600, 10:115200	9600	E	S / O/S	It defines the baud rate for serial ports.
15	STOP_BITS	Unsigned8	0:1, 1:2	1	E	S / O/S	It defines the number of stop bits for serial ports.
16	PARITY	Unsigned8	0:None, 1:Even, 2:Odd.	Even	E	S / O/S	It defines the parity for serial ports.
17	TIMEOUT	Unsigned16	0-65535	1000	ms	S / O/S	Time to wait a response from a slave after sending the command in the serial ports.
18	RTS_CTS_TIMEOUT	Unsigned16	0-65535	0	ms	S / O/S	Specify the maximum time waiting for RTS become active after setting RTS in the serial ports.
19	NUMBER_RETRANSMISSIONS	Unsigned8	0-255	1		S / O/S	Number of retransmission if MB-700 doesn't receive response from slave.
20	SUPERVISION_OFF_DUTY	Unsigned16	0-65535	0	ms	S/ O/S	Time between supervision commands. The zero value indicating that the OFF_DUTY is disabled.
21	CONTROL_OFF_DUTY	Unsigned16	0-65535	0	ms	S/ O/S	Time between control commands. The zero value indicating that the OFF_DUTY is disabled.

Idx	Parameter	Data Size (length)	Valid Range/Options	Default Value	Unit	Store / Mode	Description
22	BYPASS_DIRECTION	Unsigned8	0: TCP to Serial 1: Serial to TCP	0	na	S / O/S	Define the data direction. If the direction is "Serial to TCP" the device has only the Bypass functionality.
23	ON_APPLY	Unsigned8	0:None, 1: Apply	None	E	S / O/S	Apply the changes made in the modbus blocks.
24	SCAN_TIME	Float				D/RO	Scan Time of the Serial Modbus
25	UPDATE_EVT	DS-73			Na	D	This alert is generated by any change to the static data.
26	BLOCK_ALM	DS-72			Na	D	The block alarm is used for all configuration, hardware, connection failure or system problems in the block. The cause of the alert is entered in the subcode field. The first alert to become active will set the Active status in the Status attribute. As soon as the Unreported status is cleared by the alert reporting task, another block alert may be reported without clearing the Active status, if the subcode has changed.
27	IP_SLAVE_7	VisibleString(32)		Spaces		S	Slave IP address 7.
28	IP_SLAVE_8	VisibleString(32)		Spaces		S	Slave IP address 8.
29	IP_SLAVE_9	VisibleString(32)		Spaces		S	Slave IP address 9.
30	IP_SLAVE_10	VisibleString(32)		Spaces		S	Slave IP address 10.
31	IP_SLAVE_11	VisibleString(32)		Spaces		S	Slave IP address 11.
32	IP_SLAVE_12	VisibleString(32)		Spaces		S	Slave IP address 12.
33	DEVICE_IDS_7	Array Unsigned8 [32]		0		S	List of Device Ids Modbus for the respective IP Slave 7.
34	DEVICE_IDS_8	Array Unsigned8 [32]		0		S	List of Device Ids Modbus for the respective IP Slave 8.
35	DEVICE_IDS_9	Array Unsigned8 [32]		0		S	List of Device Ids Modbus for the respective IP Slave 9.
36	DEVICE_IDS_10	Array Unsigned8 [32]		0		S	List of Device Ids Modbus for the respective IP Slave 10.
37	DEVICE_IDS_11	Array Unsigned8 [32]		0		S	List of Device Ids Modbus for the respective IP Slave 11.
38	DEVICE_IDS_12	Array Unsigned8 [32]		0		S	List of Device Ids Modbus for the respective IP Slave 12.
39	TIME_DELAY	Unsigned 16		0	millise c	S	Waiting time, in milliseconds, between the reception (Rx) and the next transmission (Tx) of MB-700.
40	TCP_SCAN_TIME	Float				D/RO	Time used for the Ethernet port to scan the Modbus variables.

Legend: E – Enumerated parameter; na – Non Dimensional Parameter; RO – Read Only D – Dynamic; N – non volatile; S – static

Block CCSM - Concentrate Supervision Master

Overview

This block supplies information to monitor a Modbus slave device connected to the serial port of the MB-700 with supervision functionality. This functionality is obtained remapping Modbus variables of the Modbus device into parameters of this block.

Description

In this block user must inform to the MB-700 the MODBUS addresses of the devices in the MODBUS network.

Note	
The standard of the Modbus protocol specifies the division of the address range to the variables	
•	0001 to 9999 → Digital Outputs
•	10001 to 19999 → Digital Inputs
•	30001 to 39999 → Analog Inputs
•	40001 to 49999 → Analog Outputs

The CCSM block allows user to view and change variables of the MODBUS addresses configured.

A) Configuring points to be supervised

MODE OF OPERATION

The MODE_BLK parameter sets the operation mode of this block. Modes supported by the CCSM block are “auto” (automatic, i.e., normal operation) and OOS (Out of Service). The MODE_BLK parameter is composed of: Target, Actual, Permitted and Normal. The target mode is the operation mode set by user. “Actual” is the real operation mode of the block, because it displays the current mode of the block.

Parameters of block configuration (like SLAVE_ADDRESS, B_ADDRESS, F_ADDRESS) cannot be changed if the block is working in the automatic mode. To change parameters user must change Target for “OOS” and only next change parameters of configuration and next change the operation Target for “Auto”. After changing any parameter user will have to change the parameter On_Apply (in the configuration block CCCF) to “Apply” so that these changes have effect. The block will remain in OOS (MODE_BLK. ACTUAL= OOS) while the parameter ON_APPLY is not changed to “Apply”.

Note	
The column Store/Mode of the table of parameters of the CCSM block contains a list of parameters that require the OOS mode to be set before these parameters are changed. For more details please refer to the Function Blocks Manual.	

SUPERVISION WAYS

1 - SCAN_BEHAVIOR Parameter:

User may select this parameter in two modes:

- 1- Using config view
- 2- Not using config view

If user sets the mode “1” will make the MB-700 to get the data from the slave devices in a much faster and optimized way. This will increase the updating of parameters of these blocks that are mapped in the Modbus slave devices.

Note	
Smar devices only support mode “Using Config view”.	

ADDRESSING

1 - SLAVE_ADRR Parameter:

In this parameter user will inform address of the slave device in the Modbus RTU network.

2 - B_ADDRESSi Parameter:

Boolean data. User must type the Modbus addresses of the discrete variables that are required to monitor. Up to 96 boolean points can be monitored.

3 - I_ADDRESSi Parameter:

Integer data. User must type the Modbus addresses of the integer variables that are required to monitor. This parameter allows monitor integer data of 1, 2 or 4 bytes. A reading of 1 or 2 bytes has only one MODBUS address. If the 4 bytes format is selected user will have to see the first MODBUS address. Up to 8 integer variables can be monitored.

4 - P_EU_ADDRESS_Ai/ P_EU_ADDRESS_Bi Parameters:

Percentage data. User must configure the parameters showed below. In the Appendix C there are more details about Scale Conversion. Up to 56 percentage variables can be monitored.

- FROM_EU_100%
- FROM_EU_0%
- TO_EU_100%
- TO_EU_0%

➤ DATATYPE:

It corresponds to the format of the data read from the Modbus slave device. For further details about the available data types, refer to the table in the Appendix C.

➤ MODBUS_ADDRESS_OF_VALUE:

The Modbus addresses of the variable to be monitored must be entered in this parameter.

IMPORTANT

If are necessary integer 4 bytes data or float, user will have only to set the first Modbus address of the variable.

5 - F_ADDRESS_i Parameter:

Float data. User must insert MODBUS address of a Modbus variable in float format. Up to 16 float points can be monitored.

MAKING EFFECTIVE THE NEW CONFIGURATION

User must change the parameter ON_APPLY to “Apply” to validate the new configuration established. To do it, user must access the CCCF block and proceed as indicated.

IMPORTANT

If user do not accomplish this procedure, the new configuration will not be effective. The configuration was sent after writing but the block will only run it after ON_APPLY having been put on “Apply”.

B) Data Supervision**1 - BVALUE Parameter:**

Through this parameter user will visualize boolean variables addressed by the B_ADDRESSi parameters. The block supports up to 96 Boolean that can be mapped for supervision of the Modbus slave device.

2 - IVALUE Parameter:

Through this parameter user will visualize integer variables addressed by the I_ADDRESSi parameters. The block supports up to 8 integer that can be mapped for supervision of the Modbus slave device.

3 - P_EU_VALUE_A/ P_EU_VALUE_B Parameters:

Through these parameters, user will visualize analog variables addressed by P_EU_ADDRESS_i. The block supports up to 56 analog that can be mapped for supervision of the Modbus slave device.

4 - F_VALUE Parameter:

Through this parameter user will visualize float variables addressed by F_ADDRESS_i. The block supports up to 16 float variables that can be mapped for supervision of the Modbus slave device.

C) Supervision status

1 - SCAN_STATUS Parameter:

Status parameter of the scan done by the MB-700 in the communication with serial slave devices.

BIT	Message	Description
0	Last write message Failed	When the value set for NUMBER_RETRANSMISSIONS is reached, and if the MB-700 didn't get to write data properly, the value SCAN_STATUS will indicate "Last write message Failed".
1	Scan failed	When the value set on NUMBER_RETRANSMISSIONS is reached and the MB-700 didn't get an answer from the serial slave, the value of SCAN_STATUS will indicate "Scan Failed".
2	Using configurable view	If user set SCAN_BEHAVIOR equal to one and the communication with the slave is done using View the scan status will indicate "Using Configurable View"
3	Scan Stopped	Indicates if the scan stopped for any reason.

Parameters

Idx	Parameter	Data Type (Length)	Valid Range/ Options	Default Value	Unit	Store/ Mode	Description
1	ST_REV	Unsigned16		0	None	S	
2	TAG_DESC	OctString(32)		Spaces	Na	S	
3	STRATEGY	Unsigned16		0	None	S	
4	ALERT_KEY	Unsigned8	1 to 255	0	None	S	
5	MODE_BLK	DS-69		O/S	Na	S	See Mode Parameter
6	BLOCK_ERR	Bitstring(2)			E	D / RO	
7	SLAVE_ADDRESS	Unsigned8	0 to 255	2		S / O/S	Address of slave device to be scanned.
8	SERIAL_PORT	Unsigned8	1 : P1 2 : P2	1	1	S / O/S	Serial port number where the slave device is connected.
9	SCAN_BEHAVIOR	Unsigned8	0 : Use Config View 1 : Not Use Config View	0	0	S / O/S	Define if will use the configured view to scan the device or not.
10	SCAN_STATUS	Bitstring(2)	See Scan_Status bitstring description	0	E	D / RO	Indicate the communication status with the slave device.
11	BVALUE	96 Boolean		FALSE		N	Boolean value scanned from slave device
12	IVALUE	8 Interge32		0		N	Integer value scanned from slave device.
13	P_EU_VALUE_A	28 Float		0		N	Percent to EU value scanned from slave device
14	P_EU_VALUE_B	28 Float		0		N	Percent to EU value scanned from slave device
15	FVALUE	16 Float		0.0		N	Float value scanned from slave device.
16	B_ADDRESS1	Unsigned16		65535		S / O/S	Modbus address to locate boolean variable
...
111	B_ADDRESS96	Unsigned16		65535		S / O/S	Modbus address to locate boolean variable
112	I_ADDRESS1	DS-264				S / O/S	Modbus address to locate integer variable and length.
...
119	I_ADDRESS8	DS-264				S / O/S	Modbus address to locate integer variable and length.
120	P_EU_ADDRESS_A 1	DS-265				S / O/S	Information to locate percentage variable as well scaling conversion.
...
147	P_EU_ADDRESS_A 28	DS-265				S / O/S	Information to locate percentage variable as well scaling conversion.
148	P_EU_ADDRESS_B 1	DS-265				S / O/S	Information to locate percentage variable as well scaling conversion.

Idx	Parameter	Data Type (Length)	Valid Range/Options	Default Value	Unit	Store/Mode	Description
...
175	P_EU_ADDRESS_B28	DS-265				S / O/S	Information to locate percentage variable as well scaling conversion.
176	F_ADDRESS1	Unsigned16		65535		S / O/S	Modbus address to locate float variable
...
191	F_ADDRESS16	Unsigned16		65535		S / O/S	Modbus address to locate float variable
192	UPDATE_EVT	DS-73			Na	D	This alert is generated by any change to the static data.
193	BLOCK_ALM	DS-72			Na	D	The block alarm is used for all configuration, hardware, connection failure or system problems in the block. The cause of the alert is entered in the subcode field. The first alert to become active will set the Active status in the Status attribute. As soon as the Unreported status is cleared by the alert reporting task, another block alert may be reported without clearing the Active status, if the subcode has changed.

Legend: E – Enumerated parameter; na – Adimensional Parameter; RO – Read Only D – Dynamic; N – non volatile; S – static

Block CCCM- Concentrate Control Master

Overview

The CCCM block supplies a way to change data between a Modbus slave device and another Modbus slave device or Foundation Fieldbus Device to control process applications.

This data exchange occurs following the Fieldbus Foundation specification regarding treatment of communication status. Thus Modbus communication failure with a slave device reflects in the output parameters OUT_XX and/or parameter COMM_STATUS regarding input parameters IN_XX.

Schematic

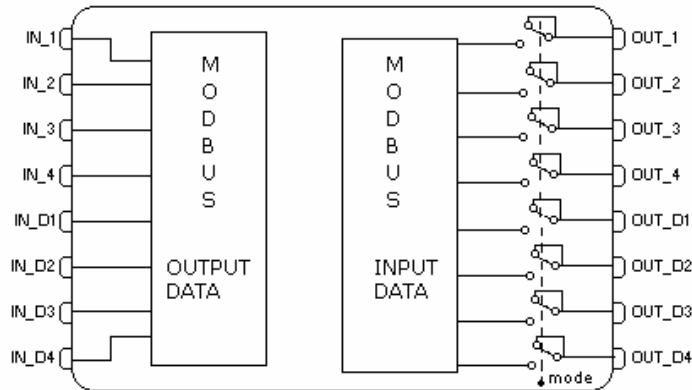

Description

If two devices are Modbus it is necessary that the two devices are in the same network. For example, a slave must be connected in the serial port of the **MB-700** and another might be connected in the Ethernet network or even in another serial port of another **MB-700**. User needs only to inform the Modbus address of each device, addresses of Modbus variables and a **MB-700** internal link connecting the input parameter to the output parameters of the same CCCM block, so that the **MB-700** establishes “peer-to-peer” connection between two devices.

NOTE

User must set the MODE_BLK parameter of the CCCM block to “auto” in order to this block works properly. See description of this parameter in the previous item, CCSM block.

A) Functioning of a communication peer-to-peer in a MODBUS device

Block CCCM must be set to establish communication of data between two slaves through **MB-700**. So user will have to connect the MODBUS addresses of the inputs and outputs.

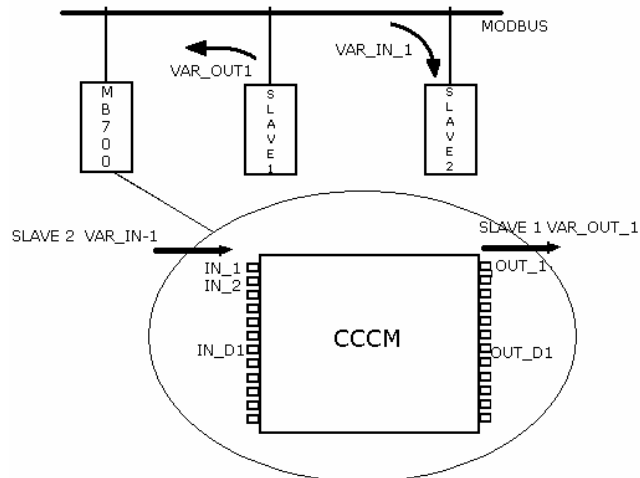

Slave 1 can read a variable. The peer-to-peer function allows that the reading of his variable to be communicated to the other slave using the MB-700 to make this connection and the CCCM block to manage it.

Adopting that the variable is read in the slave 1 the goal is to send this variable, or its value, to the slave 2. The reading of this variable corresponds to a Modbus address that must be informed in the addressing of the CCCM block. This Modbus address is informed at the output of the CCCM block. In the slave 2, where the variable will be transmitted, we connect the input of the CCCM block. The figure below gives an example of this connection in the CCCM block. More details are given on Chapter 5.

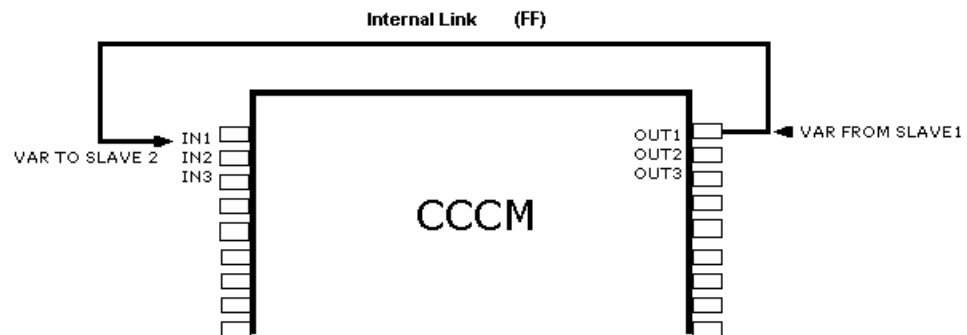

B) Addressing

1. EU_ADDRESS_IN1 to EU_ADDRESS_IN4 Parameters:

In these parameters user must inform Modbus addresses and parameters of the slave that receives the value of the analog variable, i.e., the slave where the value will be sent in the input parameter of the CCCM block. User will have to inform the parameters that are showed below. For further information about Scaling Conversion, refer to the Appendix C:

- ✓ FROM_EU_100%
- ✓ FROM_EU_0%
- ✓ TO_EU_100%
- ✓ TO_EU_0%

✓ DATATYPE

The format for the data among the available types can be selected in this parameter. Refer to the Appendix C for details about data types.

✓ PORT_NUMBER

User must inform the MB-700 port to be used for communication between slaves: Ethernet, P1 or P2.

✓ SLAVE_ADDRESS

In this parameter, it must inform the Modbus address of the slave device.

✓ MODBUS_ADDRESS_OF_VALUE

In this parameter, it must inform the Modbus address of the variable to be written whose value is “y”.

✓ MODBUS_ADDRESS_OF_STATUS

In this parameter, it must inform the Modbus address of the variable to be written in the slave device.

2. EU_ADDRESS_OUT1 to EU_ADDRESS_OUT4 Parameters:

In these parameters user will have to inform Modbus address and parameters of the slave that informs the value of the analog variable, that is, the variable to be read.

User must inform the following parameters:

✓ FROM_EU_100%

✓ FROM_EU_0%

✓ TO_EU_100%

✓ TO_EU_0%

✓ DATATYPE

The format for the data among the available types can be selected in this parameter. Refer to the Appendix C for details about data types.

✓ PORT_NUMBER:

User must inform the MB-700 port to be used for communication between slaves: Ethernet, P1 or P2.

✓ SLAVE_ADDRESS

In this parameter, it must inform the Modbus address of the slave device.

✓ MODBUS_ADDRESS_OF_VALUE

In this parameter, it must inform the Modbus address of the variable read from slave.

✓ MODBUS_ADDRESS_OF_STATUS

In this parameter, it must inform the address of status of the variable read from slave.

3. EU_ADDRESS_IN_D1 to EU_ADDRESS_IN_D2 Parameters:

In this parameters user will inform the Modbus addresses and parameters of the slave where the boolean value will be written. User must inform the following parameters:

✓ PORT_NUMBER

User must inform the MB-700 port to be used for communication between slaves: Ethernet, P1 or P2.

✓ SLAVE_ADDRESS

In this parameter, it must inform the Modbus address of the slave device.

✓ MODBUS_ADDRESS_OF_VALUE

In this parameter, it must inform the Modbus address where the variable value will be written. Inform the address of the Modbus variable of the slave device to be written whose value is the value of input parameter IN_DX.

✓ MODBUS_ADDRESS_OF_STATUS

In this parameter, it must inform the address of status of the variable read from slave.

4. EU_ADDRESS_OUT_D1 to EU_ADDRESS_OUT_D2 Parameters:

In these parameters user will inform Modbus addresses and parameters of the slave that informs the value of the digital variable, that is., the variable to be read. User will have to inform the following parameters.

✓ PORT_NUMBER

User must inform the MB-700 port to be used for communication between slaves: Ethernet, P1 or P2.

✓ SLAVE_ADDRESS

In this parameter, it must inform the Modbus address of the slave device.

✓ MODBUS_ADDRESS_OF_VALUE

In this parameter, it must inform the Modbus address of the variable read from slave that will be available in the output parameter OUT_DX of this block.

✓ MODBUS_ADDRESS_OF_STATUS

In this parameter, it must inform the address of status of the variable read from slave.

Sending the Configuration to the MB-700

User must change the ON_APPLY parameter to “Apply” to update the new configuration made. To do it, user must access the CCCF block and proceed as indicated.

IMPORTANT

If the user does not accomplish this procedure the selected configuration will not be sent to the MB-700. The configuration was updated after writing, but the block will execute again after ON_APPLY having been put on “Apply”.

C) Monitoring data

- Analog input monitoring parameters of the block CCCM: IN1, IN2, IN3, IN4.
- Analog output monitoring parameters of the block CCCM: OUT1, OUT2, OUT3, OUT 4.
- Digital input monitoring parameters of the block CCCM: IN_D1, IN_D 2, IN_D 3, IN_D 4.
- Digital output monitoring parameters of the block CCCM: OUT_D1, OUT _D2, OUT _D3, OUT_D4.

D) Supervision Status

1 - Parameter COMM_STATUS

This parameter indicates if the communication between slaves was established properly. If the correspondent bit is in logic level 1 this means there was an error during writing/reading of the respective parameter.

Bit	Variable
0	BAD COMM MOD_VAR_IN1
1	BAD COMM MOD_VAR_IN2
2	BAD COMM MOD_VAR_IN3
3	BAD COMM MOD_VAR_IN4
4	BAD COMM MOD_VAR_IN_D1
5	BAD COMM MOD_VAR_IN_D2
6	BAD COMM MOD_VAR_IN_D3
7	BAD COMM MOD_VAR_IN_D4
8	BAD COMM MOD_VAR_OUT1
9	BAD COMM MOD_VAR_OUT2
10	BAD COMM MOD_VAR_OUT3
11	BAD COMM MOD_VAR_OUT4
12	BAD COMM MOD_VAR_OUT_D1
13	BAD COMM MOD_VAR_OUT_D2
14	BAD COMM MOD_VAR_OUT_D3
15	BAD COMM MOD_VAR_OUT_D4

Parameter Status

Each input or output parameter has a correspondent status. The slave device through configuration of the MODBUS_ADDRESS_OF_STATUS might update this status. This happens only if the slave device has a status (this status follows the standard **Fieldbus Foundation™**). See more details of how to set this status in the Function Blocks manual. In case it is not configured, the parameter MODBUS_ADDRESS_OF STATUS of the CCCM automatically updates the status to “Good Non Cascade” when the communication with slave is OK or “Bad No Communication with last value” and “Non-Specific”, if communication fails.

Parameters

Idx	Parameters	Data Type (Length)	Valid Range/Options	Default Value	Unit	Store / Mode	Description
1	ST_REV	Unsigned16		0	None	S	
2	TAG_DESC	OctString(32)		Spaces	Na	S	
3	STRATEGY	Unsigned16		0	None	S	
4	ALERT_KEY	Unsigned8	1 to 255	0	None	S	
5	MODE_BLK	DS-69		O/S	Na	S	See Mode Parameter
6	BLOCK_ERR	Bitstring(2)			E	D / RO	
7	COMM_STATUS	Bitstring(2)		0	E	D / RO	Indicate if communication from slave is good or not (each bit corresponds to a Modbus variable).
8	IN1	DS-65				N	Analog input 1
9	EU_ADDRESS_IN1	DS-266				S / M	Information to generate constants A and B em equation $Y=A*X+B$ plus the addresses in a slave device.
10	IN2	DS-65				N	Analog input 2
11	EU_ADDRESS_IN2	DS-266				S / M	Information to generate constants A and B em equation $Y=A*X+B$ plus the addresses in a slave device.
12	IN3	DS-65				N	Analog input 3
13	EU_ADDRESS_IN3	DS-266				S / M	Information to generate constants A and B em equation $Y=A*X+B$ plus the addresses in a slave device.
14	IN4	DS-65				N	Analog input 4
15	EU_ADDRESS_IN4	DS-266				S / M	Information to generate constants A and B em equation $Y=A*X+B$ plus the addresses in a slave device.
16	IN_D1	DS-66				N	Discrete input 1
17	ADDRESS_IN_D1	DS-267				S / O/S	Addresses in a slave device.
18	IN_D2	DS-66				N	Discrete input 2
19	ADDRESS_IN_D2	DS-267				S / O/S	Addresses in a slave device.
20	IN_D3	DS-66				N	Discrete input 3
21	ADDRESS_IN_D3	DS-267				S / O/S	Addresses in a slave device.
22	IN_D4	DS-66				N	Discrete input 4
23	ADDRESS_IN_D4	DS-267				S / O/S	Addresses in a slave device.
24	OUT1	DS-65				N / Man	Analog output 1
25	EU_ADDRESS_OUT1	DS-266				S / M	Information to generate constants A and B em equation $Y=A*X+B$ plus the addresses in a slave device.
26	OUT2	DS-65				N / Man	Analog output 2
27	EU_ADDRESS_OUT2	DS-266				S / M	Information to generate constants A and B em equation $Y=A*X+B$ plus the addresses in a slave device.
28	OUT3	DS-65				N / Man	Analog output 3
29	EU_ADDRESS_OUT3	DS-266				S / M	Information to generate constants A and B em equation $Y=A*X+B$ plus the addresses in a slave device.
30	OUT4	DS-65				N / Man	Analog output 4
31	EU_ADDRESS_OUT4	DS-266				S / M	Information to generate constants A and B em equation $Y=A*X+B$ plus the addresses in a slave device.
32	OUT_D1	DS-66				N / Man	Discrete output 1
33	ADDRESS_OUT_D1	DS-267				S / O/S	Addresses in a slave device.
34	OUT2_D2	DS-66				N / Man	Discrete output 2
35	ADDRESS_OUT_D2	DS-267				S / O/S	Addresses in a slave device.
36	OUT_D3	DS-66				N / Man	Discrete output 3
37	ADDRESS_OUT_D3	DS-267				S / O/S	Addresses in a slave device.
38	OUT_D4	DS-66				N / Man	Discrete output 4
39	ADDRESS_OUT_D4	DS-267				S / O/S	Addresses in a slave device.
40	UPDATE_EVT	DS-73			Na	D	This alert is generated by any change to the static data.
41	BLOCK_ALM	DS-72			Na	D	The block alarm is used for all configuration, hardware, and connection failure or system problems in the block. The cause of the alert is entered in the subcode field. The first alert to become active will set the Active status in the Status attribute. As soon as the Unreported status is cleared by the alert reporting task, another block alert may be reported without clearing the Active status, if the subcode has changed.

Legend: E – Enumerated parameter; na – Adimensional Parameter; RO – Read Only, D – Dynamic; N – non volatile; S – static

Block CCDL – Concentrate Data Logger

Overview

This block supplies a mechanism to search data stored in Modbus slave devices in an optimized way. A Modbus variable specified in the configuration will be used to indicate whether it is necessary to scan stored data whose Modbus address are entered by user.

Description

Optimized mechanism to bring stored data from the LC700.

- To start the FIFO Data Logger block of the LC700 when the communication with a MB-700 master (for example a HMI) fails, the CCDL block sends a Modbus command to the variable in the LC700 pointed by STOP_SCAN_ADDRESS. The block writes TRUE in the variable when it is necessary to enable and FALSE when it is required to disable the FIFO data logger.
- If data supervision is normal (for example, if a HMI system communicates normally with a supervision block-CCSM) in the scan of the CCDL block, it will monitor the Modbus variable pointed by NEED_SCAN_ADDRESS to know if there is any data in the Data Logger. If the variable is not zero it indicates that there's data in the Data Logger. Parameter LOGGER_ADDRESS points to an address of beginning of the data logger block (FIFO.CTW). The parameter NUM_REGISTER shows the amount of registers stored on the CCDL block.

1 – Parameter TYPE_OF_LOG

It sets the time_stamp of the data logger.

2 – Parameter P_EU_ADDRESS_A1

It sets the conversion scale and the data format of the FIFO block data logger (these parameters must have the same configuration of the respective FIFO data logger in the LC700). For further information about Scale Conversion, refer to the Appendix C. User will have to set the following parameters:

- ✓ FROM_EU_100%
- ✓ FROM_EU_0%
- ✓ TO_EU_100%
- ✓ To_EU_0%

✓ DATATYPE

Choose the format of data read from the device. Data types supported by the data logger (they will be converted to float) are: float and Integer16.

✓ MODBUS_ADDRESS_VALUE

Not used.

- The CCDL can store up to 280 registers. If the CCDL block is not enough to store all data stored in the FIFO, it is possible to put blocks in cascade as many times as necessary and set all of them with the same information (MODE_BLK, SLAVE_ADDRESS, NEED_SCAN_ADDRESS, LOGGER_ADDRESS, etc). So when the data logged brought from the FIFO block do not fit in the CCDL and there is another CCDL block set for that FIFO, this block will receive the rest of the data log. The CCDL block indicates in the parameter NEXT_BLOCK_LOG which is the next block containing the rest of the data logged.

Parameters

Idx	Parameter	Data Type/ Length	Valid Range/ Options	Default Value	Units	Store / Mode	Description
1	ST_REV	Unsigned16		0	None	S	
2	TAG_DESC	OctString(32)		Spaces	Na	S	
3	STRATEGY	Unsigned16		0	None	S	
4	ALERT_KEY	Unsigned8	1 to 255	0	None	S	
5	MODE_BLK	DS-69		O/S	Na	S	See Mode Parameter
6	BLOCK_ERR	Bitstring(2)			E	D / RO	
7	SLAVE_ADDRESS	Unsigned8	0 to 255	2		S / O/S	Address of slave device to be scanned.
8	SERIAL_PORT	Unsigned8	1 : P1 2 : P2	1	1	S / O/S	Serial port number where the slave device is connected.
9	SCAN_STATUS	Bitstring(2)	See the Scan Status	0	E	D/RO	Indicate the communication status with the slave device.
10	NEED_SCAN_ADDRESS	Unsigned16	1-49999	0	E	S / O/S	This is the Modbus address of a flag that indicates if it is necessary to scan the logged data.
11	CLEAR_LOG_ADDRESS	Unsigned16	1-9999	0	E	S / O/S	Address of variable in the Slave Modbus Device to clear the data logger. It can be used to clear data logger after reading it. If the address is the default (0), then this mechanism is disabled.
12	NEED_SCAN_COUNTER	Unsigned16		0	E	D / RO	It indicates the number of scans for the logged data. This variable may be used by the OPC Server to trigger a scan command to red LOG_FVALUE _x and TIME_STAMP _x .
13	TYPE_OF_LOG	Unsigned8	0:Only last time stamp 1:Every sample 2:No time stamp	0	E	S / O/S	Selection of log type.
14	P_EU_ADDRESS_A1	DS-265				S / O/S	Information to locate percentage/FLOAT variable as well scaling conversion.
15	LOGGER_ADDRESS	Unsigned16		0	E	S / O/S	Modbus address of data logger beginning
16	NUM_REGISTER	Unsigned16		0	E	D / RO	Number of logged FIFO registers
17	STOP_SCAN_ADDRESS	Unsigned16	0 - 9999	0	E	S	MB-700 may force the trigger of data logger writing TRUE to a Modbus variable in the slave Modbus device.
18	NEXT_BLOCK_LOG	Visiblestring(32)				S	Block tag of next CCDL block associated to this data logger.
19	LOG_FVALUE_1	28 Float		0.0		N/RO	Float value scanned from slave device.
...
28	LOG_FVALUE_10	28 Float		0.0		N/RO	Float value scanned from slave device.
29	TIME_STAMP_1	28 Time Value				N/RO	Time stamp of samples in LOG_FVALUE1
...
38	TIME_STAMP_10	28 Time Value				N/RO	Time stamp of samples in LOG_FVALUE10
39	UPDATE_EVT	DS-73			Na	D	This alert is generated by any change to the static data.
40	BLOCK_ALM	DS-72			Na	D	The block alarm is used for all configuration, hardware, connection failure or system problems in the block. The cause of the alert is entered in the subcode field. The first alert to become active will set the Active status in the Status attribute. As soon as the Unreported status is cleared by the alert reporting task, another block alert may be reported without clearing the Active status, if the subcode has changed.

Legend: E – Enumerated parameter; na – Non Dimensional Parameter; RO – Read Only, D – Dynamic; N – non volatile; S – static

ADDING MODBUS TO THE MB-700

MB-700 as Serial MODBUS Master

Scenario

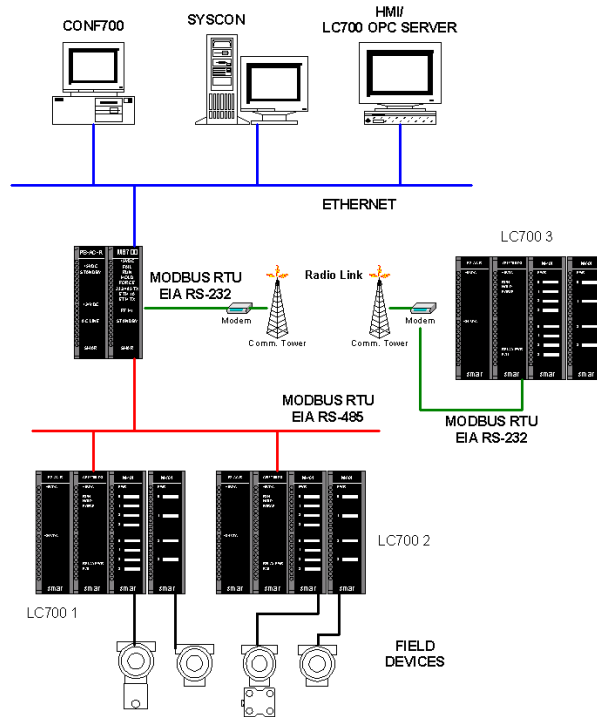

Fig. 5.1 – MB-700 as a serial MODBUS master

Description

In this scenario the MB-700 has the following roles simultaneously, when the Bypass Direction parameter is set for "TCP to Serial".

- Bypass (TCP/IP to serial): The MB-700 passes the MODBUS message transmitting it to a lower level of the network. The MB-700 acts as TCP/IP Modbus to serial Modbus RTU (485 ou 232) converter.
- Concentrator: Modbus variables of the devices are read processed (Data Type conversion and scale) and stored in parameters of the CCSM block. So instead of the HMI communicating directly with the slave devices it will communicate directly with the MB-700 only.
- Peer-to-peer: Two Modbus slaves change data between each other. Peer-to-peer function allows it. Slaves might be in different Modbus networks and even they can change data between each other.

The system above is indicated for remote control operations, where the process is located in a not easily accessible area, a place too far from the supervision system. User does not need to go to the area, it is only necessary that he is connected to the Ethernet network.

The MB-700 has two serial ports EIA-232 and EIA-485 allowing connection with logic controllers through a MODBUS network or through a MODEM. Using the EIA-485 port it is possible to create a multi drop network with logic controllers or to integrate an already existent network. For remote control, in distant locations, a modem or radio might be used in the EIA-232 port to establish communication between the system HMI and configuration systems with controllers in the process plant.

In this application the MB-700 has two basic functions: MODBUS bypass and data concentrator. The Modbus bypass happens when a MODBUS data reaches the MB-700, that is., CONF700 (or any other Modbus configuration system) sends commands to set any slave device in the Modbus sub net. In this case the MB-700 ignores the message and passes it to the target slave. MB-700 also has the functionality of concentrator of data.

Instead of the supervision system accessing a field device in particular, it just searches for data monitored in MB-700 memory. Data collected are sent within a determinate time base to the MB-700 and the supervision system looks for these data directly in the MB-700 memory increasing speed of access because the HMI does not need to access the field device directly.

The MB-700 is set through Syscon. Fieldbus Foundation blocks CCCF and CCSM set the concentrator function of the MB-700 and the CCCM block sets the peer-to-peer communication. The MB-700 has an IP within an Ethernet used for communication between the operation system and the MB-700. Each slave of the network has a MODBUS address that must be informed to the SYSCON. Each I/O and the respective addresses must also be informed to the SYSCON. In the above configuration the peer-to-peer may for example be easily implemented.

OFF LINE Configuration

IMPORTANT

Before the user starts configuring the MB-700, it is necessary read first chapter 4 of this manual “MB-700 Function Blocks”.

A) Configuring the IP of the MB-700

Set the IP of the MB-700 connecting it to the sub net, for more details about how to configure the IP address, refer to the chapter 2 “Connecting the MB-700 to the Sub net”.

B) Initializing the SYSCON

- Add the MB-700 to the Syscon. Start SYSCON.
- Click at *Project* → *New* → *Project*. After, click at *Fieldbus Networks* → *New Fieldbus*.
- Select *Expand* to open an auxiliary window. In this new window, right-click in *New* → *Bridge*. Select the manufacturer “Smar”, and then the device “MB-700”;
- Save it.

For further details, see SYSCON manual and the chapter 3 of this manual.

IMPORTANT

The user must be certain that Smar.DFIOLEServer.0 is set in the Communication Settings menu. Otherwise it won’t get to communicate the MB-700 and SYSCON.

In the item below, the necessary minimum configuration is explained for the MB-700 acts as “Bypass”, “Concentrator” and “Peer-to-peer”.

C) Configuring Blocks

1) MB-700 working as Bypass

In order to the MB-700 works as Bypass, it is necessary to configure just the Resource and CCCF blocks.

RESOURCE block

Steps to configure the Resource block:

- The only necessary parameter to be set here is MODE_BLK. Be sure that MODE_BLK.TARGET = “Auto”.
- Right click over <VB_VFD>. A new window will open. Click at *New Block*.

- Select RESOURCE block. Right click the block created and then select *Off Line Characterization*.
- Find the parameter MODE_BLK.TARGET and put it in "Auto".

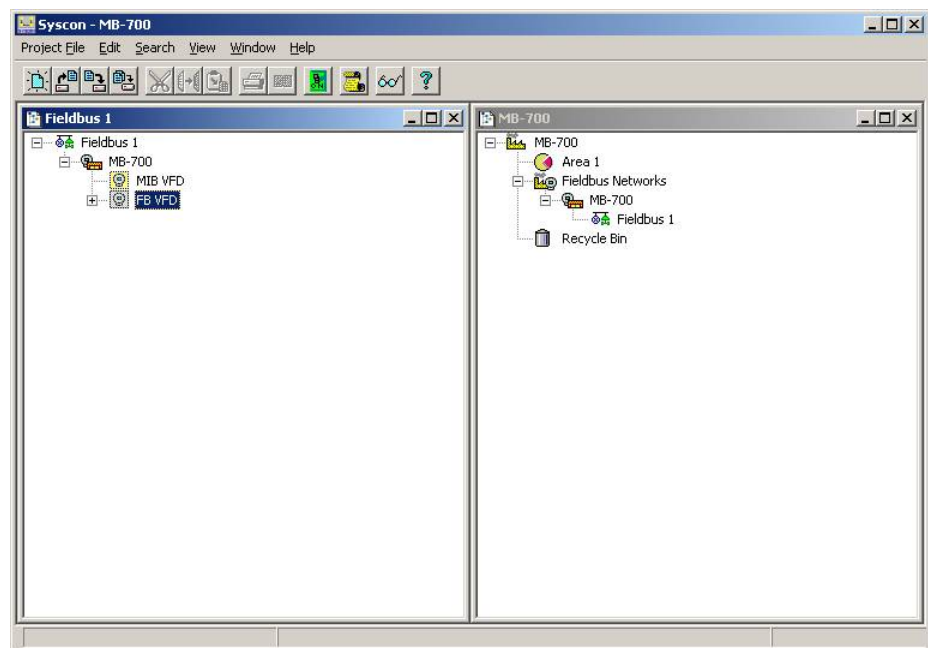
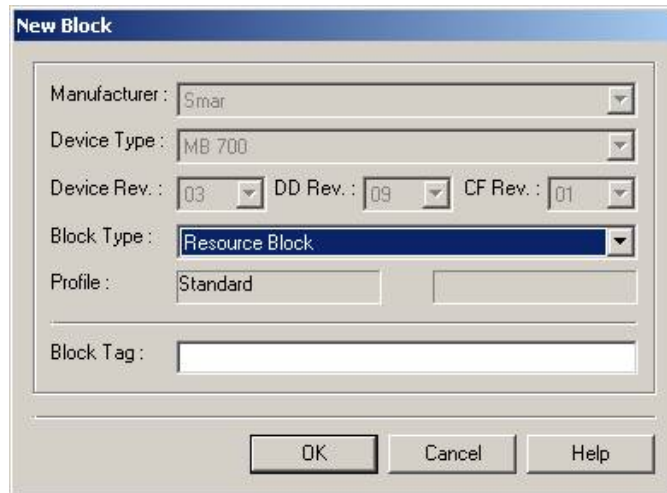

CCCF Block

Steps to configure the CCCF block:

- In the SYSCON find the MB-700.
- Right click with the mouse over <VB_VFD>. A new window will appear. Select *New Block*.
- Find the CCCF block and next insert it. Right click over the block and next select *Off Line Characterization*.

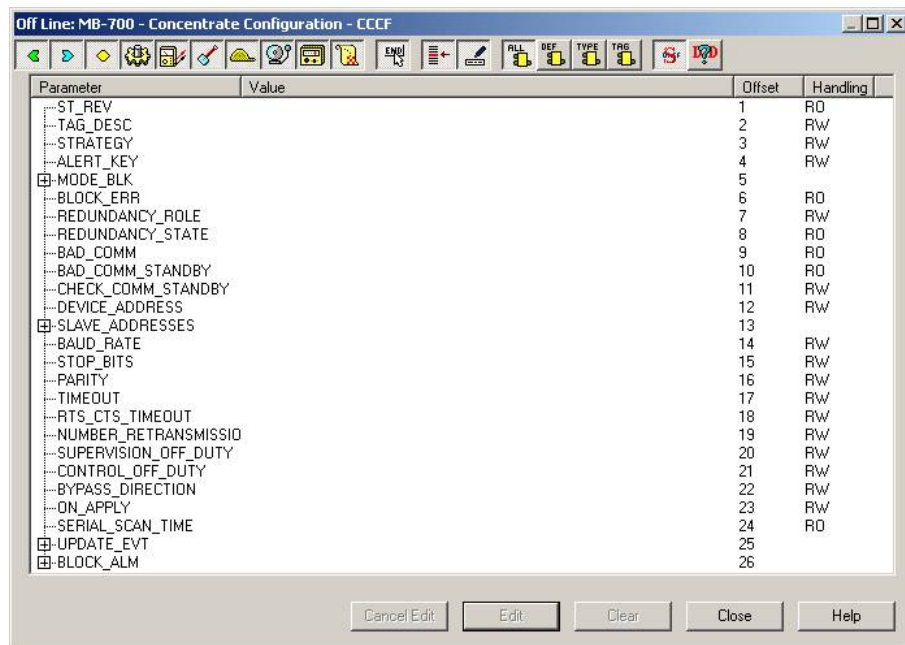

The following parameters must be adjusted:

- ✓ BAUD_RATE: Adjust to 57600
- ✓ BYPASS_DIRECTION: TCP to Serial.
- ✓ NUMBER_RETRANSMISSIONS: Choose "3".
- ✓ TIMEOUT: "1000" (1000 ms).
- ✓ MODE_BLK: Select "Auto".
- ✓ DEVICE_ADDRESS: Make sure that in the MODBUS network there is not any other address with the number shown for this parameter. Default: 247.
- ✓ ON_APPLY: Set this parameter for "Apply".

To have best visualization, rename the blocks which have created. Right click with the mouse over Block 1(where a RESOURCE block must have added). A menu will open.

- User should click at "Attributes" and change the block tag according to the convenience. The same might be done to Block1, just calling the tag of this block CCCF.
- At the end, a table like below must appear on Syscon.

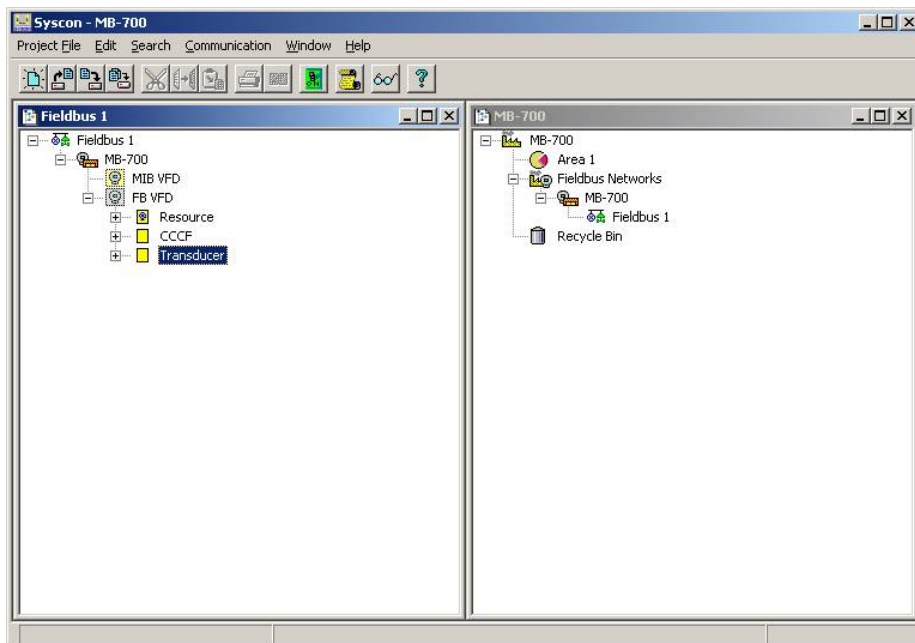

2) MB-700 working as Concentrator

For the MB-700 works as Concentrator, it is necessary to configure, besides the previous blocks, the CCSM block.

CCSM Block

Steps to configure the CCSM block:

<i>Note</i>	
The MODBUS addresses shown have the following addressing:	
✓	0001 to 9999 → Digital Outputs
✓	10001 to 19999 → Digital Inputs
✓	30001 to 39999 → Analog inputs
✓	40001 to 49999 → Analog outputs

In a few moments user will have to inform to the SYSCON MODBUS addresses of the devices. In case of data in the integer format with 4 bytes and float user will always note ONLY the first address, once these data types use 2 positions.

- On the SYSCON find the MB-700.
- Right click with the mouse over <VB_VFD>. A window will appear, the user will have to click at *New Block*.
- Next select CCSM block. Right click with the mouse in the block it just have created and next select *Off Line Characterization*.
- Set MODE_BLK.TARGET= "Auto".
- The parameter SLAVE_ADDR must contain the address of the LC700 target, in this case LC700 1 or the address of the slave within the Modbus network of the slave. In this current case this address is 1.
- SERIAL_PORT will be set for P1 in order to communication through ports EIA-232 and EIA-485.

<i>Note</i>	
If user is using Smar Modbus Slave Devices will be able to change the parameter SCAN_BEHAVIOR to "Using Config View" and this way will enable a much faster communication between MB-700 and slave devices.	

In the proposed scenario in the picture 5.1, the LC700 1 has one I/O card connected to eight digital discrete switches, eight digital outputs represented by LEDs and two inputs for the two transmitters.

Consider that the LC700 has address 1 within that network and it is required to set points of the table presented next. Note that the MODBUS addresses of the input variables to be monitored must be also informed.

<i>Input/Output</i>	<i>Data Type</i>	<i>Modbus Adresses</i>
Led 1	Digital	00001
Led 2	Digital	00002
Led 3	Digital	00003
Led 4	Digital	00004
Led 5	Digital	00005
Led 6	Digital	00006
Led 7	Digital	00007
Led 8	Digital	00008
Switch 1	Digital	10001
Switch 2	Digital	10002
Switch 3	Digital	10003
Switch 4	Digital	10004
Switch 5	Digital	10005
Switch 6	Digital	10006
Switch 7	Digital	10007
Switch 8	Digital	10008
Transmitter 1	Percentage	30001-30002
Transmitter 2	Percentage	30003-30004

- In the SYSCON right click with the mouse over the block recently created named CCSM.
- Click at *Off Line Characterization.*]

In this window user will find the parameters B_ADDRESS1 to B_ADDRESS96.

- Click at B_ADDRESS1 and type in the field in blank the correspondent MODBUS address, that is, 10001.
- Next click at the *End Edit* button.
- Repeat the same procedure for B_ADDRESS2 to B_ADDRESS8 adding MODBUS addresses to the ON-OFF switches according to the table established.

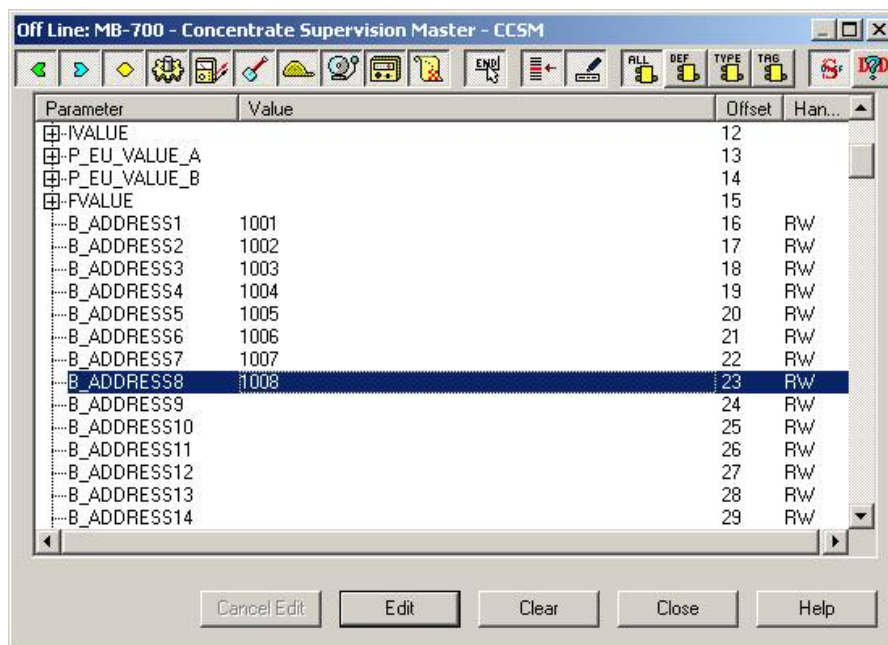

The user needs now to see the inputs of the transmitters. In the above window search for the parameters P_EU_ADDRESS_A1 to P_EU_ADDRESS_A28. Click at the parameter P_EU_ADDRESS_A1. User will set the following parameters:

⇒ FROM_EU_100%

Inform the maximum value to the input variable read in the transmitter 1.

⇒ FROM_EU_0%

Inform the minimum value of the variable read in the transmitter 1.

⇒ TO_EU_100%

Inform the maximum value of the parameter P_EU_VALUE_A[0].

⇒ TO_EU_0%

Inform the minimum value of the parameter P_EU_VALUE_A[0].

⇒ DATATYPE.

Choose the format to the Modbus variable read from the slave device. For further details about the available data types, refer to the table in the Appendix C.

⇒ MODBUS_ADDRESS_OF_VALUE.

Type the address 30001, where it is connected the value read from transmitter 1. According to the type of data used in the variable reading the transmitter will use one or two addresses. Only the first address will be informed.

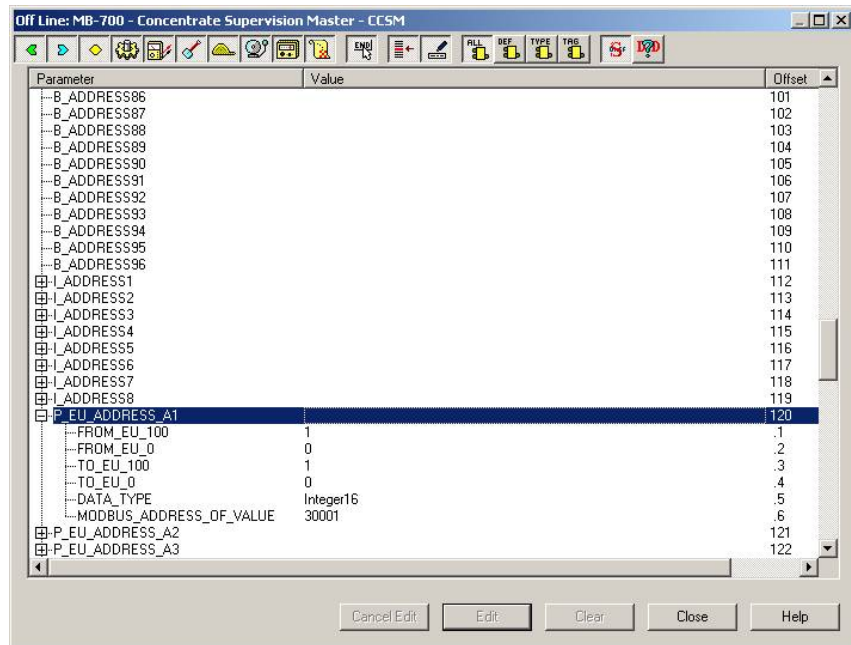

After finishing this configuration the user must have a window similar to:

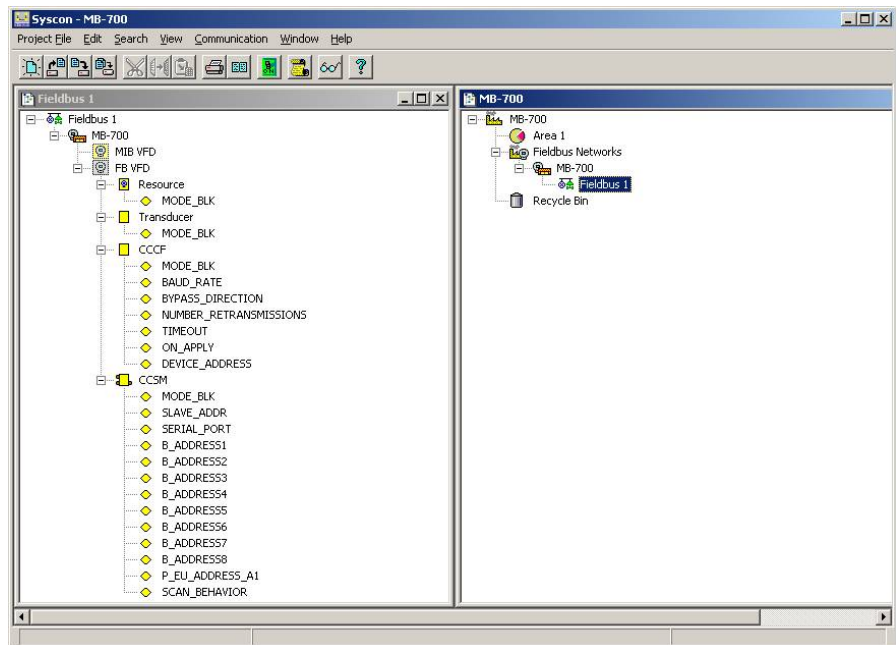

3) MB-700 working as Peer-to-peer

For the MB-700 works as Peer-to-peer between Modbus devices in the same serial net, it is necessary to configure, besides the Resource and CCCF blocks, the CCCM block.

CCCM Block

Steps to configure the CCCM Block.

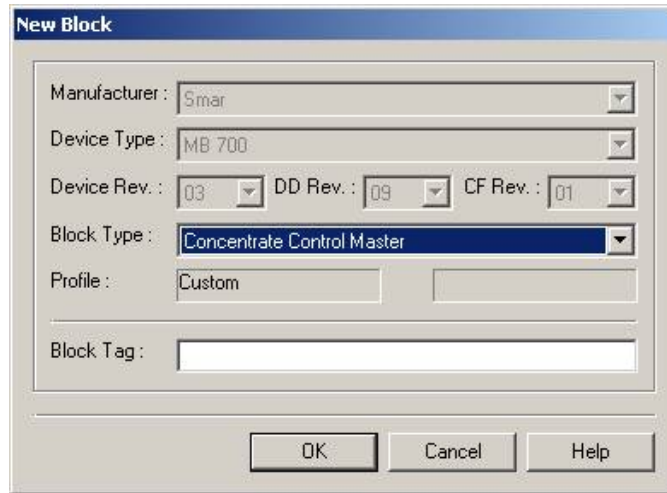

After inserting this block, the Fieldbus window should be similar to:

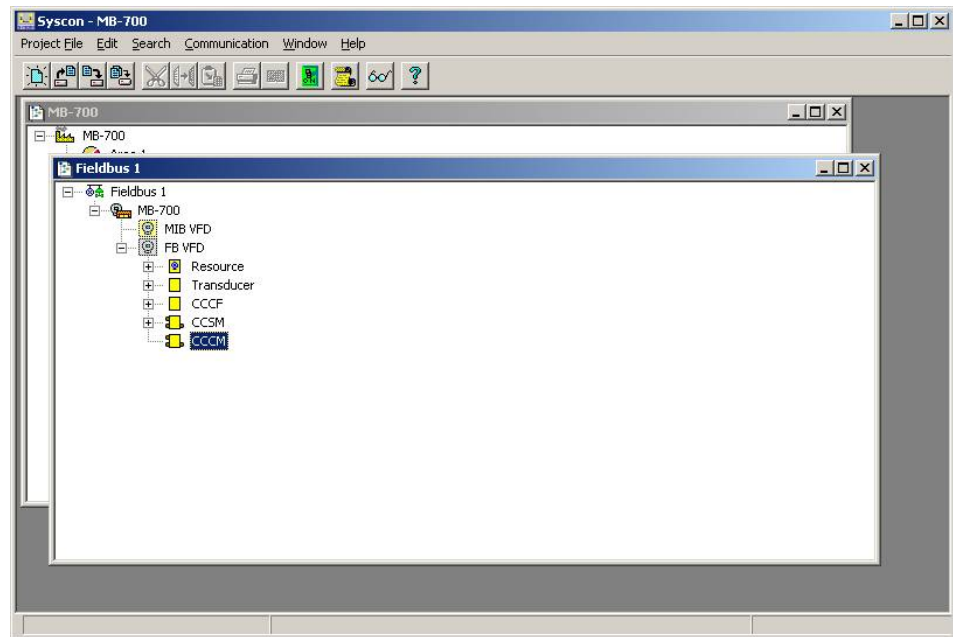

Change MODE_BLK to “Auto”. Suppose slave 1 has a transmitter connected to one of its inputs. Or suppose this MODBUS variable is the output of a LC700 function block. Find EU_ADDRESS_OUT1. Click at this parameter. Configure:

⇒ FROM_EU_100%

Inform the maximum value of input variable read from the LC700 Function Block.

⇒ FROM_EU_0%

Inform the minimum value of the Modbus variable read from the LC700 system.

⇒ TO_EU_100%

Inform the maximum value of the variable to be monitored.

⇒ TO_EU_0%

Inform the minimum value of the variable to be monitored.

⇒ DATATYPE

Choose the format for the data. For further details about the available data types, refer to the table in the Appendix C.

⇒ PORT_NUMBER

Set the port P1. P1 is selected because the communication is done through the serial ports of the MB-700.

⇒ SLAVE_ADDRESS

Insert the number of MODBUS slave.

⇒ MODBUS_ADDRESS_OF_VALUE

Insert the MODBUS address of the data input in the slave device where it is connected the read variable, either a function block output or input.

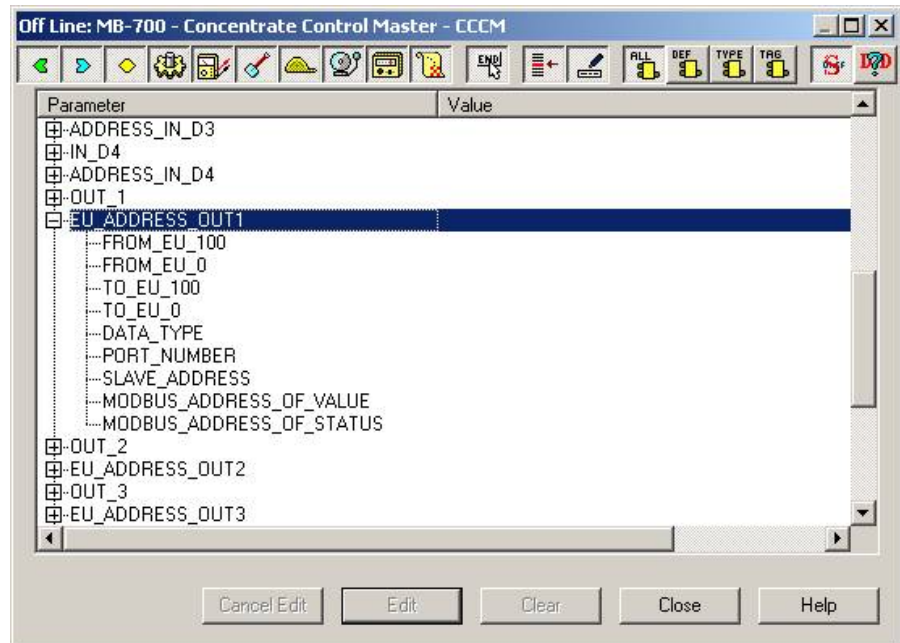

User will set where the read data will be written, that is, the output of the slave2.

Find the parameter EU_ADDRESS_IN1. Inform the required parameters. They are similar to the parameters EU_ADDRESS_OUT1 of the CCCM block. However SLAVE_ADDRESS must be equal to the value of the address of the second slave of the MODBUS network.

In the parameter MODBUS_ADDRESS_OF_VALUE, the MODBUS address must be informed. In this case, choose address 40001, an analog output of the slave 2 of the MODBUS network. This configuration always follows this rule. A data is read in an input of a slave 1. We associate it in the CCCM block with an output parameter. An input parameter of the CCCM block has associated to it a data output of the slave 2.

To finish we only need to set the CCCM in the logic diagram.

- In the SYSCON, right click with the mouse on *Area 1*.
- Select *New Process Cell*.
- In *Process Cell 1* right click on *Expand*.
- In the new window, right click over *Process Cell1* and select *New Control Module*.
- In *Control Module 1*, right click it and select *Strategy*. At the end, user will have 4 windows opened:

- ✓ One main window with the name of the file
- ✓ A Process Cell window
- ✓ A Fieldbus Window
- ✓ A Control Module Window

In the *Fieldbus* window drag the CCCM icon to inside the *Control Module* window. SYSCON will insert the CCCM block in this window.

Click at the link button. With the right button of the mouse click at the CCCM block in the window *Control Module*. Select **Out1**. Make a link from the input **In1** of this same block. SYSCON will make the link the between slaves.

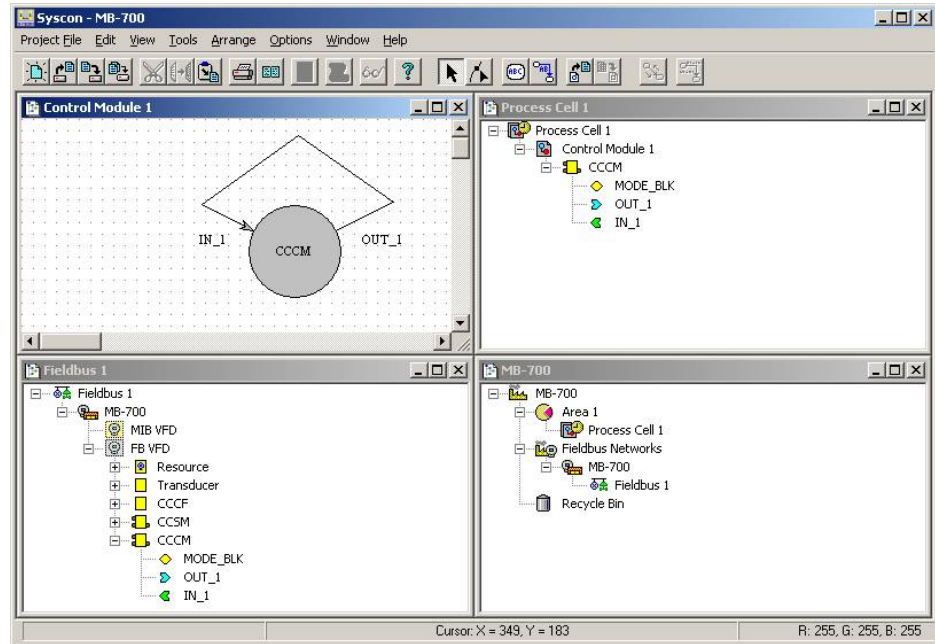

D) Configuration Download

Before starting the communication, the user must do the following procedure:

- In the main Window. In right click over the first item of this Window. In the current example the project was called MB-700.
- Select *Export tags*. A window will be open like below asking where the file with the tags will be saved.
- Hit the Save button.

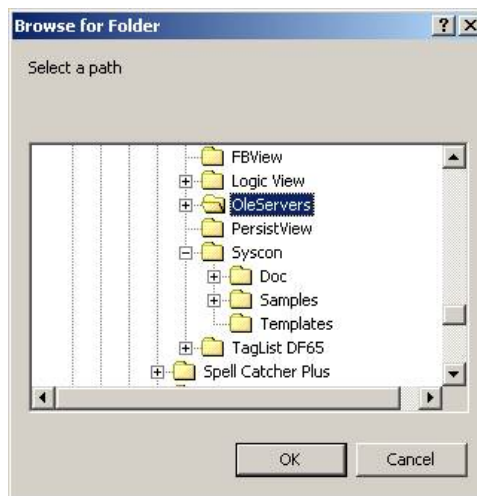

In the button ON LINE start the communication with the MB-700.



- In case the communication is not established, right click with the mouse over *Bridge* and select *Attributes*.
- In the field *Device ID*, check if the device is recognized. Select the correspondent number of the device. See the serial number located in your MB-700 module.
- Next download the configuration. Click at *Fieldbus1* or at *Bridge* (MB-700) with the right button of the mouse and select *Download*. The configuration will be sent to the MB-700.
- After having sent the configuration user must change the parameter ON_APPLY of the CCCF block to "Apply". This will update the configuration of the CCSM block.

On Line Configuration

It is possible to set blocks of the MB-700 on line with the device connected to the network and functioning. It is only necessary that user clicks over the block with right button of the mouse and select *On Line Characterization*. User may also monitor all parameters now.

IMPORTANT

To make effective the new configuration, user must always change the parameter ON_APPLY to Apply, otherwise this configuration will not be updated in the MB-700. User also must check which parameters may be set and changed in the "Auto" mode because a few parameters may only be changed in the OOS mode.

MB-700 as a TCP/IP Master

Description

MB-700 functionality in this scenario:

- Bypass (Serial to TCP): MB-700 works as protocol converter. In this function it converts a serial MODBUS RTU message to TCP/IP and TCP/IP to Modbus RTU.
- Peer-to-peer: MB-700 can exchange data between slave modbus devices. These slave devices might be in different Modbus networks and even they can change data between each other.

1 - MB-700 working as Bypass (Serial to TCP)

In this scenario MB-700 does not have concentrator functionality. Thus the only two blocks required to be set are CCCF and RESOURCE. Several MB-700s are connected in an Ethernet. In every MB-700 are connected several slave devices. User may set any of these controllers from the same station. Two MB-700 are connected and the respective stations are connected through the serial EIA-232 ports of each MB-700. The Ethernet ports connect these MB-700s to the corporate network. Connected to this network is a third MB-700 and on it are connected the slave MODBUS devices. MB-700 acts as a TCP/IP master establishing a bridge between workstations, local network and MODBUS network. The great advantage given by this configuration is to allow the connection of a MODBUS slave with several serial masters. This allows one slave to be accessible in several points of Ethernet through MB-700.

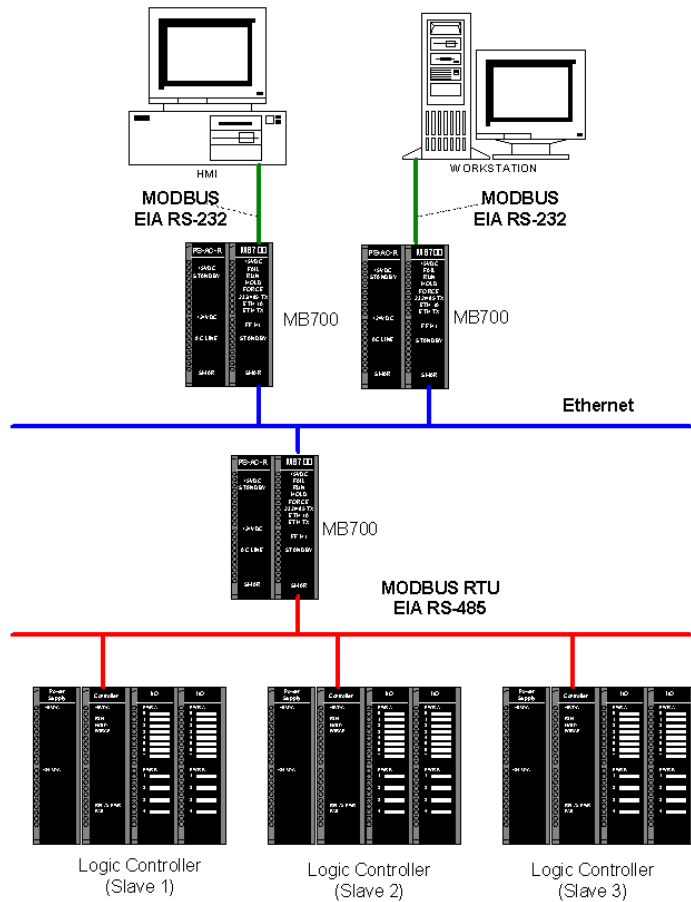

Fig. 5.14 – MB-700 working as Bypass Serial To TCP

Configuration

The RESOURCE block must have its parameter MODE_BLK put in “auto”.

The procedures to configure the CCCF block are similar to the previous application, except by the BYPASS_DIRECTION parameter now selected to “Serial to TCP”.

The parameter SLAVE_ADDRESS of the CCCF block must contain the IP address of the TCP slave(s) and its respective Modbus addresses.

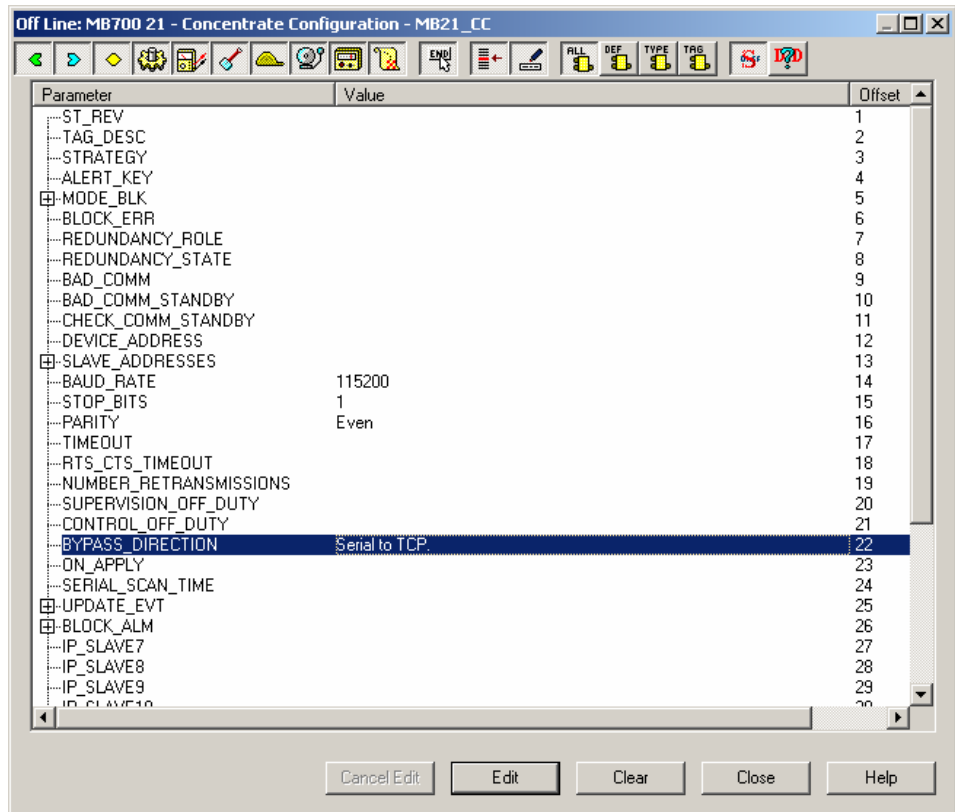

The configuration of the Modbus Slaves in the CCCF block follows the steps below

- If the configuration has only one a Modbus slave for a determined IP address, the parameter SLAVE_ADDRESSES must be used. In this case, for each IP_SLAVE it has a corresponding MODBUS_ADDRESS_SLAVE.

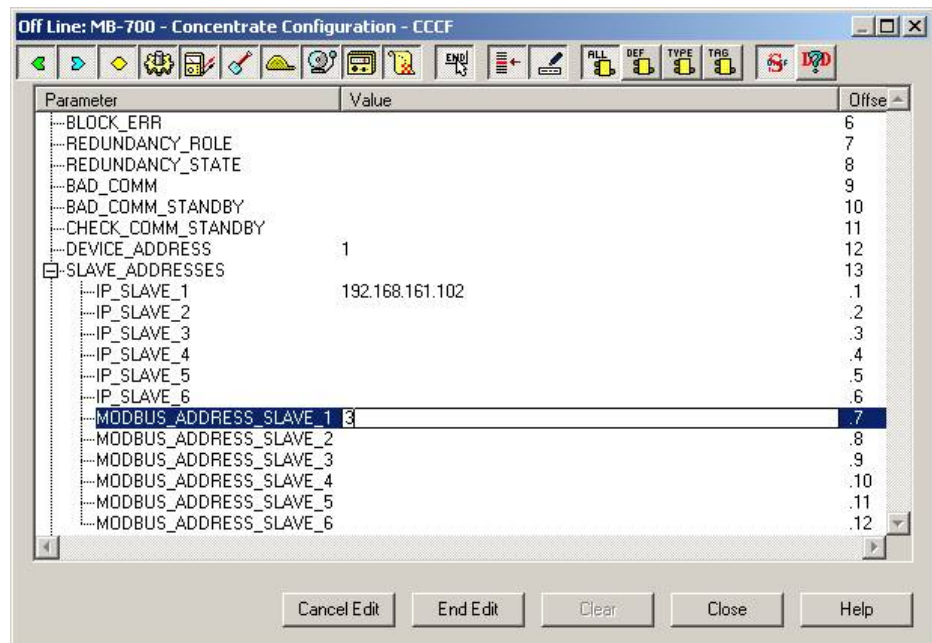

- If the configuration has more than one Modbus slave for the same IP address, the IP_SLAVE_x and DEVICE_IDS_IP_x parameters can be used. In this case, for each IP_SLAVE it can configure up to 32 Modbus slave addresses.

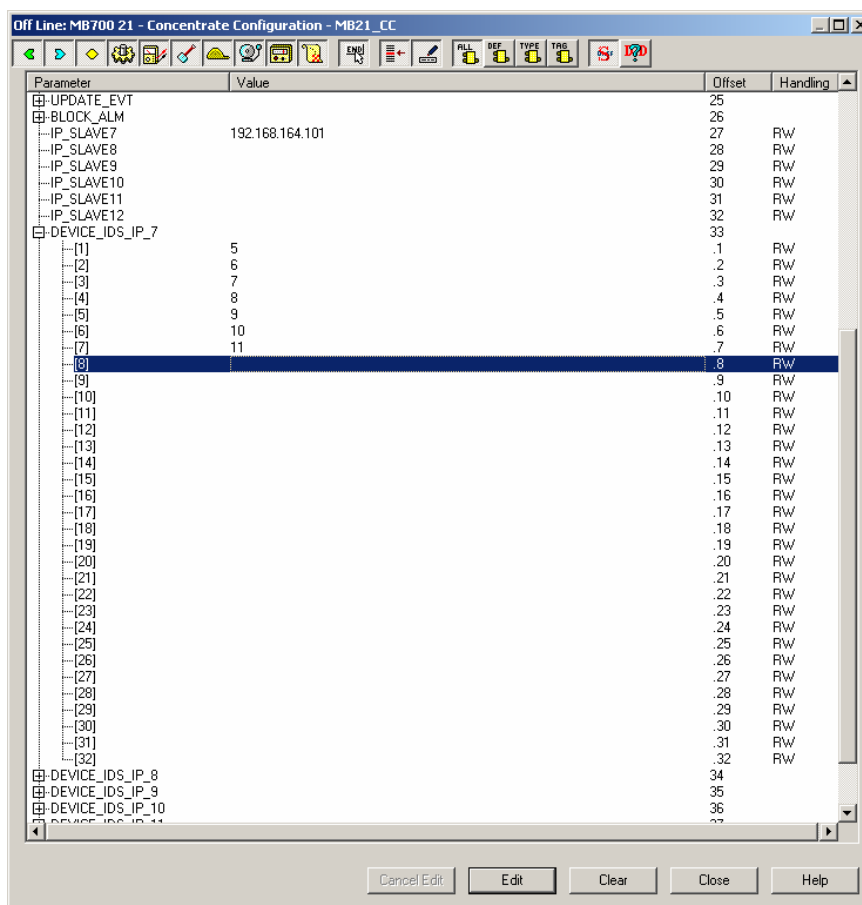

In the CCCF blocks change ON_APPLY to “Apply”.

Hit the ON button to start communication.



Next download the configuration. After this step has been done communication is established and the MB-700 is On Line.

2) MB-700 working as Peer-to-peer

For the MB-700 works as Peer-to-peer in the TCP/IP, the user must follow the defined steps for the Off Line Configuration in the item MB-700 working as Serial Peer-to-peer, and, besides this, the following parameters must be configured:

- In the CCCF block, the SLAVE_ADDRESSES and/or IP_SLAVE parameter must be configured with the IP and the Modbus address of the TCP/IP slaves (as described previously) up to the limit of 12 TCP/IP addresses.
- In the CCCM block, the EU_ADDRESS_XXXX.PORT_NUMBER parameter, select “Ethernet” indicating for this point (XXXX) the communication will be done through the TCP/IP. (Where XXXX can be IN_1...IN_4, IN_D1...IN_D4, OUT_1...OUT_4, OUT_D1...OUT_D4).

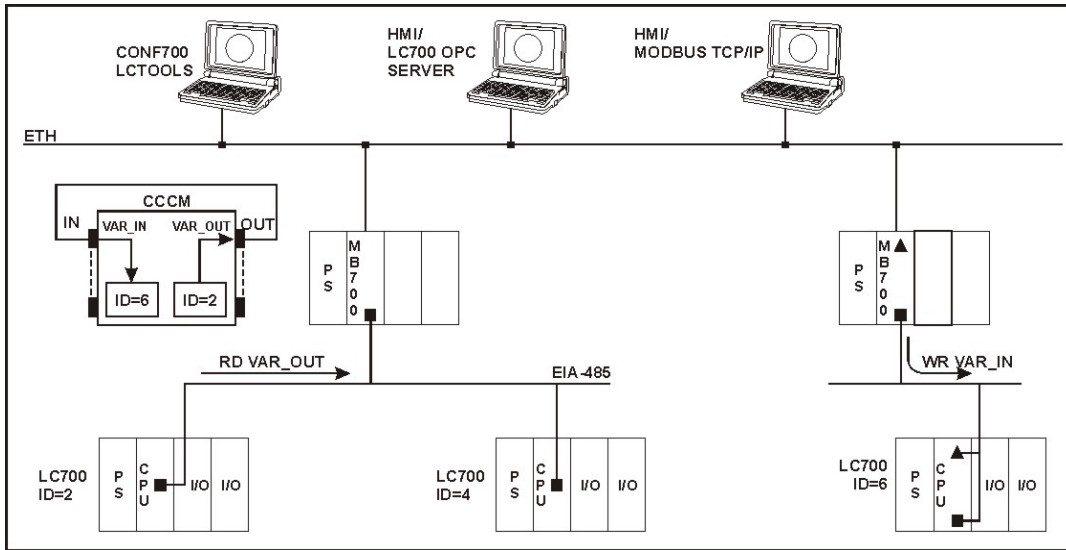

Fig. 5.3 – MB-700 working as Peer-To-Peer in the Serial and TCP/IP

MB-700 as a TCP/IP Modbus Slave

MB-700 working as Concentrator

The MB-700 module would operate as a Serial/TCP Modbus concentrator and can also work as TCP Slave of the Concentrated Dynamic Data into its CCSM block.

The Device Slave Address (ID Modbus) is defined in the DEVICE_ADDRESS parameter of the Concentrate Configuration block (CCCF).

The Modbus address of the parameter to be monitored is fixed for each CCSM block and depends on the block instantiation (it is indicated in the STRATEGY parameter).

To attend the redundancy, the MB block must answer like Slave Modbus as Active and also as Standby.

Modbus Address Calculation

Each block has a fixed range of Modbus Addresses, which is defined following the form:

$$\text{Modbus_Addr} = \text{Modbus_start_addr} + (\text{offset} * n)$$

Where:

n –STRATEGY parameter of the CCSM block (indicate the block instantiation)

For example, suppose the following configuration:

- MB-700
- CCSM1
- CCSM2
- CCSM3
- CCSM4

The Modbus Address of the BVALUE[1] parameter of the CCSM4 block would be:

$$\begin{aligned} \text{Modbus_start_addr} - \text{BVALUE}[1] &= 1001 \\ \text{CCSM block Offset} &= 200 \\ \text{CCSM.Strategy} &= 3 \text{ (fourth SM block in the configuration)} \\ \text{Modbus_Addr} &= 1001 + (200 * 3) \\ \text{Modbus_Addr} &= 1601 \end{aligned}$$

CCSM Block

Index	Parameter	Data Type	Modbus Address (Strategy = x) Offset_SM = 200 * x x = 0 ~ 24	Modbus Address Strategy= 0 Offset_sm = 0	Modbus Address Strategy= 1 Offset_Sm = 200	Modbus Address Strategy = 2 Offset_Sm = 400
10	SCAN_STATUS	UInteger16	42001 + Offset_SM	42001	42201	42401
11.1	BVALUE[1]	Bool	2001 + Offset_SM	2001	2201	2401
11.2	BVALUE[2]	Bool	2002 + Offset_SM	2002	2202	2402
11.96	BVALUE[96]	Bool	2096 + Offset_SM	2096	2296	2496
12.1	IVALUE[1]	Integer32	42002-42003 + Offset_SM	42002-42003	42202-42203	42402-42403
12.2	IVALUE[2]	Integer32	42004-42005 + Offset_SM	42004-42005	42204-42205	42404-42405
12.8	IVALUE[8]	Integer32	42016-42017 + Offset_SM	42016-42017	42216-42217	42416-42417
13.1	P_EU_VALUE_A[1]	Float	42018-42019 + Offset_SM	42018-42019	42218-42219	42418-42419
13.2	P_EU_VALUE_A[2]	Float	42020-42021 + Offset_SM	42020-42021	42220-42221	42420-42421
13.28	P_EU_VALUE_A[28]	Float	42072-42073 + Offset_SM	42072-42073	42272-42273	42472-42473
14.1	P_EU_VALUE_B[1]	Float	42074-42075 + Offset_SM	42074-42075	42274-42275	42474-42475
14.2	P_EU_VALUE_B[2]	Float	42076-42077 + Offset_SM	42076-42077	42276-42277	42476-42477
14.28	P_EU_VALUE_B[28]	Float	42128-42129 + Offset_SM	42128-42129	42328-42329	42528-42529
15.1	FVALUE[1]	Float	42130-42131 + Offset_SM	42130-42131	42330-42331	42530-42531
15.2	FVALUE[2]	Float	42132-42133 + Offset_SM	42132-42133	42332-42333	42532-42533
15.16	FVALUE[16]	Float	42160-42161 + Offset_SM	42160-42161	42360-42361	42560-42161

Using the Data Logger

Description

The MB-700 may store data logs from a LC700 data logger block (FIFO). So, during normal reading of the Concentrate Data Logger it checks if there are data stored in the correspondent slave. In case there are data stored it will read these data and clear the log buffer of the slave.

Configuration

First create a FIFO block in the LC700. In the SYSCON configuration it is possible to include as many Concentrate Data Logger blocks as it is required. To insert a CCDL block just proceed like it was done to the other MB-700 blocks.

NOTE: the amount of CCDL blocks depends on the FIFO size defined in the LC700 (FIFO Size). Each CCDL supports up to 280 data samples. For example, if the FIFO size is 1000 registers and the data type is integer (percentage) so it is necessary: $1000/280 = 4$ CCDL blocks.

In case the data type is REAL, using the same 1000 registers and knowing that one REAL value requires 2 registers for each sample so the calculation becomes: $500/280 = 2$ CCDL blocks. The CCDL block works together with the supervision blocks. Thus there must be supervision blocks pointing to the same address of the slave so that the CCDL block works properly.

An example of configuration is shown below. Consider a configuration where the LC700 has the following settings:

- SLAVE_ADDR = 1 (LC700 Address)
- STOP_SCAN_ADDRESS = 2009 (FIFO_LOAD)
- CLEAR_LOG_ADDRESS = 2011 (FIFO_CLEAR)
- LOGGER_ADDRESS = 42506 (FIFO_CTW)
- NEED_SCAN_ADDRESS = 2 (FIFO_EMPTY)
- DATATYPE BLOCO FIFO = REAL

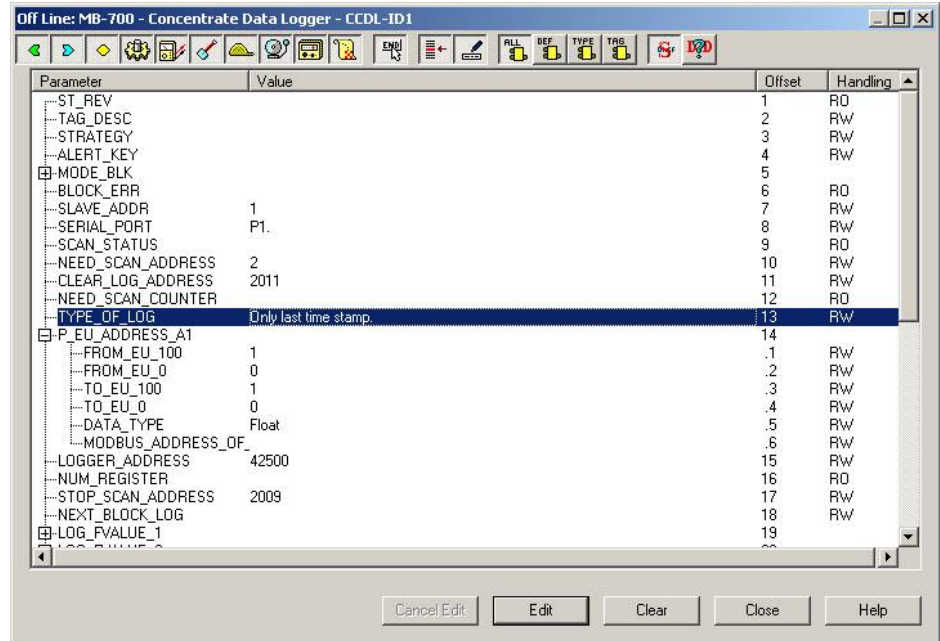

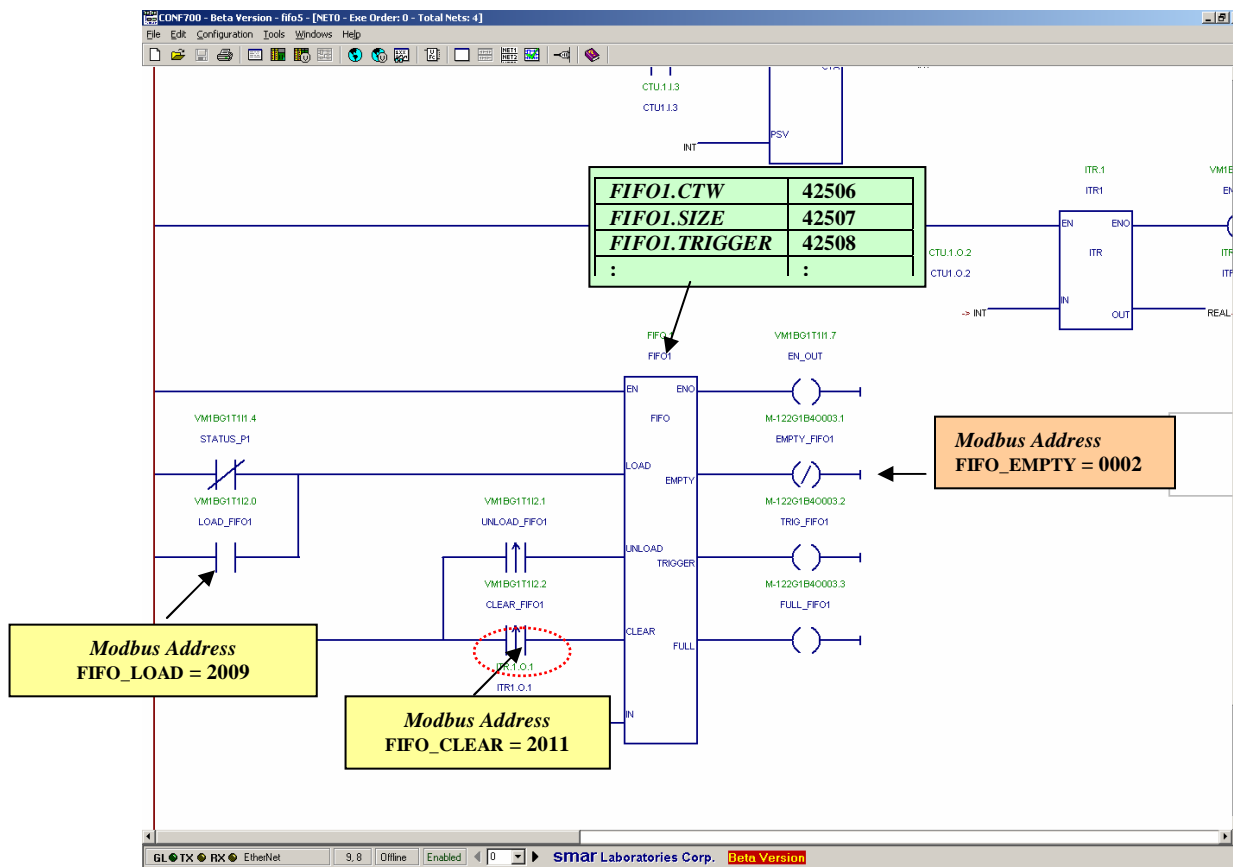

Putting CCDL blocks in cascade

In case the amount of stored data is bigger than it is supported by the CCDL block user might put CCDL blocks in cascade, it is only necessary to repeat the same configuration to all the data logger blocks. In this way, the MB-700 will start to use blocks according to the order of instantiation indicating which is the next block stored through the parameter NEXT_BLOCK_LOG.

Block Minimum Configuration Table for the MB-700

Function	Necessary Blocks	Number of Points supported by Block
BYPASS	RESOURCE CCCF	
CONCENTRATOR	RESOURCE CCCF CCSM1 : : CCSM25 (Support up to 25 Blocks SM)	1 CCSM = 96 DISCRETE POINTS 08 INTEGER POINTS 56 PERCENTAGE 16 FLOAT
PEER-TO-PEER in the Serial , ETHERNET or BOTH	RESOURCE CCCF CCCM1 : : CCCM16 (Support up to 16 Blocks CM)	1 CCCM = 04 ANALOGIC POINTS 04 DISCRETE POINTS

Observation: The MB-700 support Mixed function like Bypass and Concentrator and Peer-To-Peer.

Chapter 6

SCENARIOS

The following scenarios presented here use the Smar's LC700 as an example of MODBUS RTU slave device, however, the MB-700 may be used with any MODBUS RTU slave device.

Multiple masters TCP/IP communicating directly with several LC700s, including via Radio

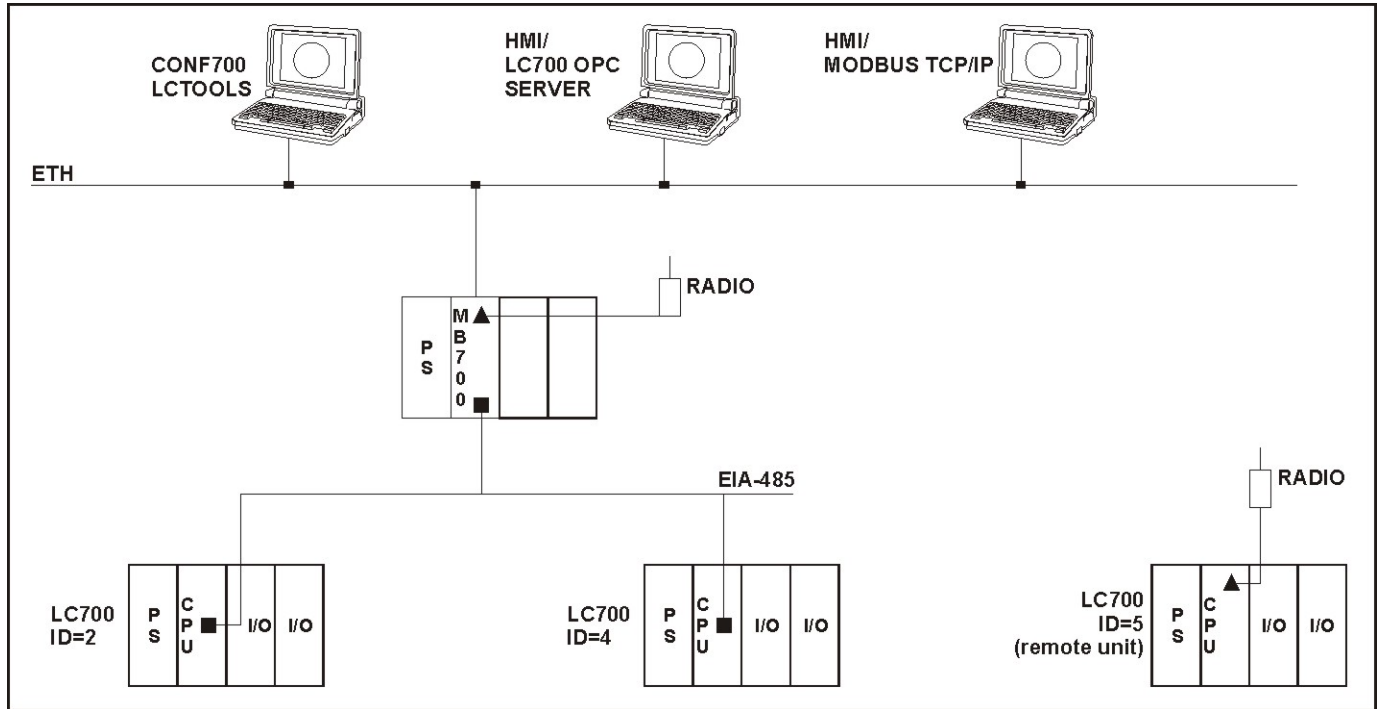

In this application, the MB-700 supports the following simultaneous functionality:

- ✓ CONF700 downloads/uploads via TCP/IP including remotely.
- ✓ Supervision of the LC700 via OPC and/or Modbus TCP/IP driver.
- ✓ Firmware download of the LC700 via TCP/IP including remotely.

The MB-700 is connected to the corporate network through its Ethernet port. In the network is connected the workstation to configuration and monitoring of the slave devices. Serial ports EIA-232 and EIA-485 allow 3 LC700 to be connected to the MB-700. Two of the controllers are connected through the EIA-485 bus and a third one is connected through a radio link. This last one is a remote unit because its physical location is far from the MB-700 master. The first LC700 has Modbus ID=2 and the second ID= 4 and the remote LC700 has ID= 5.

The MB-700 has an IP address within the Ethernet. So the configuration and supervision tools might "see" the MB-700 in this network. In the CCCF block communication parameters are set, like timeout, baud rate, bypass direction (TCP to Serial), parity and number of retransmissions.

Multiple masters TCP/IP communicating directly with several LC700s and "peer-to-peer" between LC700s within a same Modbus RTU network

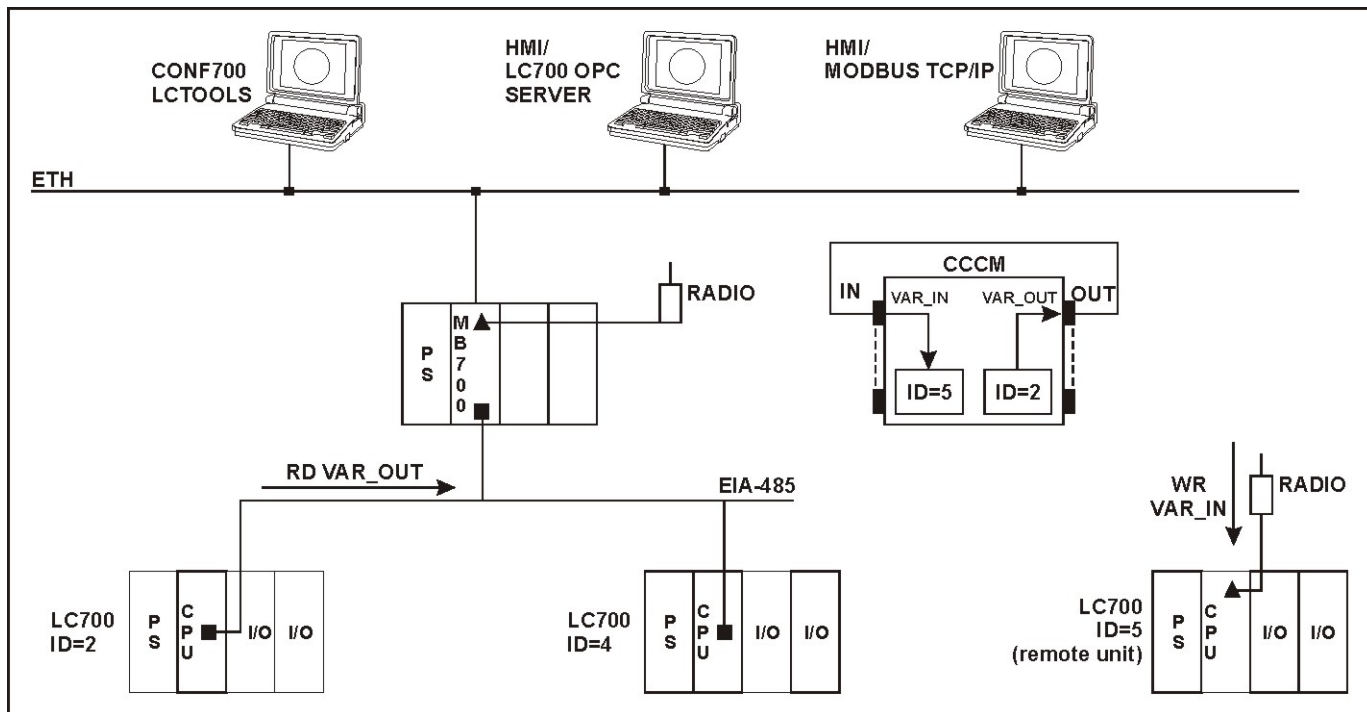

In this application, the MB-700 supports the following simultaneous functionality:

- ✓ CONF700 downloads/uploads via TCP/IP including remotely.
- ✓ Supervision of the LC700 via OPC and/or driver Modbus TCP/IP.
- ✓ Firmware download of the LC700 via TCP/IP including remotely.
- ✓ "Peer-to-peer" communication between LC700s within a same Modbus RTU network, including remote units (From LC700 ID=2 to the LC700 ID= 5).

This scenario is similar to the previous ones, however the peer-to-peer function was implemented. There is peer-to-peer communication between LC700s of the same network, including remote units. For example from LC700 (ID=2) to LC700(ID=5).

This functionality is added through the CCCM block. In this block the parameter PORT_NUMBER is set. Communication between slaves is made through the serial ports EIA-232 and EIA-485 (port P1 of the MB-700)

Communication peer-to-peer between LC700s with MODBUS IDs 2 and 5, respectively, requires a CCCM block. This block will inform the MODBUS address of the variables that must be read and the addresses where these variables will be written. Communication is made within the MODBUS RTU network in a EIA-232 and EIA-485 (radio link) serial physical means.

Thus, slaves may change data directly from each other, without it is necessary the message passing through the TCP/IP masters. The MB-700 allows it connecting two points of the MODBUS network. Within each CCCM block up to 8 peer-to-peer links may be established, because it has 4 digital inputs/outputs and 4 analog inputs/outputs.

Multiple masters TCP/IP communicating directly with several LC700s and “peer-to-peer” between LC700’s of different Modbus RTU networks

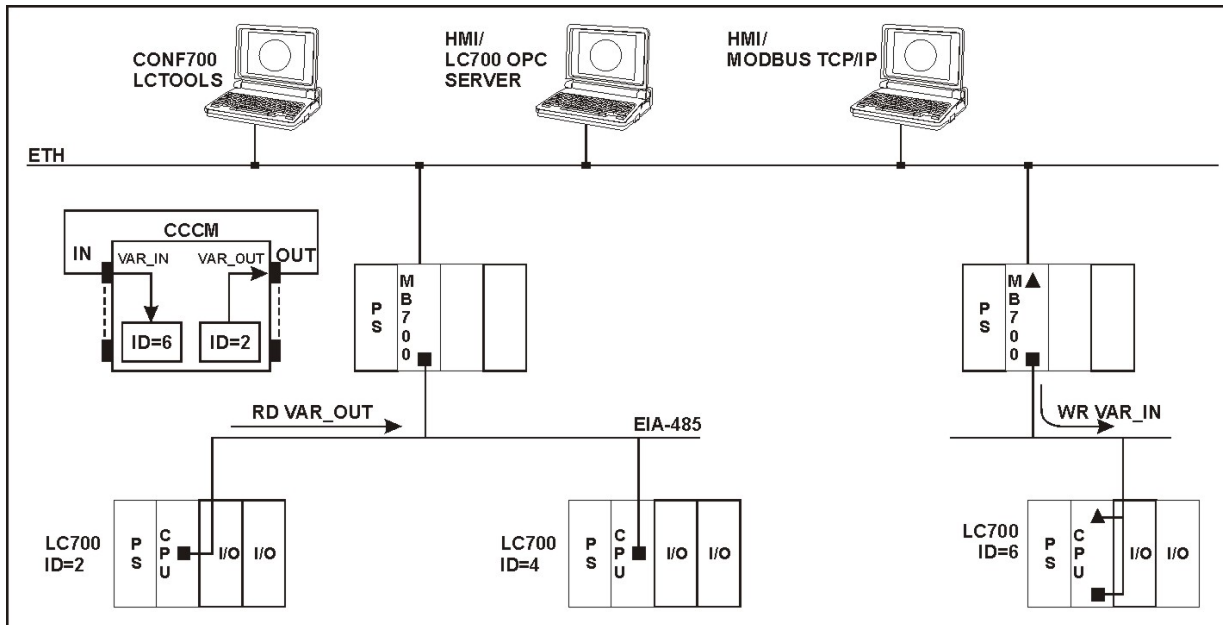

In this application, the MB-700 supports the following simultaneous functionality

- ✓ CONF700 downloads/uploads via TCP/IP including remotely.
- ✓ Supervision of the LC700 via OPC and/or driver Modbus TCP/IP.
- ✓ Firmware download of the LC700 via TCP/IP including remotely.
- ✓ “peer-to-peer” Communication between LC700 of different Modbus RTU Networks (from LC700 ID=2 to LC700 ID=6)

Differently from previous scenarios, there is a second (actually more than 2 would be possible) MB-700 connected to the Ethernet. Peer-to-peer communication is established between slave ID=2 and slave ID= 6. As both are connected in two different MODBUS RTU networks, two MB-700s are connected to these slaves to the Ethernet. The MB-700 where it is connected the slave ID=2 has an IP address. Similarly the second MB-700 also has an IP address. Only one CCCF is necessary to make the peer-to-peer communication.

Each MB-700 must have a CCCF block set to establish communication parameters. The bypass still is made in the “TCP to serial” direction. In the scenario the CCCF block has a major role in addressing inside Ethernet and MODBUS RTU networks. In the parameter SLAVE_ADDRESSE is informed the IP address of each MB-700, in the field IP_SLAVE1 and in the field IP_SLAVE2. Each of these has a correspondent MODBUS_ADDRESS_SLAVE where are informed the IDs of each MODBUS RTU slave. The address where it is read the variable has the configuration shown below:

The variable is read from the address:

IP of the first MB-700	Modbus ID of slave (LC700)	Modbus address of the variable
192.168.164.101	02	30001

The variable is written at:

IP of the second MB-700	Modbus ID of slave (LC700).	Modbus Address
192.168.164.102	06	40001

Multiple masters TCP/IP communicating directly with LC700s, "peer-to-peer" and network redundancy

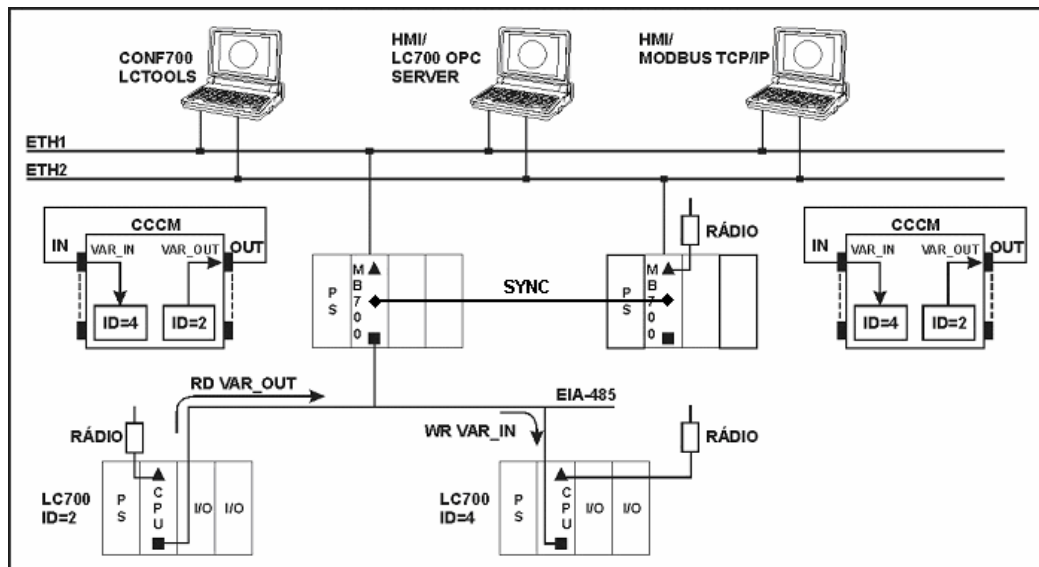

In this application, the MB-700 supports the following simultaneous functionality

- ✓ CONF700 downloads/uploads via TCP/IP including remotely.
- ✓ Supervision of the LC700 via OPC and/or driver Modbus TCP/IP.
- ✓ Firmware download of the LC700 via TCP/IP including remotely.
- ✓ "Peer-to-peer" communication between LC700s (From LC700 ID=2 to the LC700 ID= 5).
- ✓ Communication network redundancy between multiple TCP/IP masters and LC700s, inclusively through different physical means (EIA-485 and radio)

Network redundancy allows (in case of failure in the main network) the MB-700 to assume supervision and control of communication between masters TCP/IP and Modbus RTU slaves. The first MB-700 connects TCP/IP masters to the MODBUS slaves through Ethernet ETH1 and its serial channel EIA-485. The second MB-700 connects TCP/IP masters through the redundant Ethernet ETH2 and the serial EIA-232 channel where it is connected a radio link between MB-700 and the slave CPUs.

MB-700 as a concentrator and supervision via DFI OPC Server

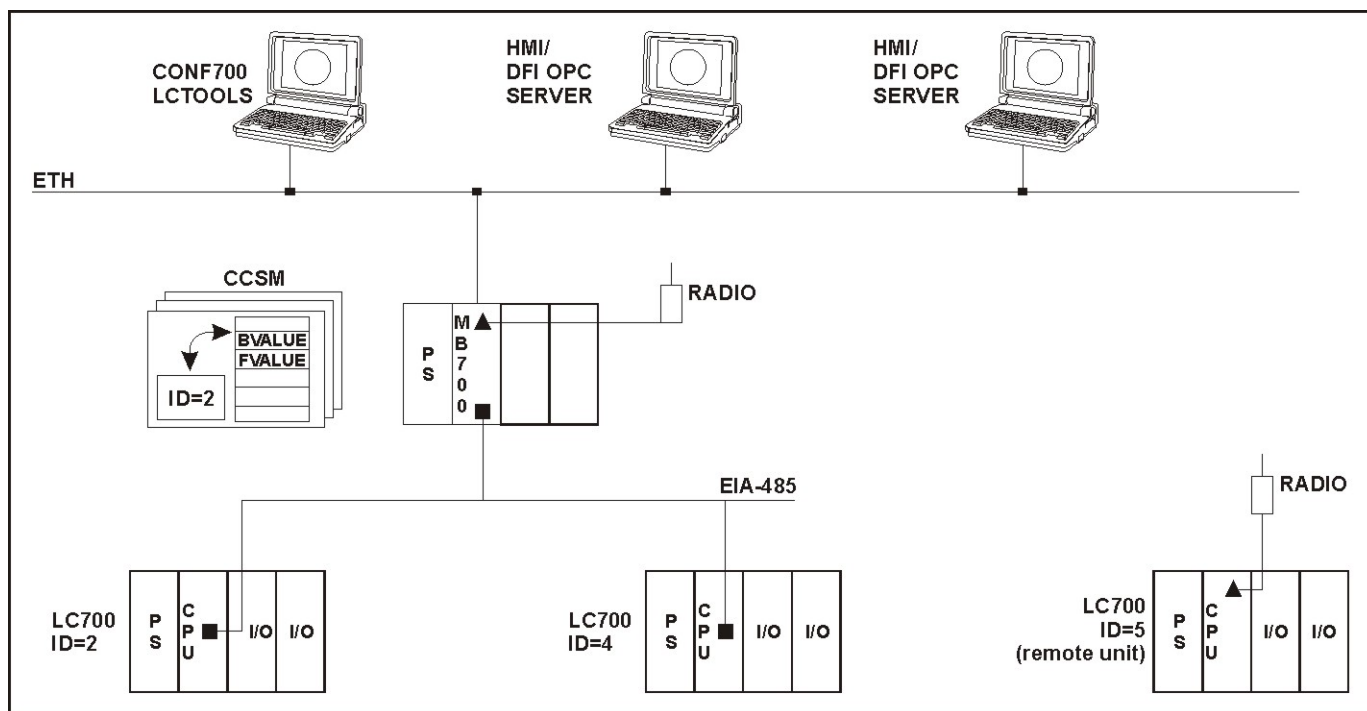

In this application, the MB-700 supports the following simultaneous functionality:

- ✓ CONF700 downloads/uploads via TCP/IP including remotely.
- ✓ Firmware download of the LC700 via TCP/IP including remotely
- ✓ Supervision of the LC700's indirectly through MB-700, that is, via DFI OPC server monitoring parameters of the CCSM block that are copies of the Modbus variables from the LC700s.
- ✓ Possibility to have multiple DFI OPC Servers or working with only one OPC server accessed remotely. Clients access parameters of the CCSM block.

Configuring the CCSM block allows Modbus variables to be read and copied inside the MB-700 memory. For each LC700 there is only one CCSM block. In the CCSM block it is informed the LC700 ID (ID=2 above) and the MB-700 scans the Modbus variables set within the CCSM block and registers them inside its memory as a parameter of the CCSM block. Through the DFI OPC Server these variables are read from an OPC client. In this way when user monitors one variable, the access is faster, because the MB-700 stores this value in its memory in the parameter sheet of the CCSM block.

MB-700 working as a concentrator and supervision via DFI OPC server and "peer-to-peer"

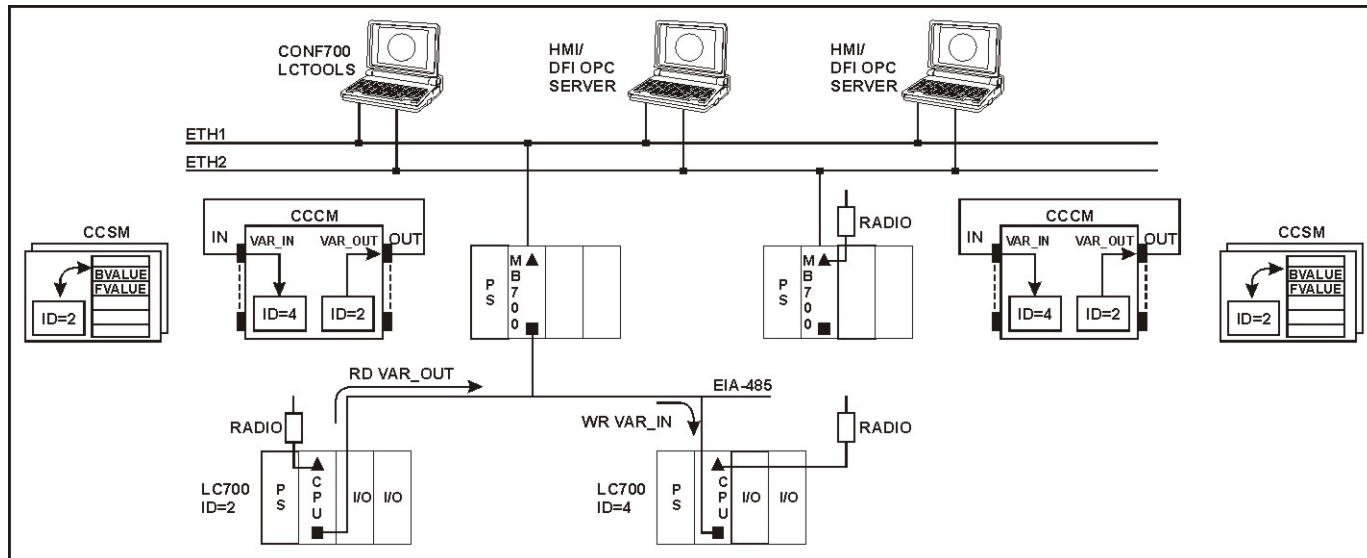

In this application, the MB-700 supports the following simultaneous functionality:

- ✓ CONF700 downloads/uploads via TCP/IP including remotely.
- ✓ Firmware download for the LC700 via TCP/IP including remotely.
- ✓ Supervision of the LC700's indirectly through MB-700, i.e., via DFI OPC server monitoring parameters of the CCSM block that are copies of the Modbus variables from the LC700s.
- ✓ Possibility to have multiple DFI OPC Servers or working with only one OPC server accessed remotely. Client access parameters of the CCSM block.
- ✓ Peer-to-peer communication between LC700s of different MODBUS RTU networks (from LC700 ID=2 to LC700 ID=6)

MB-700 as concentrator, supervision via DFI OPC Server, "Peer-to-peer" and network redundancy

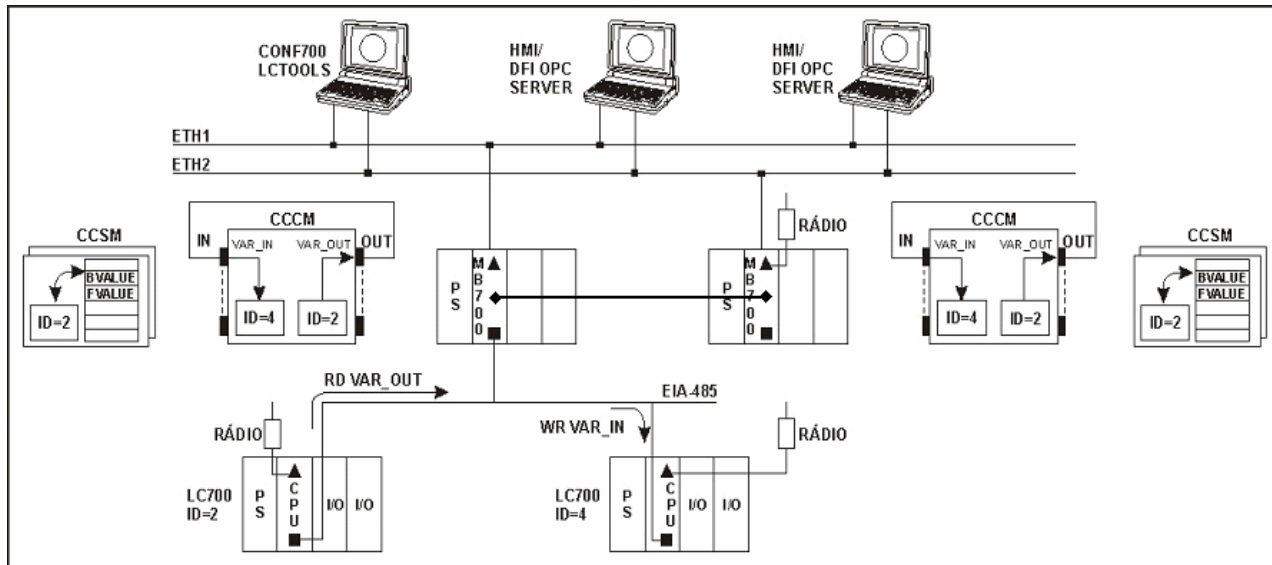

In this application, the MB-700 supports the following simultaneous functionality:

- ✓ CONF700 downloads/uploads via TCP/IP including remotely.
- ✓ Firmware download for the LC700 via TCP/IP including remotely.
- ✓ Supervision of the LC700's indirectly through MB-700, that is, via DFI OPC server monitoring parameters of the CCSM block that are copies of the Modbus variables from the LC700s.
- ✓ Possibility to have multiple DFI OPC Servers or working with only one OPC server accessed remotely. Client access parameters of the CCSM block.
- ✓ Peer-to-peer communication between LC700s of different MODBUS RTU networks (from LC700 ID=2 to LC700 ID=6)
- ✓ Network communication redundancy between masters TCP/IP (CONF700 and LC700Tools) and DFI OPC Server (supervision) with the LC700s, including different physical means (EIA-485 and radio link).

Multiple MODBUS RTU masters accessing a LC700 through only one port (P2)

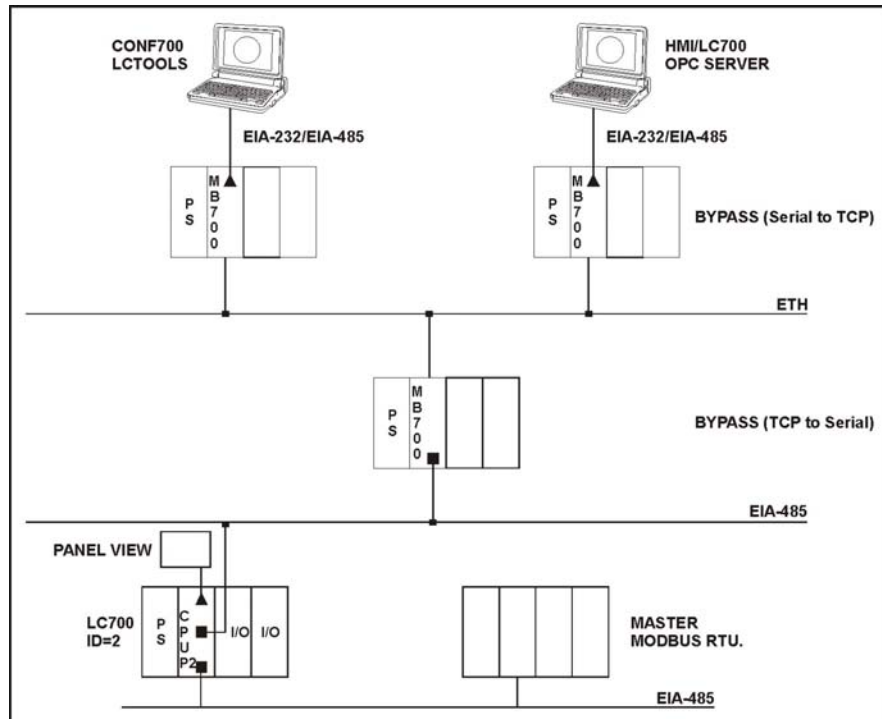

In this application, the MB-700 supports the following simultaneous functionality:

- ✓ The multi-master functionality is obtained in the MODBUS RTU.
- ✓ Two MB-700 performing bypass (Serial to TCP).
- ✓ One MB-700 performing bypass (TCP to serial).

In the above scenario MODBUS RTU masters (CONF700, LC700Tools, LC700 OPC Sever) are connected each one to one MB-700 through the serial EIA-485 channel. Each of these MB-700s connects to one point of the Ethernet. In this Ethernet it is connected a MB-700 whose EIA-485 channel forms a bus of MODBUS RTU network. In this network, connect the LC700. In the port P2 of this device, a master MODBUS RTU is connected through the serial channel EIA-485.

REDUNDANCY HOT STANDBY

Complete Redundant System Architecture

The redundant system, below, shows different functionalities with redundancy, as it will be seen below.

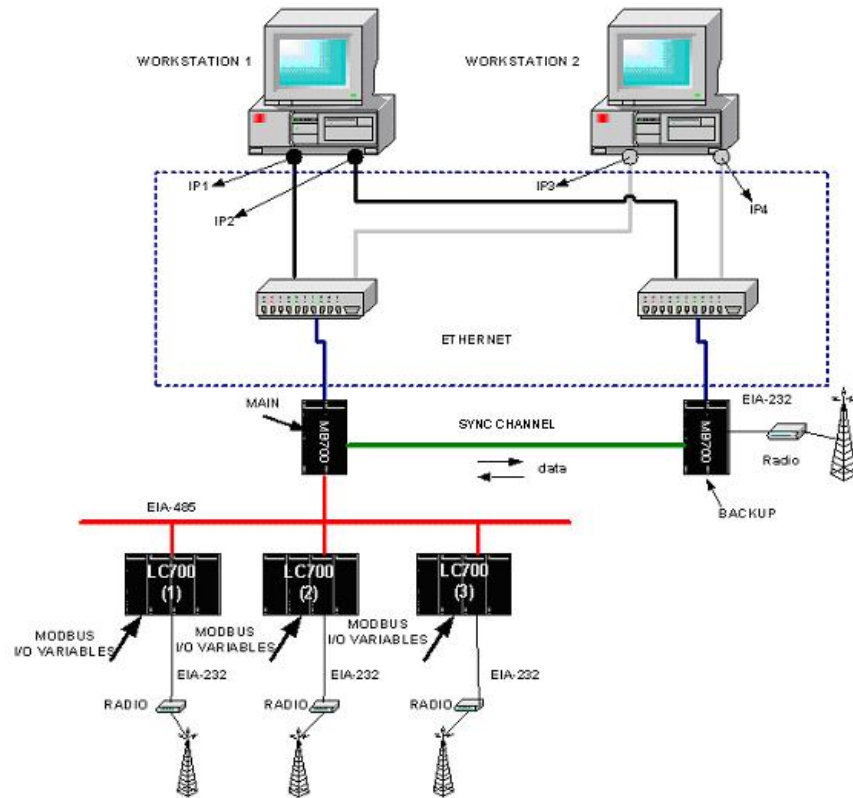

The functionalities with redundancy are:

- Supervision Workstations: The application shows two supervision workstations, which can monitor variables/tags of the MB-700 module.
- Ethernet Network: Each supervision station has two boards, each one in an Ethernet network, using different switches. Thus, even if there was trouble with one board or net cable, or a supervision station switch, it will stay in conditions to keep the supervision, beyond to be available the other supervision station.
- Redundant Source and Backplane: Each MB-700 has its source and backplane and, although the application above does not show, it already is possible to do power supply redundancy for each MB-700.
- Redundancy of the MB-700 module: How the MB-700 module is responsible for all store and control of the information interchange between Modbus slaves, the redundancy of this module assures the availability of the supervision and control system functioning without interruption.
- Diagnosis: Through the MB-700 transducer parameter monitoring can be tracking the possible failures which are on the system.

MB-700 Module Redundancy

Terminology

Role: User configuration which defines the module as Main or Backup;

State: Module state which depends on the conditions that both are, and also the Role configuration. The possible states are Active and Standby;

Active: State which indicates basically if the module is executing the function blocks, which will be responsible for the Scan of the net and data update.

Standby: State which the MB-700 monitors the manner and the performance of the other block, for an eventual necessity to be as Active. It keeps constantly updated with regard to processed data for Active, through the redundant communication channel;

Main: It is an user configuration which defines which module must be preferentially Active. Thus, if both MB-700's are in good conditions to execute the function blocks (including the Modbus communication), the configured module as Main will be the Active module;

Backup: It is an user configuration which defines which module must pass the control to the other when they are in the same operation conditions. And will must assume as Active when occurs fail in the other MB-700 module;

Hot Standby: Redundancy schematic where it has an active element and other constantly alert monitoring the active condition, maintaining constantly updated in order to assume the control from the last condition;

Local: It is the MB-700 module with which it is communicating and supervising. Remember that the MB-700 Standby module can be supervised, that is, the MB-700 standby block parameters which are copies of the MB-700 Active block parameters, can be monitored;

Remote: Almost all MB-700 Active data base is transferred to the MB-700Standby, but some information does not fit in this case, for example, the redundancy configuration (Role) and the state. Through the IDShell Transducer Block it is possible to know not only the MB-700 (Role) configuration and the State, which is being supervising (Local), but also the other MB-700 (Remote), because this information is exchange between both by the redundancy communication channel;

Communication channel for redundancy: It is the communication channel between the MB-700modules in order to synchronize both, that is, the configuration of both is always equal and the process dynamic variables are constantly transferred;

Switchover: Control switching from one module to other, that is, a MB-700 which is Standby becomes to Active.

System Pre-requirements

The requirements listed here apply to both redundancy modes.

The version of firmware for redundant systems has the termination "R". It indicates a firmware suitable for redundant applications. With the redundant firmware, the module initializes by default in Hot Standby mode, in a safety state called "Sync_Idle". The user as will be seen forth can change the redundancy mode later, if necessary.

The SYSCON configuration should be created as it is usually done for a non-redundant system (in case of questions, please refer to Chapter 3 of this manual). The unique difference (now that redundancy is involved) is that it is necessary to add a transducer function block to the bridge. This transducer will be used then to initialize the redundancy.

In the SYSCON configuration, the tag for the transducer block can be any, preferentially a meaningful tag concerned to the MB-700 tag or to the plant. Be careful to not use tags already in use in the same plant.

Further information on SYSCON operation, can be found in its own manual.

For any of the redundancy modes it is necessary first of all to configure the network redundancy. The next section explains how to do it.

Configuring the Network Redundancy

In order all the OPC-Client tools be able to deal with network redundancy it is necessary configure the workstation and the DFI OLE Server.

Configuring the workstation

It is possible to have one or two workstation (redundancy of workstation). Here follows the steps for the configuration.

- 1 - Each workstation must have an HMI installed.
- 2 - Each workstation must have installed two NICs (Network Interface Card).
- 3 - Each NIC must be configured in a different subnet range (e.g. NIC1, IP=**192.168.164.50** / Subnet Mask 255.255.255.0 and NIC2, IP=**192.168.163.50** / Subnet Mask 255.255.255.0).
- 4 - Configure also the default gateway according to your specific needs.
- 5 - Install two HUBs or switches. Each NIC must be connected to one of them in such a way that two LAN are assembled isolated from each other.
- 6 - That way, each one of the MB-700 modules can be connected to one of the HUBs obeying the subnet ranges predefined (e.g. First MB-700, IP=**192.168.164.51** / Subnet Mask 255.255.255.0 and Second MB-700, IP=**192.168.163.51** / Subnet Mask 255.255.255.0).
- 7 - To test the network configuration, a *ping* command to each one of the MB-700 modules can confirm if everything is working fine.

Configuring the DFI OLE Server

There are two ways to configure the OLE Server for network redundancy: Here follows the steps for the configuration in each case.

The HMI Client chooses the DFI OLE Server (local and remote).

In this case, the local Server has a specific NIC adapter and the Client chooses what server will be used.

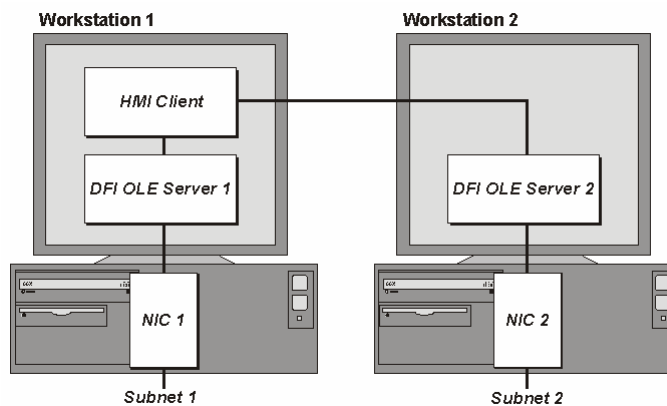

- 1 - Configure in the file SmarOleServer.ini, the NIC adapter that will be used on each workstation ports (e.g. First workstation, NIC=192.168.164.50 and Second workstation, NIC=192.168.163.50).
- 2 - Doing so, each DFI OLE Server will choose the specified NIC adapter.
- 3 - When configuring the HMI, configure each TAG to be monitored using two possible ways: First one, using Local DFI OLE Server, second option, using Remote DFI OLE Server (some HMI does not permit this kind of configuration and you will need to use an external software).

4 - To validate the Remote connection between Client and Server, make sure to configure DCOM and NT Security. The steps are described in the Appendix A in this manual.

The DFI OLE Server is connected to both subnets where are located the redundant modules. In this case, the client uses only one server that will choose which NIC adapter is to be used.

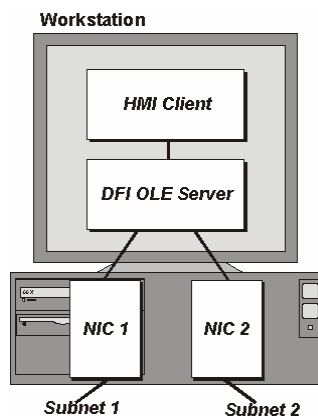

1 - Configure in the file SmarOleServer.ini the NIC adapters as intended. Example:

NIC = 192.168.164.50

NIC2 = 192.168.163.50

2 - Doing so, the DFI OLE Server will have information through both the NIC adapters.

The last updated good data will be chosen by the DFI OLE Server to be forwarded to the client. When the MB-700 is in Hot Standby mode, the DFI OLE Server will preferably choose the data that came from the *Active* module, to be forwarded to the client.

Configuring Hot Standby Redundancy

In order to enable the Hot Standby redundancy and monitor its status, some parameters available in the MB-700 transducer block should be used.

Most redundancy parameters have a suffix. The suffix “L” means *Local*, or that the parameter brings information of the module that is being monitored directly through the DFI OLE Server. The suffix “R” means *Remote*, or that the parameter brings information that the *Local* module knows about the other module through the synchronization path

Here is presented a functional description of these parameters in order to understand how the Hot Standby redundancy works. For further information on these parameters see also the transducer block description table (FF Blocks manual at section 2.4).

FUNCTION_IDS

This is the unique parameter to be configured. The user must assign one module to be the *Main* setting Sync_Main. After that, through the synchronism path the other one automatically will be set as *Backup*. This designates physically who should be, in other words, the Preferential and the Redundant processor module respectively. This way, *Main* and *Backup* can be understood simply as labels.

- **RED_ROLE_L / RED_ROLE_R**

It reflects the configuration made at FUNCTION_IDS, identifying the *Role* of the module, Sync_Main or Sync_Backup.

- **RED_STATE_L / RED_STATE_R**

Active - runs all the tasks and generates all the data.

Standby – does not run the tasks, but just receives all the data generated by the other one and stands ready to assume, if necessary.

Not Ready – redundancy not available.

The different failures that may occur in such system, lead it to a *switch over*, when the *Standby* bumplessly becomes *Active* and vice-versa. The possible reasons for a *switch over*, divided in two types, are as follows:

General Failures

When the whole processor module fails, this comprises:

- Hardware failure
- Power off
- Removal of the processor module from the back plane.

Bad Condition Failures

When one of the processor module interfaces fails:

- Modbus communication failure (hardware or cable; in the case of operating as master).

The system is capable of checking which one has the best conditions, electing it as the *Active*.

It is certain the recovery of one failure at a time. That is, once a fail has occurred, a second fail will be recovered by redundancy just if the first fail has been fixed. While the failure is not fixed, the system has the redundancy not fully available (in case of *Bad Condition Failures*) or even not available (in case of *General Failures*).

For the case of *General Failures*, as soon as the failed module recovers a healthy state or is replaced, the modules automatically become a redundant pair again. That is, the system automatically recognizes a new inserted module.

- **RED_SYNC_STATUS_L / RED_SYNC_STATUS_R**

This parameter reflects all the possible status of the synchronism between the modules.

SYNC STATUS	DESCRIPTION
<i>Stand Alone</i>	There is just one module operating. If the system has been synchronized at least once, and this value appears, it indicates that the other module had a General Failure.
<i>Synchronizing</i>	The modules are checking their configuration with each other in order to reach the <i>Synchronized</i> status. It can take up to 9 min. at maximum when the system waits for the module in "Not Ready" state get its live lists completed.
<i>Updating Remote</i>	Just after the download of the configuration, the module transfers the whole configuration to the other one through the synchronism path.
<i>Maintenance</i>	The module is being configured by the other module through the synchronism path or by the SYSCON. If it appears for both "L" and "R" parameters it indicates that none of the modules have been configured.
<i>Synchronized</i>	The modules are in perfect synchronism. The <i>Active</i> continuously updates the <i>Standby</i> databases.
<i>Warning: Role Conflict</i>	If a spare module is connected in the panel with the same <i>Role</i> of that one is already running, this warning is shown. The procedure to fix this conflict is to perform a Factory Init in the spare module.
<i>Warning: Sync Cable Fail</i>	If a failure occurs in the synchronism cable, this warning is shown. The system will not have the redundancy until the synchronism cable is fixed.

SYNC STATUS	DESCRIPTION
<i>Warning: Updating Remote Fail</i>	If a failure occurs in the transfer of configuration from the <i>Active</i> to the <i>Standby</i> , this warning is shown. The procedure is to perform a <i>Factory Init</i> in the module that is not <i>Active</i> and wait until the transfer is completed successfully.

• **RED_BAD_CONDITIONS_L / RED_BAD_CONDITIONS_R**

It can present one or more value (concatenated) as follows:

BIT	BAD CONDITION	DESCRIPTION
0	Modbus	When working as master and if no Modbus slave device answers, it means that Modbus communication is in bad conditions. It can be caused by failures on the communication path or even a failure on the slave.

The desirable and most probable value is <none> for both modules (*L* and *R*), which assures good conditions for both, and therefore, redundancy fully available. This parameter can have two functions as follows:

- A *Bad Condition failure* for the *Active* module takes the system to a *switch over*. In this case, this parameter acts as record of the reason of the last *switch over*.
- When a *Bad Condition failure* occurs for the *Standby* module this parameter shows this condition as an alarm. Thus, warning the operator that the *Standby* presents a specific problem, it allows proactive maintenance in order to have redundancy fully available.

• **RED_MAIN_WDG / RED_BACKUP_WDG**

These are watchdogs that indicate the communication status between the HMI and the processor modules. While their values are incrementing within 2 seconds the respective network connections (*Main* and *Backup*) are working fine.

As a simple rule, the redundancy is fully available, ONLY if the modules are *Synchronized* and have <none> in *Bad Conditions* parameters (*L* and *R*).

The following operations can be performed without process interruption: replacing a module with failure, fixing the system when the cable breaks, firmware update, and adding redundancy to a system in operation.

NOTE
When the STAND BY LED is “on”, it means that the module is in <i>Standby</i> . When the LED is “off”, the module may be either in <i>Active</i> or <i>Not Ready</i> . If one of the modules is in <i>Standby</i> , the other is surely in <i>Active</i> .

Here follows the steps for the **Hot Standby Redundancy configuration and maintenance**. It is recommended that the steps are all read and understood before are executed.

First time configuration procedure

This is the procedure to configure the system with Hot Standby Redundancy for the first time, at the plant start-up.

- 1 - With the SYNC connector disconnected, execute a *Factory Init* in both modules in order to grant the default state.
- 2 - Connect both modules together, through the SYNC cable.
- 3 - Open the desired configuration in the SYSCON and put it in *On-line mode*. Right-click the *bridge* icon and with the option *Attributes* choose one of the modules listed in the field *Device Id*. The chosen module will be that one to be configured as *Main*.
- 4 - Even in the bridge icon, right-click the field *FB VFD* and then click *Block List*. A new window will be opened showing all the blocks pre-instantiated in the module. Then, in this window, right-click the *transducer* performing an *Assign Tag* with the *tag* that is predicted in the configuration. Close the *Block List* window.

- 5 - Right-click the *transducer* icon in the *bridge* and choose *On Line Characterization*. Set the parameter *FUNCTION_IDS* as *Sync_Main*. Through the synchronism path, the other module automatically will be initialized as *Backup*. After that, both the parameters *RED_SYNC_STATUS (L and R)* will indicate *Maintenance*, which means that neither of the modules was configured yet.
- 6 - If necessary, perform *Assign Tag* for all the *field devices*. Wait until the *Live Lists* of all the channels are complete. So, configure the system through the *Active* module executing all necessary downloads exactly the same way for a non-redundant MB-700 system.
- 7 – As soon as downloads are completed successfully, the transducer will show the following phases:
 - The *Active* will transfer the whole configuration to the other module (*RED_SYNC_STATUS_L* as *Updating Remote* and *RED_SYNC_STATUS_R* as *Maintenance*).
 - After the configuration is successfully transferred, the modules can take some time to synchronize (parameters *RED_SYNC_STATUS (L and R)* as *Synchronizing*). This is the time necessary to the modules to check the configuration with each other.
 - Finally, the modules will synchronize (parameters *RED_SYNC_STATUS (L and R)* as *Synchronized* and *RED_STATE_R* as *Standby*). Once the system is on these conditions, the *Active* will be constantly updating the *Standby*.

Changing Configuration

Just follow the steps 6 and 7 of the section “*First time configuration procedure*”.

Replacing a module with failure

- 1 - With the SYNC connector disconnected, insert the new module in the backplane.
- 2 - Update the firmware in the new module, if necessary. Perform a *Factory Init* in the new module in order to grant the default state.
- 3 - Connect the SYNC connector to the new module.
- 4 - The new module will be automatically recognized by the *Active* and both will stay in *Synchronizing* for some time. As soon the system get the *Synchronized* status and *<none>* in the parameters *Bad Conditions*, the redundancy will be fully available and failure simulations can be performed.

Correcting a failure in the Synchronism Channel

If there is a failure in the SYNC cable connection (if the cable is removed, for example), the synchronism will be lost, and the two modules will become active. When the failure is corrected (the SYNC cable is reconnected), the Main module will be the Active again. Then, both modules are in *Synchronizing* for a while. When the system has the *Synchronized* status and *<none>* in the *Bad Conditions* parameters, the redundancy will be available and failure simulations can be done.

Firmware update without process interruption

This procedure describes how to update the firmware of both the modules without process interruption.

- 1 – Be sure the system is in the *Synchronized* status and it has *<none>* in the parameters *Bad Conditions*. So, using FBTools update the firmware of the *Active* module. At this moment, the other module will take over.
- 2 - After the firmware update was finished, the modules will start to synchronize with each other, with the *Active* transferring all the configuration to the other one. Wait for the system get the *Synchronized* status and it has *<none>* in the parameters *Bad Conditions*.
- 3 - Using FBTools update the firmware of the *Active* module. At this moment, the other module will take over.
- 4 - After the firmware update was finished, the modules will start to synchronize with each other, with the *Active* transferring all the configuration to the other one. As soon the system get the *Synchronized* status and has *<none>* in the parameters *Bad Conditions*, the redundancy is fully available again and failure simulations can be performed.

Adding redundancy to an existing system

If a non redundant system is intended to be redundant in the future, in the plant startup the following conditions must be obeyed:

- Predict that the LAN architecture can be expanded in order to attend what is described in the “Supervision Redundancy via OPC”.
- The single module should use a redundant firmware that supports Hot Standby redundancy. The *Function_Ids* parameter should be set as *Sync_Main*. So the module can be configured and while there is only a single module, it will works in *Stand Alone* status.

SYNC_CABLE Physical Connection

The physical connection is simple as shows the picture below:

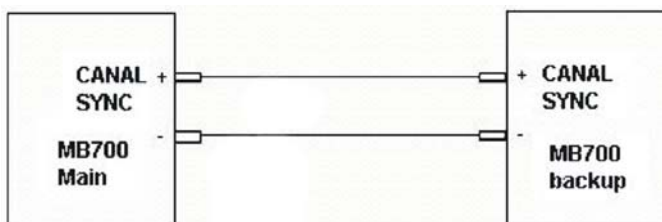

Additional Parameter Table

IDShell Transducer - New Parameters and Values for MB-700 Redundancy

Idx	Parameter	Data Type (length)	Valid Range/ Options	Default Value	Units	Store/Mode	Description
13	FUNCTION_IDS	Unsigned8	1:Passive 2:Active 3:Backup 4:Active_Not_Link_Master 7:Sync_Idle 8:Sync_Main 9:Sync_Backup	7	E	D / RW	Role for the local device in the redundancy Passive, Active, Backup and Active_Not_Link_Master are not synchronized roles, valid only for supervision and LAS redundancy. Hot Standby redundancy are set via the following roles: Sync_Idle is the default role, after factory initialization. The 4 th port is used to synchronize two different MB-700 processors. Sync_Main indicates the preferential processor to assume the tasks. Sync_Backup indicates the backup processor to assume the tasks.
169	RED_ROLE_L	Unsigned8	1:Passive 2:Active 3:Backup 4:Active_Not_Link_Master 7:Sync_Idle 8:Sync_Main 9:Sync_Backup	7	E	D / RO	Redundancy Role for the local device Idem FUNCTION_IDS description.
170	RED_STATE_L	Unsigned8	0:Not Ready 1:Standby 2:Active	0	E	D / RO	Redundancy State for the local device Not Ready – Not ready to run. Standby – Live but not running. Active – Running the tasks.

Idx	Parameter	Data Type (length)	Valid Range/ Options	Default Value	Units	Store/Mode	Description
171	RED_SYNC_STATU S_L	Unsigned8	0: Not defined 1: Stand Alone 2: Synchronizing 3: Updating Remote 4: Maintenance 5: Synchronized 6: WARNING: Role Conflict 7: WARNING: Sync Cable Fail 8: WARNING: Updating Remote Fail 9: Warning 1 10: Warning 2	0	E	D / RO	Synchronism Status for the local device 0: Initial value 1: Stand alone operation 2: Checking configuration for synchronize 3: Transferring all the configuration to remote 4: Receiving all the configuration from remote 5: The modules are completely updated with each other 6: The spare module has the same Role of that is running 7: Fail on the synchronism cable 8: Fail on the updating remote 9: Future use 10: Future use
172	RED_ROLE_R	Unsigned8	7:Sync_Idle 8:Sync_Main 9:Sync_Backup	7	E	D / RO	Redundancy Role for the remote device Idem FUNCTION_IDS description.
173	RED_STATE_R	Unsigned8	0:Not Ready 1:Standby 2:Active	0	E	D / RO	Redundancy State for the remote device Idem RED_STATE_L description.
174	RED_SYNC_STATU S_R	Unsigned8	0: Not defined 1: Stand Alone 2: Synchronizing 3: Updating Remote 4: Maintenance 5: Synchronized 6: WARNING: Role Conflict 7: WARNING: Sync Cable Fail 8: WARNING: Updating Remote Fail 9: Warning 1 10: Warning 2	0	E	D / RO	Synchronism Status for the remote device 0: Initial value 1: Stand alone operation 2: Checking configuration for synchronize 3: Transferring all the configuration to remote 4: Receiving all the configuration from remote 5: The modules are completely updated with each other 6: The spare module has the same Role of that is running 7: Fail on the synchronism cable 8: Fail on the updating remote 9: Future use 10: Future use
175	RED_BAD_CONDITI ONS_L	Bitstring(2)		0	E	D / RO	Bad conditions for the local device See detailed description on users manual
176	RED_BAD_CONDITI ONS_R	Bitstring(2)		0	E	D / RO	Bad conditions for the remote device See detailed description on users manual
177	RED_RESERVED1	Unsigned8	0 ~ 255	0	NA	D / RW	Reserved for future use.
178	RED_RESERVED2	Unsigned8	0 ~ 255	0	NA	D / RW	Reserved for future use.

Table 1

Description of meaning of RED_BAD_CONDITIONS_L / R bits

Bit	Variable
0	Modbus
1	H1-1 (not used)
2	H1-2 (not used)
3	H1-3 (not used)
4	LiveList
5	Res_1
6	Res_2
7	Res_3

TROUBLESHOOTING

The MB-700 allows a few initialization procedures to solve specific problems. These resources are :

ATTENTION

Any form of initialization will cause a serious impact in the system!

Reset

Click the right Push-Button (see details in the following figure which shows the two small buttons located above of the Modbus 232 connector) and the system will execute the RESET taking some seconds for correct system initialization. In accordance with the procedure via FBTools, at this moment, a new IP will be attributed automatically or the last configured IP will be accepted for the system. Verify that the Led RUN and Led ETH10 remain lit.

Factory Init

Keep the left Push-Button pressed and after that click the right Push-Button assuring that the Led FORCE is blinking once a second. Release the left Push-Button and the system will execute the RESET deleting the previous configurations.

Modo HOLD

Keep the left Push-Button and after that double click the right Push-Button assuring that the Led FORCE will be blinking twice a second. Release the left Push-Button and the system will execute the RESET and will go for HOLD mode. Verify that the Led HOLD and Led ETH10 remain lit. With the DFI302 in this mode, the user can use the FBTools Wizard for firmware update or alteration of IP address.

Use the Reset again, case you want to return to the execution mode (RUN).

TIP: Any mode (Factory Init and HOLD Mode) can be prevented once started, remaining the right Push-Button pressed, first releasing the left Push-Button.

TIP: If you loose the account of the times that the Push- right Bottom was pressed, it is enough to verify the number of times that the Led FORCE is blinking a second. It will come back to blink once a second after the fourth touch (the function is cyclic).

TIP: To "click" these Push-Buttons use some pointed instrument (for ex. Ballpoint pen).

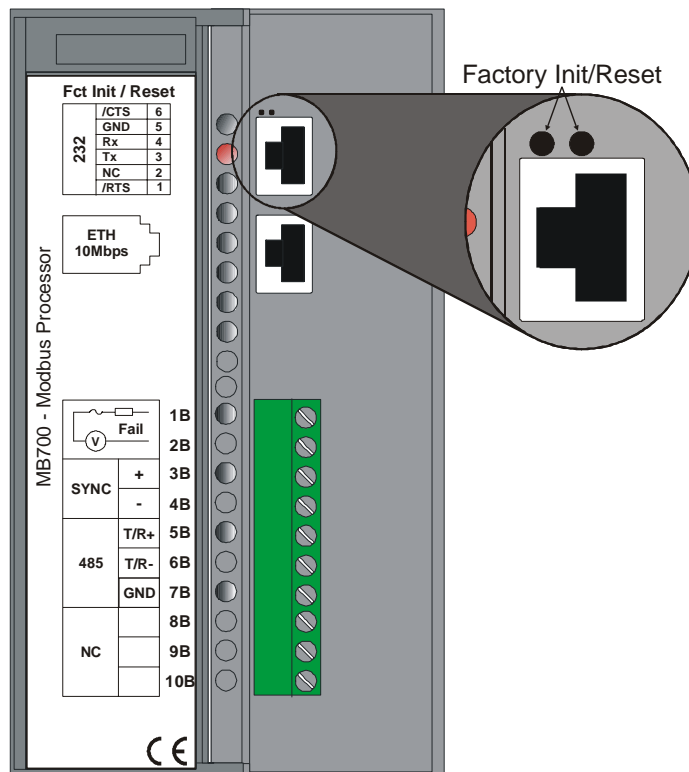

When to use the Factory Init/Reset procedure

1. How to reset the MB-700 without turning it OFF?

Use the RESET procedure.

2. The LED HOLD remains ON, what do I have to do?

In case after the MB-700 was turned ON (or after reset) the LED HOLD remains ON likely the firmware is corrupted. It must be done a new firmware download to upload a new firmware again.

Follow these steps:

- 2.1- Assure the MB-700 is turned ON and that it was connected to the Subnet. In case it was not, use the procedure “Connecting the MB-700 to the Subnet”. Be sure that the HOLD led is ON.
- 2.2- Run the FBTools Wizard.
- 2.3- In the main window (Choose device type), select the MB-700 and press the NEXT button.
- 2.4- Choose the path to the DFI OLE Server to be used (default: Local) and press the button NEXT.
- 2.5- Select the desired Module MB-700 using as reference the serial number.
- 2.6- Press the button “browse..” to select which firmware file will be uploaded (file MB-700*.ABS).
- 2.7- After selecting the file to be uploaded, press the button Finish to start the firmware download.
- 2.8- During download it will be presented an operation progress window.
- 2.9- At the end of this operation a status message of download will be presented. At this moment the MB-700 will be already in the RUN mode. Type OK (assure that the RUN led is ON).
- 2.10- To finish, hit Finish in the next window.

3. FBTools Wizard does not get to put the MB-700 in HOLD, how should I proceed?

Use the procedure for the HOLD mode. After the MB-700 is put in HOLD run the update procedure of the firmware using the steps of the item 2. If even then you still have troubles, likely it is related to the TCP/IP connection (check cables and the ETH10 LED).

4. Firmware starts an execution but soon after a while it locks, how should I proceed?

It may be a configuration trouble, use the Factory Init procedure and configure again the MB-700. In case the problem persists it will be required to upload again the firmware in the MB-700.

5. The ETH10 does not get ON, how should I proceed?

Check if the cable was assembled properly, or if the cable is not broken. Remember the cable specifications:

DF54 –Straight cable. To be used in a network between MB-700 and Switch/HUB.

DF55 – Cable Crossed (Cross) to be used point-to-point between PC and MB-700.

6. FORCE LED blinks, what do I do?

Use the RESET procedure.

7. The FBTools does not show all MB-700s in the subnet, what should I do?

Likely there is some IP address conflict in this subnet. To solve this kind of trouble disconnect all MB-700 in this subnet and run the procedure “Connecting the MB-700 in the Subnet” for each module assuring the address to be used is not associated to other device of this subnet.

8. The FBTools does not find the MB-700.

- Assure the initial procedure of connection was made, that is, it was initially put the default IP via reset mode 3 and the computer was set with IP 192.168.164.101.
- The Ethernet cable used must be DF54 when using a HUB or Switch. Use the DF55 cable if the connection is made directly from PC to MB-700.
- Test if the network board of your PC runs the PING command to the IP of the PC it self through the DOS PROMPT (WINDOWS NT). On Windows 2000 go to Start->Programs->Accessories and run the Command Prompt tool.
- Test if the Ethernet connection is OK running the PING command for the MB-700.

9. The MB-700 was working properly, I turned it off again and now any kind of reset does not work and the HOLD LED keeps constantly ON and/or blinking.

In this case it is necessary to use the Boot flash.

10. Do I need to use a Boot Flash to reload the program boot?

Use the factory procedure “Loading the boot program in the MB-700”.

11. During operation of the SYSCON in the ON LINE CHARACTERIZATION of some blocks I've lost connection with the MB-700.

Versions of the System 302 5.0 prior to Service Pack 8 have a bug where they could generate the effect above. In this case only closing the SYSCON and opening it again will solve this trouble. In some cases you will have to reset the MB-700.

12. The Get License program does not accept license.

Follow the next steps:

1. Try to register the DEMO license. In the GET LICENSE there is a button named USE DEMO KEYS. In case it works, the problem must be a mistake during typing of the key.

2. If still does not work check the existence of the SmarOlePath in the environment. Use Start->Programs->Administrative Tools\NT Diagnostics in the folder environment and check if there is a variable named SmarOLEPath. In case there is not run "interface Setup" of the Smar's working folder. This will create the variable. Use only characters that are numbers or lines "-". DO NOT use spaces and symbol characters "! @ # \$ % ^ & * () _ + ~ < > , . / ? \ | { } [] ; :".

3. Run the server register again. In the Smar's working folder (Program\Files\Smar\OLEServers) runs the program Register.bat.

4. In case all above options have failed it is possible to generate a license file manually: Use an ASC text editor (e.g. Notepad) because the file cannot have characters with format. The name of each file and its content are presented next.

File: Syscon.dat

SMAR-MaxBlocks-55873-03243-22123-04737-10406

File: OleServer.dat

#PCI OLE Server

SMAR-OPC_NBLOCKS8-23105-23216-11827-2196

File: DfiOleServer.dat

#DFI OLE Server

SMAR-DFIOPC_NBLOCKS8-19137-32990-37787-24881-12787

These files shown above are for the DEMO license, you may use your keys.

13. I try to change a static value of a MODBUS block but the value is not updated.

In order to update a static value of MODBUS block, it is necessary that first you put the target in question on OOS, which allows the static values to be changed,

14. After changing a static value of a block and put MODE BLOCK Target to "Auto" the actual mode does not go to "Auto".

If any static parameter of a MODBUS block was changed the block will go to Auto only after you have put the ON_APPLY parameter in Apply in the CCCF block.

Appendix B

CABLING

Ethernet cable Specification

In case it is necessary to assembly a new Ethernet cable, we present here the specifications to the Twisted Pair cable, according to Part Number DF54 or DF55.

DF54 – Straight Cable. Used in a network between MB-700 and Switch/Hub.

DF55 – Cross Cable. Used in a point to point communication between PC and MB-700.

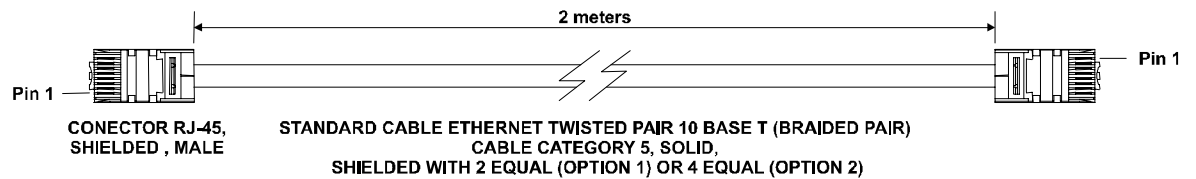

DF54		
1	Brown	1
2	White / Brown	2
3	Orange	3
6	White / Orange	6

DF55		
1	Brown	3
2	White / Brown	6
3	Orange	1
6	White / Orange	2

OBS: The colors are only suggestions, it is important to use the pars (colors XXX and white/color XXX);

Serial Cable Specification

To connect the serial EIA-232 port of the MB-700 to the SI-700 module (RS232/RS485 converter) it is necessary a DF59 cable or it must be assembled a cable according to the specifications next.

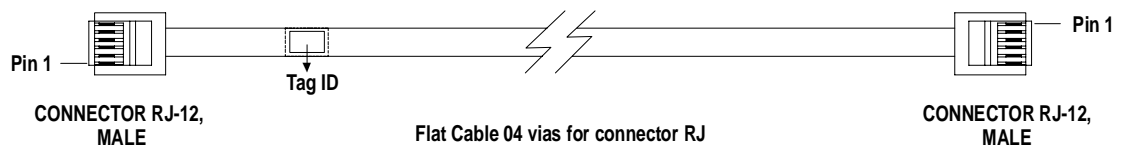

DF59		
3		3
4		4
5		5

To assembly a serial cable between the MB-700 (Processor) and your PC follow instructions described next showing the connection between a RJ12 (used in the MB-700) and a DB9 female.

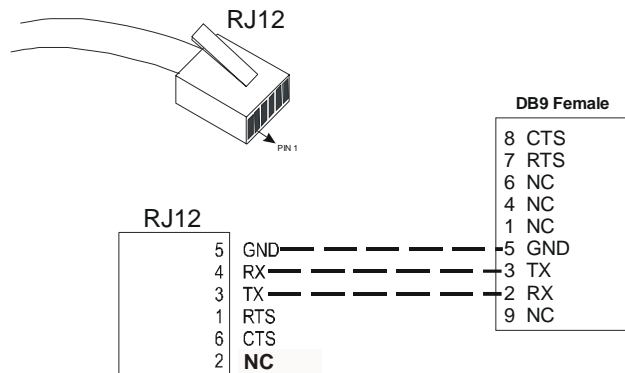

EIA-485 Interface

See the frontal panel of the MB-700 (Chapter 2).

Pins of terminal block

Pin	Description
5	+: EIA-485
6	-: EIA-485
7	GND. Reference for communication signal EIA RS-485

Cable Specifications to connect the MB-700 to the LC700

This cable follows specifications showed next:

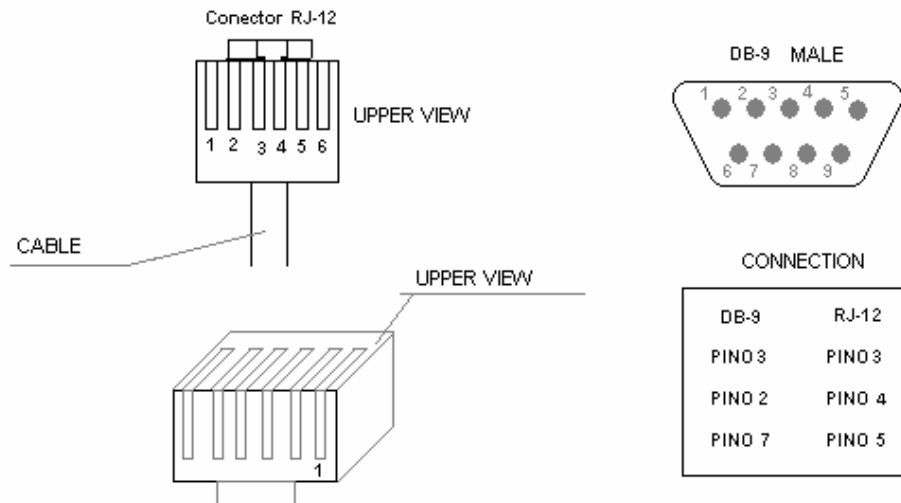

TECHNICAL SPECIFICATIONS

Technical Specifications for the MB-700 module

CONTROLLER	
Type	32 Bit RISC (CPU Clock @25 MHz)
Performance	50 MIPS
Code Memory	2 Mbytes, 32 Bits Flash Memory (Firmware recordable)
Data Memory	2 Mbytes, 32 Bits NVRAM (Data storage and configuration)

COMMUNICATION PORTS	
Ethernet	1 Ethernet port @10 Mbits (Connector RJ-45)
Serial	1 EIA-232 port @ 9.6 Kbps-115,2 Kbps (Connector RJ11) 1 EIA-485 port @ 9.6 Kbps-115,2 Kbps
Synchronism channel	1 Independent port with DMA-Baudrate 31,25 Kbps (SYNC)

INTERNAL POWER	
Supplied by the IMB	5Vdc/ 950 mA
Total dissipation	4.75 W

STATUS INDICATION	
+5VDC	Green LED indicating Module Powering
Fail	Red LED indicating processor failure
Run	Green LED indicating program running
Hold	Yellow LED indicating program in FORCE
Force	Not used
232/485 TX	Green LED indicating data transmission (serial EIA-232 and EIA-485)
ETH 10	Green LED indicating Ethernet cable connected
ETH TX	Green LED indicating data transmission through Ethernet
SYNC	Green LED indicating data synchronism
Standby	Green LED indicating the module is in standby (waiting state when it is redundant)

DIMENSIONS AND WEIGHT	
Dimensions (W x H X D)	39.9 x 137.0 x 141.5 (mm) 1.57 x 5.39 x. 5.57 (in.)
Weight	0.340 kg

TEMPERATURE	
Operation	0 °C to 60 °C
Storage	-30 °C to 70 °C

CABLES	
One Wire	14 AWG (2 mm ²)
Two Wires	20 AWG (0.5 mm ²)

Data Types available for the parameter DATATYPE

Number of Data type	Data Type	Description
1	Integer8	Integer signed (1 Byte)
2	Integer16	Integer signed (2 Bytes)
3	Integer32	Integer signed (4 Bytes) - (big-endian)
4	Unsigned8	Integer signed (1 Byte)
5	Unsigned16	Integer signed (2 Bytes)
6	Unsigned32	Integer signed (4 Bytes)) - (big-endian)
7	FloatingPoint	Float point - (big-endian)
8	Swapped Integer8	Integer signed (1 Byte)
9	Swapped Integer16	Integer signed (2 Bytes)
10	Swapped Integer32	Integer signed (4 Bytes) –(little-endian)
11	Swapped Unsigned8	Integer signed (1 Byte)
12	Swapped Unsigned16	Integer signed (2 Bytes)
13	Swapped Unsigned32	Integer signed (4 Bytes) –(little-endian)
14	Swapped FloatingPoint	Float point –(little-endian)

Observation: For data types with 4 bytes, the swapped data type has a data inversion (little-endian); related to the not swapped data type (big-endian). For each data type with 1 and 2 bytes, there is no difference between swapped and no-swapped.

For example, it considers a number with 4 bytes 12345678 located in the Modbus addresses 40001 and 40002:

- Data allocation for Unsigned32 data ype (Big-endian)

Endereço Modbus	Dado
40001	5678
40002	1234

- Data allocation for Swapped Unsigned32 data type (little-endian)

Endereço Modbus	Dado
40001	1234
40002	5678

Scale Conversion

The blocks that support Scale conversion are listed below:

- **CCSM**
 - EU_ADDRESS_A/EU_ADDRESS_B
- **CCCM**
 - EU_ADDRESS_IN1 a EU_ADDRESS_IN2
 - EU_ADDRESS_OUT1 a EU_ADDRESS_OUT2
- **CCDL**
 - EU_ADDRESS_A1

The scale conversion for Modbus protocol has two purposes:

- Conversion from an internal analog value of block to a Modbus value in Engineering Units;
- Conversion from a Modbus analog value to an internal value of block in Engineering Units.

The scale parameters are composed by the following items:

- FROM_EU_100% - it defines the high value of the input unit (actual data unit);
- FROM_EU_0% - it defines the low value of the input unit (actual data unit);
- TO_EU_100% - it defines the high value of the output unit (data unit desired by user);
- TO_EU_0% - it defines the low value of the output unit (data unit desired by user).

Observation

There are many different structure data that have scale conversion; therefore they follow the same conversion procedure.

$$A = (TO_EU_100\% - TO_EU_0\%) / (FROM_EU_100\% - FROM_EU_0\%)$$

$$B = TO_EU_0\% - A * FROM_EU_0\%$$

$$Y = Ax + B$$

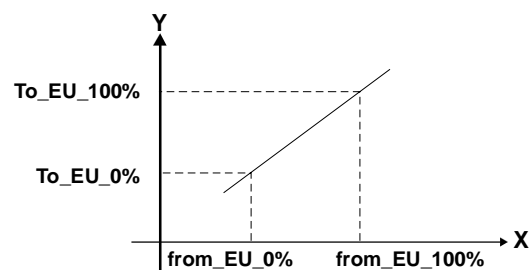

Where x is the variable read from the input slave device and Y is the output variable.

