

# An Information Model for Process Control on Machine Tools\*

Sanjeev Kumar<sup>1</sup>, Stephen T. Newman<sup>2</sup>, Aydin Nassehi<sup>2</sup>,  
Parag Vichare<sup>2</sup>, and Manoj K. Tiwari<sup>3</sup>

<sup>1</sup> Machine Tool Products Division, Renishaw  
Sanjeev.Kumar@renishaw.com

<sup>2</sup> Department of Mechanical Engineering, IdMRC, University of Bath  
S.T.Newman@bath.ac.uk, A.Nassehi@bath.ac.uk,  
P.Vichare@bath.ac.uk

<sup>3</sup> Industrial Engineering & Management, IIT Kharagpur  
mkt09@hotmail.com

**Abstract.** Recent advances in technologies involved in CNC manufacturing systems have provided industry with the capability to machine complex products. However, there is still no guarantee for these advanced systems to manufacture products to their required specification the first time. This results in large scrap rates of manufactured components and requires skilful resources (human/bespoke solutions) to adjust the involved processes. The solution to this problem is the development of a machine tool process control system which would be able to provide the corrective measures in-process. At the core of this system, is a kernel to map the information in the manufacturing CAx chain. Using the existing high level information on component design, machining processes, manufacturing resources and measurement, process control can be maintained. This leads to seamless information flow in the manufacturing process chain. This paper presents and describes a machine tool process information model. A computational platform for developing a machine tool process control system has then been discussed. This computational prototype has been further realised and demonstrated using a prismatic case study component.

**Keywords:** Process Control, Information Modelling, STEP-NC.

## 1 Introduction

Automation has significantly transformed industries in becoming more responsive to customers demand. This has helped the supply chain in the majority of industries to deliver goods globally at a satisfactory level. However, the supply chain in high value manufacturing suffers due to the inability of vendors in providing quality products at the right time. These industries are comprised of precision manufacturing, aerospace and even mass manufacturing such as in the automotive sector. One of the major

---

\* This work was done in the University of Bath.

issues in these industries is to control the rejection rates of the manufactured products. This would eventually help in reducing the lead time for these products on the manufacturing shop-floor.

The complex nature of different manufacturing processes, and particularly their analysis and control has always presented a major challenge for researchers as well as practitioners. The processes in these systems are required to be controlled so that they can adjust to variations in the production and measurement processes automatically and consistently manufacture quality assured parts.

The manufacturing chain in these industries is complex and consists of various stages. These stages include designing, planning the manufacturing processes, manufacturing (e.g. machining/casting/forging) and measurement of the products. The measurement results are analysed in accordance to design requirements and respectively decisions for accepting, rejecting and reworking these products and the involved processes are made. However in today's manufacturing, the information context is not preserved during the production and thus analysing the results and taking decisions is difficult, time-consuming, expensive and inaccurate. To improve decision making, it has become vital to model this manufacturing process information. The research reported in this paper defines the modelling information required to control the machining process. This process information model is used in developing a real time manufacturing feedback system. This system will automate the decision making process and control the manufacturing processes. This system will result in a reduction in the scrap rate on the shop floor as well as lead time. A computational vehicle to enable machine tool process control is then presented.

## 2 Literature Review

Standards for product design, process planning, machining, CNC controller and metrology systems have been developed over a number of decades. These standards provide the information related to part design through to part measurement. The review in this paper is focussed on measurement standards as measurement is an integral of manufacturing process and has not been properly modelled to be integrated in the manufacturing CAX chain.

The existing metrology standards aim to provide the definition and execution of the inspection tasks along with the analysis of the results. Many standards have been developed for the exchange of inspection process information and measurement results are DMIS (DMIS 3.0, 1995), STEP standard for dimensional inspection process planning AP 219 (ISO 14649-219, 2005), DML, STEP-NC part 16 and I++ DME interface .

i) Dimensional Measuring Interface Standard (DMIS): The DMIS standard is used to communicate the dimensional measurement program sequences and results for manufacturing inspection. This provides the bi-directional communication of inspection data between computer systems and inspection equipment and is independent of the vendor (DMIS 4.0, 2001). This standard is widely used with CMMs and is presented as an intermediate file format between a CAD system and a CMM's native proprietary inspection language. A mechanism is provided by DMIS in the form of a neutral file to integrate dimensional planning and the execution system. Inspection features and tolerances, part co-ordinate systems and datum reference

systems, measurement sequencing, definitions of rotary table and sensors, and data input are specified using DMIS for dimensional measurement of parts on a CMM.

There are two distinct but related parts of DMIS in the form of ANSI and ISO standards which have been documented separately and used for inspection on CMMs. The development for the DMIS standards was initiated in 1985 as a Dimensional Measuring Interface Specification Project and resulted in the first two versions of the standards namely DMIS 1.0 and DMIS 2.0 in 1986 and 1987 respectively. ANSI accepted the next two versions DMIS 2.1 and DMIS 3.0 in 1990 and 1995. Finally DMIS 4.0 was accepted as an ANSI standards in 2001.

ii) Dimensional Markup Language (DML): The Dimensional Markup Language (DML) (DML 2.0, 2004) is used for transforming the dimensional measurements obtained from inspection devices into a standardised file. This file is then provided for analysis and reporting software to carry out the necessary analysis (Schafer, 2004). DML transforms the dimensional results into a standardised data format based on XML technology.

iii) STEP AP 219: STEP AP 219 is a working draft of a part of the STEP standard that describes the application protocol for dimensional inspection information exchange. Kramer (2001) envisages this standard of inspection planning to be fully integrated into the STEP data flow. It is believed that STEP AP 219 will provide the standard for the inspection results as raw data which will be suitable for evaluation in external systems as well as useful for feedback to CAD systems. STEP AP 219 is supposed to provide the interoperability with others available Application Protocols (APs) for in-process gauging which is currently not possible with the DMIS standard. A neutral file format is specified by STEP AP 219 that defines the inspection features and the tolerances.

iv) STEP-NC part 16: This standard is developed to allow capabilities for performing inspection operations in a STEP-NC manufacturing environment. The STEP-NC part 16 standard (ISO 14649-16 WD, 2004) is available only as a working draft for the present covering touch probe based inspection and allows a user to define the necessary inspection process information as well as Geometrical Dimensioning and Tolerance (GD&T) data. One of the benefits of using this standard is direct utilisation of STEP data in avoiding data conversions when applied in a manufacturing CAX chain. Using this standard, inspection entities and results of these results can be provided. Thus enables the data structure for the exchange of GD&T data along with process information.

v) I++ DME-Interface: The specification for CMM equipment level interface known as the "I++DME" interface has been developed with the support from automobile industries such as BMW, Daimler Chrysler, Volvo (Horst, 2004). This has been developed for providing communications protocol, syntax and semantics for command and response across the interface. I++ DME specifically provides the low-level inspection instruction commands for driving CMMs and is independent of the data formats for inspection planning and storage of dimensional measurement results.

Some of the limitations of DMIS as compared to STEP AP 219 and STEP-NC part 16 are outlined as follows:

i) DMIS provides the information related to simple geometric element and does not describe the part completely in terms of its inspection entities and activities as compared to STEP-NC part 16 standards.

ii) Vorburger (2000) recognised that DMIS is not capable enough to allow integration between inspection results and analysis and the original design information.

iii) Inspection results are stored in a different format using DML and it again requires further data conversion if it is needed to be integrated in CAx chain which may result in data inconsistencies that can lead to a loss in the manufacturing context of parts.

This review has identified the standards for the product design through to machining and measurement processes. In recent years, STEP-NC i.e. ISO 14649 & AP 238 data models have been developed to offer the opportunity to effectively maintain high level and standardised information. This is achieved by a new breed of intelligent STEP compliant CNC controller that facilitates bi-directional information exchange between CNC and CAD/CAPP/CAM software. The STEP-NC standards, i.e. ISO14649 part 10, 11 and 16 provide high level information in the form of technological data. However, the current STEP-NC standards have not been developed completely and information models related to machine resources and their capabilities do not exist.

### 3 Machine Tool Process Control

The authors have defined process control (Kumar et. al., 2007) in CNC manufacturing as the *“ability to monitor machining parameters and apply corrective measures where appropriate, in order to provide confidence in the machine tools to consistently produce parts within the best tolerances it can manage”* Measuring manufactured parts and storing the results in an appropriate format is an important requirement of process control in machining. The authors vision for achieving process control is to utilise standards for integrating high level information and knowledge across the process chain of product design, process planning, machining, measurement and data feedback. This enables the specification of the machining know-how at the abstract level i.e. what and how to manufacture and inspect, and also what and how to feedback by monitoring the integrity of the data throughout the process control chain.

Recent research efforts related to standards have revolutionized the conventional method of CNC programming by introducing new standards such as STEP-NC which are claimed to radically improve the information interface with the CNC machine tool. These new standards aim to provide a new breed of information for manufacturing of discrete components on the CNC machine that store geometry features of parts in conjunction with the manufacturing methods which are required to manufacture the part. STEP-NC has been recognised as an enabler for achieving process control due to its ability to provide seamless integration between product and manufacturing process information models, thus maintaining the integrity of data across the process chain.

With the development of STEP-NC standards for measurement combined with the application of touch trigger probes, there is an enormous potential to realize process control in a standardised manufacturing environment. STEP-NC standards provide the flexibility to store the inspection results in the same file containing the geometrical, manufacturing process, tooling and measurement information. Compensation methods

have been used for analysing these inspection results that enable the modifications of a feature's geometrical parameters, machining process and tooling parameters to be carried out at the preceding levels of the manufacturing CAx chain. These methods use optimisation techniques for analysing the measured results and provide feedback parameters to satisfy the desired criteria such as minimising the dimensional errors for a component and its features.

The current manufacturing CAx chain makes use of a range of proprietary standards and irreversible data conversion systems. Thus if the adjustments for the variations in the processes are carried out in the later stages of the CAx chain, it results in a loss of precision and accuracy in the manufacturing and measurement context of a component. The uni-directional information flow makes it nearly impossible to feedback the corrective measures after the analysis of inspection results to the planning and design stages of the CAx chain. One of the possible solutions to overcome these problems of current process control loop of CNC manufacturing is to use STEP-NC standards that provide interoperability across the manufacturing CAx chain.

#### 4 Information Constructs for Process Control System

The STEP-NC compliant product and manufacturing information model offers standard structured information related to the component and its features, material, tolerances, machining specifications and inspections specifications. In addition, it is further used to generate a machining and inspection process plan for a component. The product and manufacturing information model is depicted in Figure 1.

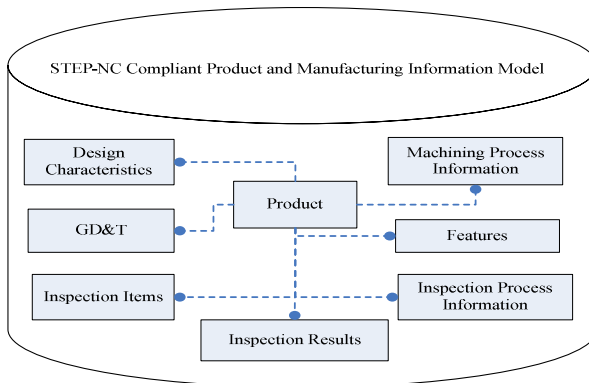

**Fig. 1.** Product and Manufacturing Information Model

- Part design, GD&T specifications and its features,
- Machining specifications,
- Inspection specifications, and
- Inspection results.

#### 4.1 Information Model for Component's Design, GD&T Specifications and Its Features

The product model based on ISO 14649-10 defines the component as workpiece and associates this with its shape tolerance, its geometry and its bounding geometry. The shape tolerance is the global tolerance for the component and it is defined in absence of any other tolerances. The component geometry is defined based on ISO 10303-514 (ISO 10313-514, 2005). Bounding geometry helps in defining the component either as box, a cylinder or a geometry based on *advanced\_brep\_shape\_representation* attribute ref-erenced from ISO 10303-514. This workpiece entity of ISO 14649-10 is defined as follows:

```
Entity workpiece
Its_geometry:          OPTIONAL advanced_brep_shape_representation;
Its_bounding_geometry: OPTIONAL bounding_geometry_select;
global_tolerance:     OPTIONAL shape_tolerance;
END_ENTITY
```

#### 4.2 Information Model for Machining Specifications

This product information model defines machining features based on ISO 14649-10 and is subtype of 2½ D manufacturing features. The tool movements for 2½ D machining occur mostly in xy plane and a Z axis is set to a certain depth for taking away a layer of material. This depth is provided by *elementary\_surface* attribute that denotes actual location of the feature in the co-ordinate system of component. This is defined by a plane that includes the lowest points of the feature as measured in its local co-ordinate system. This entity is defined in ISO 14649-10 as follows:

```
ENTITY machining_feature
ABSTRACT SUPERTYPE of (ONEOF (planar_face, pocket, slot, step, round_hole, boss));
SUBTYPE of (two5D_manufacturing_feature);
depth: elementary_surface;
END_ENTITY;
```

The product information model uses ISO 14649-16 standards to represent the inspection items of components. Inspection items are defined by attaching tolerances to the geometrical elements which could be either of the attributes of the manufacturing feature such as length of a rectangular pocket, relations within one feature such as distance between two sides of a pocket, or relations between two different items such as parallelism for a hole towards a plane. These inspection items represent toleranced dimension item, toleranced spanning dimension item, toleranced pose item and toleranced shape item. Toleranced dimension item specifies an inspection item with a toleranced dimension which is generally one geometrical attribute. Toleranced spanning dimension item is defined for more than one feature. Toleranced pose item represents the transition as well as rotation whereas toleranced shape item describes a tolerance for a shape. This inspection item is defined as follows according to ISO 14649-16:

*ENTITY inspection\_item*  
*ABSTRACT SUPERTYPE of (ONEOF(toleranced\_dimension\_item, toleranced\_spanning\_item, toleranced\_pose\_item, toleranced\_shape\_item))*  
*Its\_id: STRING;*  
*toleranced\_result: OPTIONAL inspection\_result;*

STEP-NC compliant product information model provides the provision for storing the measurement results for inspection items of a component. This model uses ISO 14649-16 that defines inspection result entity as a container to store the result of the inspection activity. The circumstances at the time of the probing activity that cause the measurement results are also stored. This entity is presented as follows:

*ENTITY inspection\_result*  
*ABSTRACT SUPERTYPE;*  
*its\_measured\_result: inspection\_result\_select;*  
*its\_model: inspection\_model\_select;*  
*circumstances: LIST[1:?] OF inspection\_circumstances\_select;*  
*END\_ENTITY*

A link has been established among the measured results, inspection items, manufacturing features, workingsteps and executables entities of ISO 14649 suite of standards by this product information model and presented in Figure 2.

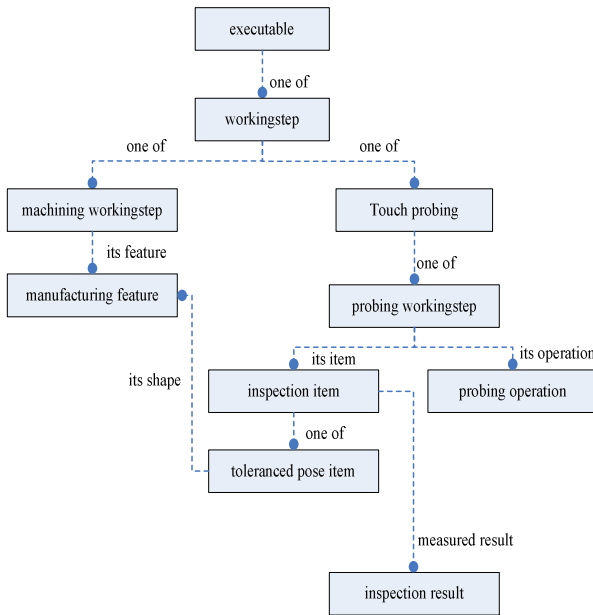

**Fig. 2.** Association of measured results with various entities in the STEP-NC compliant product model

## 5 Process Control Information Model for Resources

The data models developed represent the manufacturing process information in the form of the process control information of the resources such as CNC machine tool or CMM. STEP-NC compliant manufacturing process information model includes the information related to resource, resource unit and accuracy information for the resources as depicted in figure 3.

The primary objective in developing this model is to map the available machine tool and inspection resources for carrying out process controlled performance. The STEP-NC standards to represent the resources and its process control information are still do not exist (Vichare et al. 2008). The authors have provided the data models for representing the process control information of the machine tool in this research. This representation can be considered as the basis for future development of ISO standards for process control of resources.

Machine tool entity is used to define the attributes of resources such as CNC machine tool, CMM etc. The attributes of machine tool in terms of its name and manufacturers name are presented. Axis2\_placement\_3D (ISO 10303-224, 2000) is used to define the placement coordinates of the machine tool. A set of machine units are considered to be attached to this resource. These machine units are defined by attribute its\_machine\_tool\_unit which determine the different functionality of the machine tool. The representation of this entity is provides as follows:

```

ENTITY machine_tool
SUPERTYPE;
its_name: label;
its_manufacturer: label;
its_placement: axis2_placement_3D;
its_machine_tool_unit: SET[0:?] of machine_units;
END_ENTITY

```

Machine unit entity comprises of attributes such as identifier, name, the axes attached to it, the workpieces and machine tools mounted on it and its reference point. This entity is represented as follows:

```

ENTITY machine_unit
SUPERTYPE;
its_id: identifier;
its_name: label;
its_reference_point_placement: axis2_placement_3D;
its_workpiece: SET[0:?] of workpiece;
its_axis: SET[0:?] of axis;
its_machining_tool: SET[0:?] of machining_tool;
END_ENTITY

```



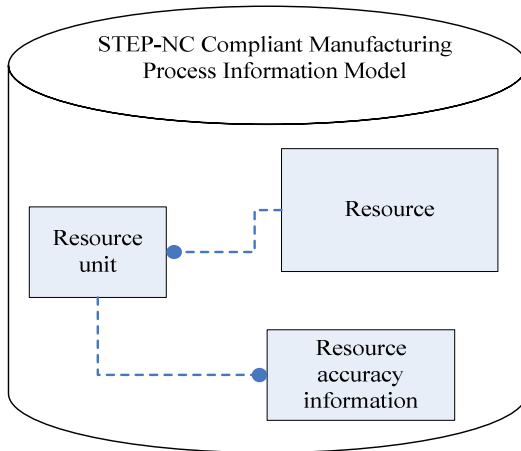

**Fig. 3.** Manufacturing process information model

The machine tool unit's kinematics aspects are defined using entity axes. Individual axes are attached to the machine tool unit to represent the respective degrees of freedom. These axes are categorised as linear axes and rotary axes. The process control information for a machine tool is attached with the axes in terms of its accuracy information. The entity axis and its various attributes are as listed as follows:

```

ENTITY axis
  SUPERTYPE of (one of(linear_axis, rotary_axis));
  its_id: identifier;
  its_name: label;
  its_direction: direction;
  its_accuracy_information: accuracy_information;
END_ENTITY
  
```

The liner axis and rotary axis are defined with their properties related to the feed, speed, travel range and movements. One such attribute is measurement travel that signifies the part of the axis travel utilised to select the initial and target positions. This attribute is defined using `axis2_placement_3D` and later utilised to provide the accuracy information for the axes. Entity linear axis is presented as follows:

```

ENTITY linear_axis
  SUBTYPE of axis;
  its_rapid_movement: BOOLEAN;
  its_feed_movement: BOOLEAN;
  its_max_rapid_speed: speed_measure;
  its_max_feed_speed: speed_measure;
  its_max_travel_range: axis2_placement_3D;
  its_min_travel_range: axis2_placement_3D;
  its_measurement_travel: axis2_placement_3D;
END_ENTITY
  
```

Accuracy information is a property associated with the axis of the machine tool unit. The authors has proposed the data model for the accuracy information of the axis of machine tools and represents the process control information of the machine tools. The accuracy information is presented as uni-directional accuracy, bi-direction accuracy, uni-directional positional deviation, bi-directional positional deviation, uni-directional repeatability and bi-directional repeatability of an axis. Accuracy relates to achieving a particular location and repeatability signifies the machine tool’s ability to adjust a particular location consistently. The other parameters of this entity are extended uncertainty and axial factor. The extended uncertainty characterizes a range for the result of a measurement that may include a large fraction of the distribution of values. This axial factor is utilised as a multiplier of the combined standard uncertainty to attain the extended uncertainty.

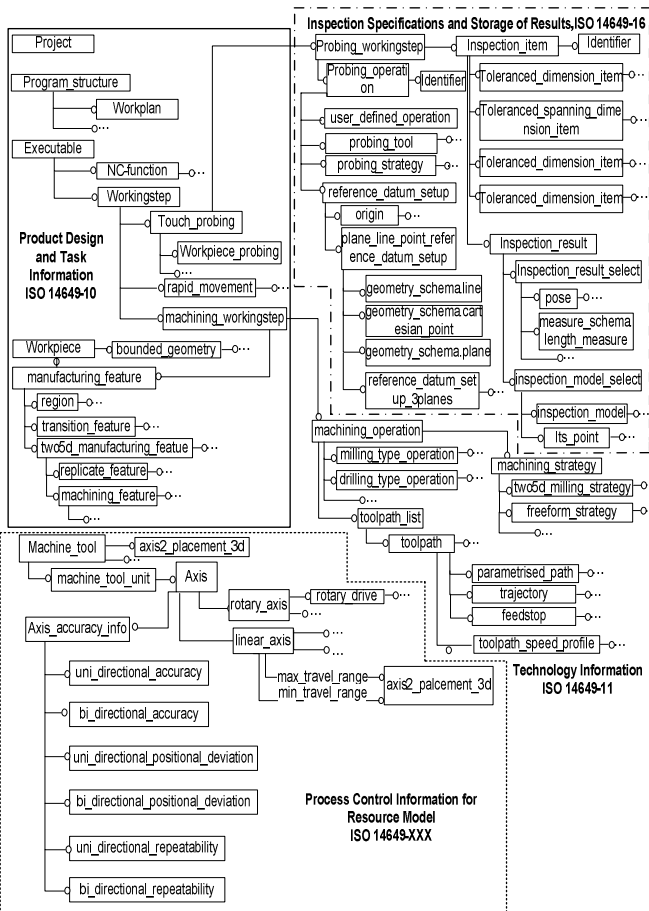

Fig. 4. Machine Tool Process Control Information Model

```

ENTITY accuracy_information
  SUPERTYPE of (uni_directional_accuracy, bi_directional_accuracy,
  uni_directional_positional_deviation, bi_directional_positional_deviation,
  uni_directional_repeatability, bi_directional_repeatability)
  its_direction: direction;
  its_axial_factor: REAL;
  its_extended_uncertainty: REAL;
END_ENTITY
    
```

An EXPRESS-G representation for the data models of STEP-NC compliant product information model and manufacturing process information model is presented in figure 4.

### 6 Object Oriented Platform for Process Control System

The product information model has been used to generate the STEP-NC compliant machining and inspection process plan. STEP-NC data models are utilised for developing the process plan that includes the workpiece, workplan, machining and probing workingsteps, manufacturing features, inspection items and results. Integrated platform for process planning and control (IP<sup>3</sup>AC) (Nassehi, 2007) has been used as an object oriented interface for facilitating the data exchange with STEP-NC data models. The data structures utilised to generate the machining and inspection process plan are presented in figure 5.

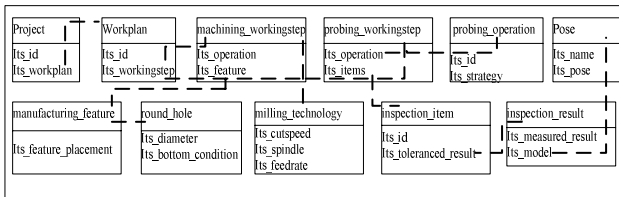

Fig. 5. Machining and inspection information objects

These data structures are then encapsulated in objects with IP<sup>3</sup>AC. This is used in JAVA program that employ machining and inspection information in data structures and a STEP-NC compliant machining and inspection plan is developed. An abstract of this process plan generated using IP<sup>3</sup>AC is depicted in figure 6. This process plan is generated in a text file format conforming to ISO 10303-21 standards. A machine tool process control system will be able to use this STEP-NC compliant machining and inspection process plan and updates this with the measurement results. The data structures for the storage of measurement results, its locations, models and circumstances are defined by the STEP-NC compliant product model.

The manufacturing process information is used in similar way to generate the process control information of a machine tool resource. The data models of the process control

```

ISO 14649 file (10303-21)

#1=PROJECT('Sanjeev Test Piece',#2,(#10),$,,$,);
#2=WORKPLAN('Main Workplan',#3,#30,#49,#68,#87,#94,#100,#106),$,,$,);
#3=MACHINING_WORKINGSTEP('Drilling',#4,#9,#18,$,);
#4=PLANE('Drilling plane',#5);
#5=AXIS2_PLACEMENT_3D('Axis for Drilling plane placement',#6,#7,#8);
#6=CARTESIAN_POINT('point for Drilling plane placement',(0,0,0,10,0));
#9=ROUND_HOLE('Hole1',#10,(#18),#19,#23,#28,$,#29);
#10=WORKPIECE('Simple Workpiece',#11,0,01,$,#13,());
#13=BLOCK('block for Simple Workpiece',#14,150,0,150,0,50,0);
#14=AXIS2_PLACEMENT_3D('Axis for axis for block for Simple Workpiece',#15,#16,#17);
#86=THROUGH_BOTTOM_CONDITION();
#87=PROBING_WORKINGSTEP('Hole1',#88,$,#89,(#91));
#88=PLANE('Security plane',#90);
#89=PROBING_OPERATION('probing round hole axial position',#90,$,#90);
#90=PROBING_STRATEGY('null');
#91=TOLERANCED_POSE_ITEM('axial position',#92,#9,#93);
#92=INSPECTION_RESULT(#116,$,(#9));
#93=POSITION_TOLERANCE(0.1,());
#94=PROBING_WORKINGSTEP('Hole2',#88,$,#95,(#97));
#95=PROBING_OPERATION('probing round hole axial position',#96,$,#96);
#96=PROBING_STRATEGY('null');
#97=TOLERANCED_POSE_ITEM('axial position',#98,#36,#99);
#98=INSPECTION_RESULT(#121,$,(#9));
#99=POSITION_TOLERANCE(0.2,());
#112=AXIS2_PLACEMENT_3D('Axis for Placement for Hole',#113,#114,#115);
#113=CARTESIAN_POINT('point for Placement for Hole',(15.23,15.06));
#114=DIRECTION('axis direction for Placement for Hole',(0,0,0,1,0));
#115=DIRECTION('reference direction for Placement for Hole',(1,0,0,0,0));
#116=POSE('measured positior',#112);
ENDSEC;
    
```

Fig. 6. An abstract of generated STEP-NC compliant machining and inspection process plan

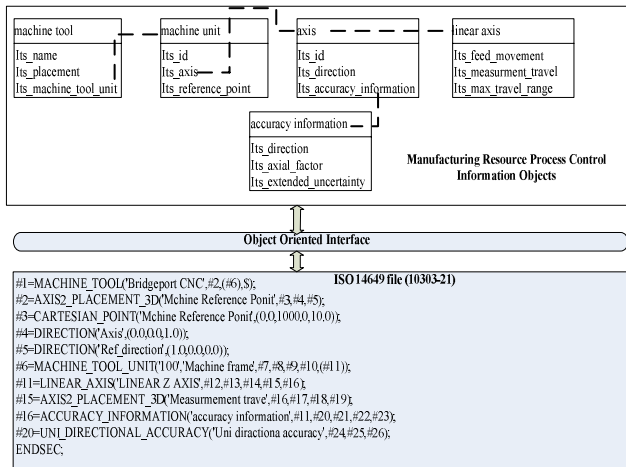

Fig. 7. Process control information of machine tool resource

for machine tool resources is utilised with an object oriented interface and process control file for a machine tool resource is generated. The data structures employed to represent the process control information of resources are depicted in figure 7.

## 7 A Computational Vehicle for Machine Tool Process Control

To implement process control in an existing manufacturing system, a computational vehicle has been developed by using machining and information objects in a Java based object oriented platform. This system relies on a CAX information hub for CNC manufacturing which can use the information from different stages of a product's life cycle. This information is processed in a unified and standardised manner to provide an updated and modified process plan which can be used in present manufacturing systems to carry out the production of parts in a process controlled manner.

This system uses evolving interoperable STEP-NC standards and a neutral file format for process planning to share and update information across the CAX process chain. This neutral file format is represented as an encoded text file according to the ISO 10303 part 21 standards. The text encoded file has been shown to contain the design, process and measurement information at different stages in the CAX chain. The data transfer mechanism in the manufacturing CAX chain is shown in Figure 8.

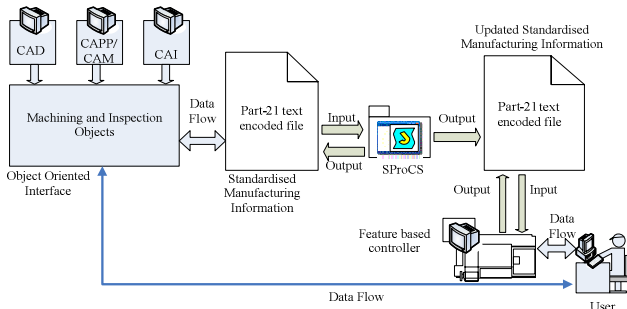

**Fig. 8.** Data transfer mechanism in CAX manufacturing process chain

The part design, its various processes and inspection information can be obtained from the feature based CAD, CAPP/CAM and CAI systems. This information can be acquired and integrated using an object oriented interface for machining and inspection objects (explained in section 6) and is presented in a text encoded file using an ASCII form of data transfer. A text encoded part 21 file contains standardised manufacturing information provided as an input to the process control system.

This system updates the nominal standardised manufacturing information with the compensated parameters based on manufacturing data analysis. The updated process plan file is then provided to a feature based controller such as Siemens 840D with Shopmill for performing the product of parts using a CNC machining centre. The Siemens 840D is able to read the STEP-NC based machining and measurement process plan, due to the similarity with STEP-NC in feature and process definitions within this controller. The standardised manufacturing information which essentially is a process plan is independent of any specific CAD/CAPP/CAM/CAI system. This manufacturing information file is also updated with the measurement results and modified with the compensated parameters in a resource independent manner.

## 8 A Case Study Example

A simulated environment of the developed process control system is illustrated using a prismatic test part. The CAD design of this prismatic part in 2D is shown in Figure 9. This part design comprises of four hole features and their nominal placement coordinates in X and Y are (15, 15), (15, 135), (135, 15), (135, 15).

The required machining processes for this test piece are face milling and drilling operations. The inspection items in this case study are the positional tolerances for the four hole features. The developed process control system has been realised for this test part and an updated process plan is obtained which able to manufacture parts with minimised positional deviations of features placement locations.

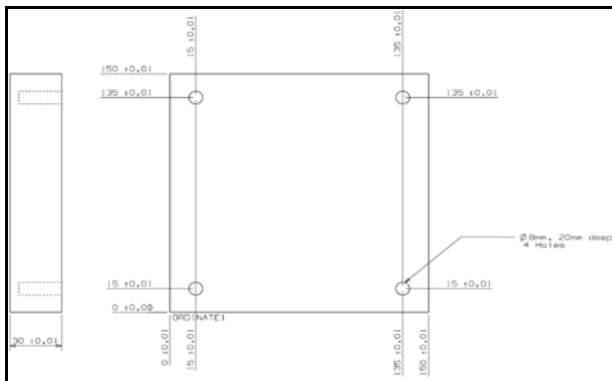
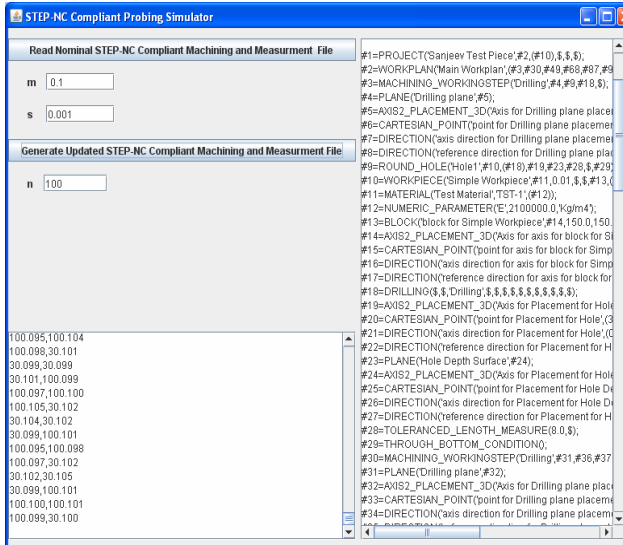

**Fig. 9.** Design of a test part

The detailed descriptions of the machining operations, processing parameters, tooling, fixturing, probing operations are not presented in this paper. This paper only focuses on showing the functionality of a process control system.

A STEP-NC compliant process plan in part 21 file format for the test part is created. This includes a workplan, machining workingsteps, probing workingsteps, nominal design requirements of tolerances and placement locations for the manufacturing features, tooling, machining process parameters, security planes, probing strategies, probing tools and inspection items. To read this nominal process plan, a STEP-NC compliant probing simulator has been developed. The probing simulator reads and stores the nominal feature placement coordinates and simulates the probing results for these features based on the mean and standard deviation for the production profile.

In this screenshot, a user interface of the simulator has been shown. In the user interface of the simulator, two options namely reading the nominal STEP-NC compliant machining and measurement file and generate updated STEP-NC compliant machining and measurement file. The values of mean and standard deviation are provided as inputs which are shown by  $m$  and  $s$ . The number of measurements to be



**Fig. 10.** Reading of machining and measurement file and simulating probing results using STEP-NC compliant probing simulator

simulated is shown by n. In the right hand box of the simulator user interface, an excerpt of a nominal STEP-NC machining and measurement file is shown and in another box, the simulated measurements are presented. This simulator simulates the measurement results using the system deviation as 0.1 and standard deviation as 0.001 for the positional axial deviations for manufactured parts. There are 100 measurement results obtained for the probing operation of the four hole features.

In this research, the number of measurements has been chosen as 100 so that enough measurement results are obtained for performing the compensation methodology and obtaining the compensated parameters. These 100 measurement results signify the results obtained for feature placement locations for 100 manufactured parts. The main motive in obtaining higher number of measurement results is to have confidence in the results which would be sufficient for carrying out the compensation strategy. However, there has not been any methodology developed in the literature which suggests the appropriate number of measurements needed to obtain confidence in the results. Generally, in the production plants, this number depends on the time constraints and material availability constraints and accordingly measurements are obtained for manual interpretation of results and subsequently providing the feedback parameters. With the development of this simulation methodology for measurement results for feature placement locations for prismatic parts, more number of measurement results can be obtained which can provide more confidence in the results for performing compensation methodologies. This simulator generates 100 updated STEP-NC process plan files with inspection results which are stored in another location on the computer. One of these updated files is shown in Figure 11.

```

Updated STEP-NC Compliant Machining and Measurement Process Plan File 97 - Notepad
File Edit Format View Help
#80=PLANE('hole depth surface',#81);
#81=AXIS2_PLACEMENT_3D('Axis for Placement for Hole Depth',#82,#83,#84);
#82=CARTESIAN_POINT('point for Placement for Hole Depth',(0,0,0,-20,0));
#83=DIRECTION('axis direction for Placement for Hole Depth',(0,0,0,1,0));
#84=DIRECTION('reference direction for Placement for Hole Depth',(1,0,0,0,0));
#85=TOLERANCED_LENGTH_MEASURE(8,0,$);
#86=THROUGH_BOTTOM_CONDITION();
#87=PROBING_WORKINGSTEP('hole1',#88,$,#89,(#91));
#88=PLANE('security plane',$);
#89=PROBING_OPERATION('probing round hole axial position',$,#90,$);
#90=PROBING_STRATEGY('null');
#91=TOLERANCED_POSE_ITEM('axial position',#92,#9,#98);
#92=INSPECTION_RESULT(#93,$,$);
#93=POSE('measured position',#94);
#94=AXIS2_PLACEMENT_3D('Axis for Placement for Hole',#95,#96,#97);
#95=CARTESIAN_POINT('point for Placement for Hole',(15.092,15.099,0,0));
#96=DIRECTION('axis direction for Placement for Hole',(0,0,0,1,0));
#97=DIRECTION('reference direction for Placement for Hole',(1,0,0,0,0));
#98=POSITION_TOLERANCE(0.1,());
#99=PROBING_WORKINGSTEP('hole2',#88,$,#100,(#102));
#100=PROBING_OPERATION('probing round hole axial position',$,#101,$);
#101=PROBING_STRATEGY('null');
#102=TOLERANCED_POSE_ITEM('axial position',#103,#36,#109);
#103=INSPECTION_RESULT(#104,$,$);
#104=POSE('measured position',#105);
#105=AXIS2_PLACEMENT_3D('Axis for Placement for Hole',#106,#107,#108);
#106=CARTESIAN_POINT('point for Placement for Hole',(15.107,135.106,0,0));
#107=DIRECTION('axis direction for Placement for Hole',(0,0,0,1,0));
#108=DIRECTION('reference direction for Placement for Hole',(1,0,0,0,0));
#109=PROBING_WORKINGSTEP('hole3',#88,$,#111,(#113));
#111=PROBING_OPERATION('probing round hole axial position',$,#112,$);
#112=PROBING_STRATEGY('null');
#113=TOLERANCED_POSE_ITEM('axial position',#114,#55,#120);
#114=INSPECTION_RESULT(#115,$,$);
#115=POSE('measured position',#116);
#116=AXIS2_PLACEMENT_3D('Axis for Placement for Hole',#117,#118,#119);
#117=CARTESIAN_POINT('point for Placement for Hole',(135.11,135.101,0,0));
#118=DIRECTION('axis direction for Placement for Hole',(0,0,0,1,0));
#119=DIRECTION('reference direction for Placement for Hole',(1,0,0,0,0));
#120=POSITION_TOLERANCE(0.3,());
#121=PROBING_WORKINGSTEP('hole4',#88,$,#122,(#124));
#122=PROBING_OPERATION('probing round hole axial position',$,#123,$);
#123=PROBING_STRATEGY('null');
#124=TOLERANCED_POSE_ITEM('axial position',#125,#74,#131);
#125=INSPECTION_RESULT(#126,$,$);
#126=POSE('measured position',#127);
#127=AXIS2_PLACEMENT_3D('Axis for Placement for Hole',#128,#129,#130);
#128=CARTESIAN_POINT('point for Placement for Hole',(135.103,15.083,0,0));
#129=DIRECTION('axis direction for Placement for Hole',(0,0,0,1,0));
#130=DIRECTION('reference direction for Placement for Hole',(1,0,0,0,0));
#131=POSITION_TOLERANCE(0.4,());

```

Fig. 11. STEP-NC compliant process plan file updated with measurement results

These 100 simulated STEP-NC files embedded with inspection results are read by the STEP-NC compliant compensator. For the undertaken case study, the nominal (denoted by N followed by a suffix for the feature number) and mean of the measured values (denoted by M) are obtained as: [N1 (15.0, 15.0) and M1 (15.009, 14.008)], [N2 (15.0, 135.0) and M2 (14.003, 134.098)], [N3 (135.0, 135.0) and M3 (135.092, 135.094)] [N4 (135.0, 15.0) and M4 (135.096, 14.099)].

A decision making algorithm has been developed which provide the compensated placement parameters for the hole feature locations. The analysis is based on the nominal feature locations and simulated feature locations. This algorithm is dependent on an optimisation algorithm where total errors produced for the deviation in the simulated feature locations has been minimised. The compensated parameters (denoted by C followed by a suffix for feature number) for the four hole features are obtained as follows: [C1 (14.97, 14.89)], [C2 (15.07, 134.98)], [C3 (135.02, 134.93)], [C4 (134.09, 14.92)].

Standardised feedback in the form of compensated feature placement coordinates are fed-back into the manufacturing CAx chain. The output of process control system is a standardised manufacturing information file which essentially is a compensated STEP-NC compliant machining and measurement file.



## 9 Summary

Information models for machine tool process control have been presented in this paper. STEP-NC standards have been utilised to represent the information in manufacturing CAX chain. It has been shown that STEP-NC standards help in preserving the manufacturing context throughout the manufacturing process chain. Based on the information models, measurement results for a particular inspection item for a feature are linked with its design and machining process information.

An encoding mechanism for the machining and inspection objects has also been described in this research which becomes the building blocks for developing the computational platform of machine tool process control system. This computation prototype has been realised in a simulated environment using a prismatic case component. A mechanism for process control by providing the compensation parameters to a machining and measurement process plan has been described.

## Acknowledgements

The work reported in this paper has been supported by a number of grants for Engineering and Physical Sciences Research Council (EPSRC), involving a large number of industrial collaborators. In particular, current research is being undertaken as part of the EPSRC Innovative design and Manufacturing Research Centre at the University of Bath (reference GR/R67507/01). The authors gratefully express their thanks for the advice and support of all concerned.

## References

- DMIS 3.0: Dimensional measuring interface standard. ANSI/CAM-I101.1 (1995)
- ISO 14649-219: Product data representation and exchange: Application protocol: Dimensional inspection information exchange. ISO (2005)
- DMIS 4.0: Dimensional measuring interface standard. ANSI/CAM-I104.0 (2001)
- DML 2.0: Dimensional markup language (2004)
- Horst, J.: Meeting notes for June 21, I++ DME implementer's conference call. NIST (2004)
- ISO 14649-16 WD: Industrial automation systems and integration — physical device control — data model for computerized numerical controllers — part 16: Data for touch probing based inspection. ISO (2004)
- ISO 10303-514: Industrial automation systems and integration – product data representation and exchange – part 514: Application interpreted construct: Advanced boundary representation. ISO (1999)
- ISO 10303-224: Industrial automation systems and integration — product data representation and exchange, part 224: Application protocol: Mechanical product definition for process plans using machining features ISO (2000)
- Kumar, S., Nassehi, A., Newman, S.T., Allen, R.D., Tiwari, M.K.: Process control in CNC manufacturing for discrete components: A STEP-NC compliant framework. *Robotics and Computer-Integrated Manufacturing* 23(6), 667–676 (2007)
- Kramer, T.R.: Analysis of standards needs for automated metrology. Presentation, Knowledge Systems Group NIST (2001)

- Nassehi, A.: The realisation of CAD/CAM/CNC interoperability in prismatic part manufacturing. Thesis (PhD). University of Bath, Bath, UK (2007)
- Schafer, J.: Dimensional markup language, DML General Presentation (2004)
- Vorburger, T.: Dimensional inspection information exchange SIMA project description, NIST (2000)
- Vichare, P., Nassehi, A., Kumar, S., Newman, S.T.: A unified manufacturing resource model for representation of CNC machining systems. In: Proceedings of 18th International Conference on Flexible Automation (FAIM), Skovde, Sweden (June 2008)