

## A hybrid approach to automatic generation of NC programs

**M. Tolouei-Rad \***, **G. Payeganeh**

Manufacturing Engineering Department, Shahid Rajaei University,  
PO Box 16785-163, Tehran, Iran

\* Corresponding author: E-mail address: mtrad@srttu.edu

Received 15.11.2005; accepted in revised form 31.12.2005

### Methodology of research

#### ABSTRACT

**Purpose:** This paper describes AGNCP, an intelligent system for integrating commercial CAD and CAM systems for 2.5D milling operations at a low cost.

**Design/methodology/approach:** It deals with different machining problems with the aid of two expert systems. It recognizes machining features, determines required machining process plans, cutting tools and parameters necessary for generation of NC programs.

**Findings:** The system deals with different machining problems with the aid of two expert systems. The first communicates with CAD system for recognizing machining features. It is developed in LISP as machining features can be properly represented by LISP codes is ideal for manipulating lists and input data. The second expert system requires extensive communications with several databases for retrieving tooling and machining information and VP-Expert shell was found to be the most suitable package to perform this task.

**Research limitations/implications:** 2.5D milling covers a wide range of operations. However, work is in progress cover 3D milling operations. The system can also be modified to be used for other activities such as turning, flame cutting, electro discharge machining (EDM), punching, etc.

**Practical implications:** Use of AGNCP resulted in improved efficiency, noticeable time savings, and elimination of the need for expert process planners.

**Originality/value:** The paper describes a method for eliminating the need for extensive user intervention for CAD/CAM integration.

**Keywords:** Analysis and modeling; CAD/CAM; Expert systems; Milling; Process planning

### 1. Introduction

With great advances made in numerical control (NC) programming in recent years, it is not difficult to imagine that the entire logic of the part programming process can be captured and put on the computer. This would permit NC programming to be accomplished automatically by computer without human interface.

There have been numerous reports in recent years on developing automated systems for NC program generation. Of these many use automatic feature recognition from CSG/B-Rep/wire frame CAD models as a basis for identifying machining features and subsequent NC program generation. Examples include rule based [1] and syntactic pattern based [2] recognition.

Development of domain specific feature modeling systems has also been reported. Examples are OMEGA [3], PRISPLAN [4], CFACA [5], VITool [6], IFPP [7] and multiresolution CSG algorithm [8]. OMEGA uses production rules to define operation sequences that are then subsequently grouped into set-ups based on the nature of the tolerances. PRISPLAN, CFADA and IFPP focus on generating NC programs for machining centers.

Thakar *et al.* [9] developed an integrated process planning and part programming system for rotational parts. In this system some information such as cutting fluid and coordinates of the starting point of an operation must be provided manually by the user. EXCAP [10] was developed at UMIST and is capable of generating NC programs for turned components. A two

dimensional CAD model is translated to the format required by the knowledge based process planning system. Jackson and Mittal [11] developed another system capable of generating NC part programs for two-dimensional laser-cutting applications. Opas and Mantyla [12] developed another NC program generator as part of a feature-based process planning system. The system generates NC codes from the sequenced process plans. Hinduja and Sandiford [13] developed developed system for optimum determination of pair of tools for stock removal and finishing in milling. Bidanda and Billo [14] developed a system for generation of NC programs for producing countersink cutting tools. Developments of similar systems have also been reported [15–19].

Systems developed vary in their capabilities in terms of strategies for part geometry input and process planning stages such as operation extraction and sequencing, machining parameter and tool selection and NC program generation. Although the systems described are quite valuable in the domain of NC program generation, most of them are application specific and still need extensive user intervention for determining crucial manufacturing parameters such as cutting tools, speeds, feed rates, cutting depths, etc. Most systems described face with limitations such as:

- Handle only geometric data, and technological data must still manually entered by the user;
- Apply to limited applications that can be represented in a two dimensional basis, such as turning, laser and flame cutting, and punching operations;
- Operate on dedicated workstations or higher-ordered systems requiring high initial capital cost.

Furthermore, much commercial NC programming software are semi-automatic requiring several inputs from the user for feature identification, tool selection, tool path generation, etc. As a result, a full CAD/ CAM integration has not yet been achieved and this paper reports an attempt to go one step closer to this goal.

This paper describes development of a system, AGNCP, which significantly reduces the need for user intervention for generating NC programs. It extracts machining features from the geometric data of the CAD system, determines required machining process plan, cutting tools and machining parameters, and provides all necessary information for automatic generation of NC programs. AGNCP is not bound to be used in conjunction with specific CAD and CAM systems and can be used as a universal system for integrating many commercial CAD and CAM systems.

## 2. System architecture

AGNCP has been developed using a hybrid expert system approach, as shown in Figure 1. It is composed of a CAD system, a CAM system, and two expert systems linked together. Expert system 1 is devoted to recognition of machining feature. Expert System 2 is developed for determining machining sequence plans, cutting tools and machining parameters. The reason for developing two different expert systems is that each of them is ideal for its own function. Expert system 1 must communicate

with CAD system and recognise machining features. Therefore, it is developed with LISP programming language since features can be properly presented by LISP codes. Also LISP is ideal for manipulating lists and input data. Expert System 2 requires extensive communications with several databases for retrieving tooling and machining information, and VP-Expert shell was found to be the most suitable package to perform this task.

## 3. Product design

The integration procedure begins with designing the required product using a CAD system. Any CAD system capable of creating proper data exchange files can be used for this purpose. STEP is the common standard for data exchange in conventional CAD/CAM systems and almost all CAD systems available today are capable of generating STEP files. In this work a number of PC-based CAD systems such as AutoCAD and CADDSMAN have been used. Once product design is completed, its STEP file is created by the CAD system. This file contains all geometric data of the design.

## 4. Feature recognition

The first step towards automated NC program generation is automatic interpretation of design data. Feature recognition approach has been introduced in recent years to link CAD and computer aided process planning (CAPP). Large number of papers has been published on the feature recognition approach and a paper published by Allada and Anand [20] gives a comprehensive review on this approach and its status. Using this approach, many attempts have been made to automate different manufacturing related tasks, mainly CAPP functions. Many researchers prefer to use automatic feature recognition since their ultimate task has been to reduce human interface as much as possible. Examples are systems reported in references [21–24]. Also, an overview of automatic feature recognition techniques for computer-aided process planning can be found in the paper published by Subrahmanyam and Wozny [25]. Accordingly, in this work feature recognition approach has been used as a means of identifying machining concepts.

Expert system 1 is developed for the recognition of machining features, as mentioned earlier. Inputs to Expert System 1 are geometric data of the product restored in a data exchange file. Since data exchange files created by the CAD systems are sequential, retrieving geometric data from these files is inconvenient. As a result, Expert System 1 cannot use geometric data of the data exchange files directly. To deal with this problem, a complementary program written in LISP has been included in Expert System 1. The complementary program ignores redundant information of the data exchange file which are not necessary for this system and restores its geometric data in an input file in a suitable format. These geometric data are then used for recognition of the machining features of the design. To accomplish this task, Expert System 1 decomposes complex machining features into simple features tries to recognize them first. Simple features refer to those machining features that can be

machined by a single tool in a single operation. These features include pockets, slots, holes, etc. To identify simple features, Expert System I uses feature recognition knowledge restored in Rule Base I in the form of logical *if-then* rules. Each simple feature can be recognized by firing appropriate rules on the basis of forward chaining. Any complex feature can be represented by a combination of the simple features. Therefore, complex features will be identified once all simple features have been recognized.

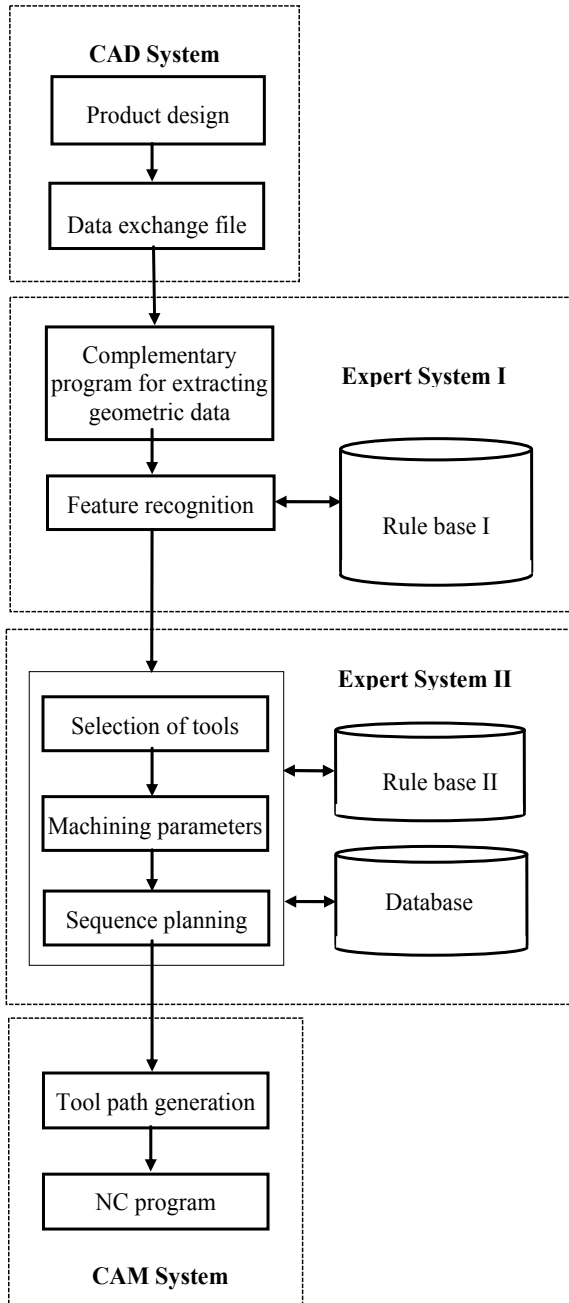

Fig. 1. General overview of AGNCP.

Rule 114 is a sample rule of Expert System I for recognition of machining features. This rule determines whether there is any through hole in the complex feature:

**Rule 114**  
*if* the complex feature has hole(s) (i.e.  $r \geq 1$ );  
*and* Euler's formula has been applied to the feature;  
*and*  $g \geq 1$ ;  
*then* complex feature possesses  $g$  through hole(s);  
*else* the hole(s) is (are) blind.

where Euler's formula for features can be represented by:

$$v + f - e = (s - g) + r \quad (1)$$

and where  $v$ ,  $e$ ,  $f$  are the number of vertices, edges, and faces of the simple feature, respectively.  $s$  is the number of the shell contained in the complex feature.  $g$  represents the number of through holes in the complex feature. If  $g$  is equal to or greater than one, then the complex feature possesses  $g$  through holes; otherwise, there is no through hole in the complex feature. In the above formula  $r$  is the number of rings that the complex feature has and it can be defined by:

$$r = N_{rings} = N_{loops} - N_{faces} \quad (2)$$

It is noteworthy that in Euler's formula and accordingly in Rule 114, *hole* refers to any depressive simple feature such as hole, pocket and so on.

### 5. Design Representation Scheme (DRS)

Upon recognition of machining features, they must be represented in a form suitable for computer programs in order to be used for process planning and NC program generation purposes. To accomplish this task, a Design Representation Scheme (DRS) has been developed which gives a complete and unambiguous representation of the product and its machining features. DRS represents all mechanical and geometric specifications of the product by a group of LISP codes. It represents mechanical components as a related set of features. Since mechanical data of the workpiece can not be obtained from the data provided by the CAD system, the system obtains these data from the user through a dialogue. User is requested to enter these data by selecting from the menus provided. Following is the format used by DRS for representing mechanical components:

```
(setq product_name
  (
    (mechanical_data)
    (material m)
    (hardness h)
    (condition c)
    (geometric_data)
    (simple_feature_1)
    (simple_feature_2)
    ....
    (simple_feature_n)
  )
)
```

where *setq* is a special form that assigns the value to a variable in LISP, and the name of the list should be written between *setq* and the apostrophe. Mechanical data of the workpiece such as its material, hardness and condition (e.g. normalized, hot rolled, etc.) are respectively represented by parameters *m*, *h* and *c*. Geometric data of the product are represented in the same way. Complex features will be represented as a set of simple features. Geometric and topological information of each simple feature will be represented in a separate list as shown below:

$$(SF_i \text{ Type } D_1 T_{11} T_{12} \dots D_n T_{n1} T_{n2} M_i)$$

In the above list,  $SF_i$  and Type respectively represent the number and the type of the simple feature.  $D_1$  to  $D_n$  represent dimensions of the simple feature in a pre-defined order. It should be noted that the number of dimensions for each simple feature depends upon its type since different features may require different number of dimensions. Each dimension is associated with its tolerance values,  $T_{11}$  and  $T_{12}$ , respectively representing the lower and upper tolerance values. If any tolerance value is not given, the corresponding element will be substituted by nil. The last element of the list,  $M_i$ , is a pointer to the transformation matrix representing position and orientation of the simple feature with respect to the original or world co-ordinate system. Each component has a world co-ordinate system (WCS) and each simple feature has a local co-ordinate system (LCS) that is defined with respect to the WCS. Thus, a 3 X 4 transformation matrix as can represent the position and orientation of each simple feature with respect to the WCS:

$$M_i = \begin{bmatrix} x_x & y_x & z_x & p_x \\ x_y & y_y & z_y & p_y \\ x_z & y_z & z_z & p_z \end{bmatrix} \quad (3)$$

where X, Y and Z vectors represents orientation of the corresponding LCS respectively in x, y and z directions, and vector P represents its position. Thus, each transformation matrix can be restored in a 13 member list as:

$$(M_i \ x_x \ x_y \ x_z \ y_x \ y_y \ y_z \ z_x \ z_y \ z_z) \quad (4)$$

## 6. Process planning

Process planning has been defined, as the activity that translates part design specifications from an engineering drawing into the manufacturing operation instructions required converting a part from a rough to finished state. Expert System 2 has been developed for machining process planning in the system developed. This involves determination of required machining operations for producing each simple feature, determination of appropriate sequence for performing these operations, and selection of cutting tools and machining parameters for each operation.

Expert System 2 has employed a group of rules for determining required machining operations through comparing dimensions of the finished part and the blank. For instance,

peripheral end milling will be employed if length and width of the blank is greater than those of the required product. Accordingly, the required machining operations for producing each individual simple feature will be determined by firing appropriate rules from the Rule Base 2. It is noteworthy that some features will be produced automatically upon machining other features, e.g. islands will be produced automatically upon machining corresponding pockets, however, sometimes a finishing operation is still required.

### 6.1. Machining parameters

There are so many parameters influencing the result of a milling operation. These variables include the size and shape of workpiece, properties of the workpiece material, kind of machining operation, type of cutting tool and machine, rigidity of setup, production rate, tolerances and surface finish requirements. Cutting speed and feed rate have the greatest effect on productivity. These two parameters together with the width and depth of cut determine metal removal rate.

In this work, an attempt has been made to establish essential machining parameters to perform milling operations efficiently. Expert System 2 receives mechanical of the workpiece material and geometric data of the operations in the form of LISP codes explained above as input data. Based on these data, it determines required machining parameters without any user intervention. To accomplish this task, it uses information of available cutting tools and recommended machining parameters restored in a number of databases. These parameters include appropriate cutting tools, power requirements, cutting speeds, feed rates, depths of cut and cutting fluid for all machining steps. These parameters will be used by the CAM system for generation of NC program.

The inference engine is the heart of any expert system. It is the mechanism used to solve problems, and to find goals. The inference engine accomplishes by managing and manipulating the rule base. Accordingly, inference engine plays a central role in Expert System 2. It uses backward chaining where it actively integrates expertise stored in the rule base in the form well known *if-then* rules with tooling and machining information restored in databases. In order to reach its goal, inference engine systematically searches for new values to assign to appropriate variables that are present in the rule base. Therefore, it has the capability of adding to the known store of knowledge.

Use of databases in Expert System 2 brings up the advantage of shorter running time for the system compared with conventional applications of expert systems. This advantage is due to the existence of a limited number of expertise rules restored in the Rule Base 2. Updating the information stored in databases can be done either through a dialogue with user or through direct access of user to databases. Sample rules from the Rule Base 2 are:

#### Rule 210

*if* operation is end milling,

*then* the number of teeth of the tool can be determined by:

$$z = \frac{12.6d \cos H}{d + 4a} \quad (5)$$

where  $z$  represents the number of cutting teeth;  $d$  is tool diameter;  $a$  is depth of cut; and  $H$  stands for the helix angle of the tool.

**Rule 222**

*if* a pocket is to be machined;  
*and* there is island(s) inside the pocket;  
*then* tool diameter is less than or equal to the pocket's fillet radius;  
*and* tool diameter is less than or equal to the minimum distance between the pocket's wall and all islands;  
*and* tool diameter is less than or equal to the minimum distance between all islands.

**6.2. Machining srquence**

Once all machining operations and parameters have been determined, Expert system 2 determines the machining sequence plan by firing a number of rules. To accomplish this task, it arranges machining operations of individual simple features in the right order such that the number of necessary tool changes becomes minimal. To accomplish this task, an operation matrix will be developed which represents bilateral precedence between machining operations. In this matrix each operation possesses a row and a column as shown below:

Operations	1	2	3	...	4
1	$a_{11}$	$a_{12}$	$a_{13}$	...	$a_{1j}$
2	$a_{21}$	$a_{22}$	$a_{23}$	...	$a_{2j}$
3	$a_{31}$	$a_{32}$	$a_{33}$	...	$a_{3j}$
...	...	...	...	...	...
4	$a_{41}$	$a_{42}$	$a_{43}$	...	$a_{4j}$

In this matrix, each row and column belongs to an operation. The arrangement of the operation numbers in rows and columns is identical. Each element in the operation matrix could have a value of either 1, -1 or 0. The number located in intersection of a row with a column represents the precedence of the operation of the corresponding row to the operation of corresponding column. For example, if intersection of operation A in rows with operation B in columns is 1, then A must be performed before B. Similarly, if the intersecting number is -1, B must be performed before A. If the intersecting number is 0, none of the operations has precedence to the other one, and any of them can be performed first. The sum of all elements in the matrix becomes zero. It should be noted that when there is any -1 element in the corresponding row of any operation, that operation can not be performed since: (a) still there is no tool access to machine that feature, or (b) a feature which is the reference for machining that feature is not yet produced. At this stage, an index of priority (IOP) will be determined for each operation that determines the general precedence of that operation with respect to all operations. This number for each feature is the sum of all elements in the corresponding row of the feature in the operation matrix (i.e.  $IOP_i = a_{i1} + a_{i2} + \dots + a_{ij}$ ). The higher the IOP, the earlier the operation must be performed.

**7. NC program generation**

All existing CAM systems need similar machining data for NC program generation; but in different formats. For example, SmartCAM reads these data from an ASCII file with "jsf" extension and CADDSMAN uses a binary file to restore machining data with "ncl" Extension. When all machining parameters and tools are determined, AGNCP uses resulted information to develop the machining data file (MDF) in order to be used by CAM system for generation of NC part program. MDF provides all necessary technological data for each step of machining process which are required for NC program generation. Required geometric data for CAM system can be obtained from STEP file created by the CAD system. Then, CAM system uses provided data by the system and displays tool paths for each step of machining operation. User can either accept the displayed tool paths or modify them. Then, the CAM system generates required NC program for producing the product and restores it in an output file. Finally, an NC machine uses generated NC program and produces the product. The operating flowchart of AGNCP is shown in Figure 2.

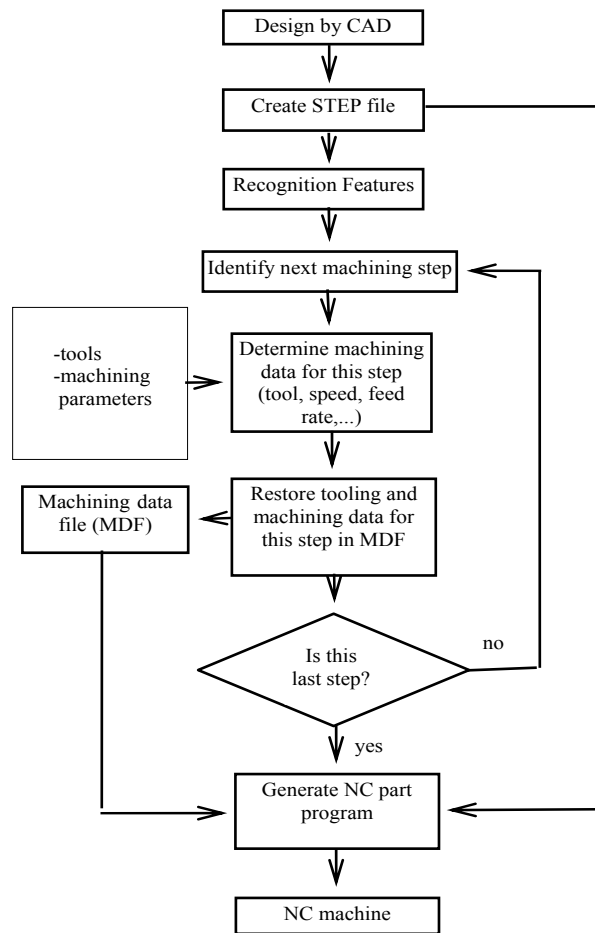

Fig. 2. Operating flowchart of AGNCP.

## 8. Case study

The sample part shown in Figure 3 has been processed by the system. It has been designed by CADDSMAN under the name "sample part". Once the design is complete its STEP file was generated. AGNCP asked the user for mechanical data using menus provided. It then extracted required geometric data from the generated STEP file and introduced appropriate dimensions for the blank. In order to recognize the complex feature, AGNCP decomposed it into 40 simple features of various types. These included 2 blocks, 4 notches, 10 countersink holes, 2 islands, etc. The sample part or the complex feature was defined in a world X, Y and Z co-ordinate system (WCS). The system also defined a local x, y and z coordinate system (LCS) for each simple feature. Using transformation matrices the position of each LCS was specified with respect to the WCS. In other words, position of each simple feature was defined with respect to the blank. Once feature recognition has been completed, AGNCP represents all specifications of the design in LISP codes.

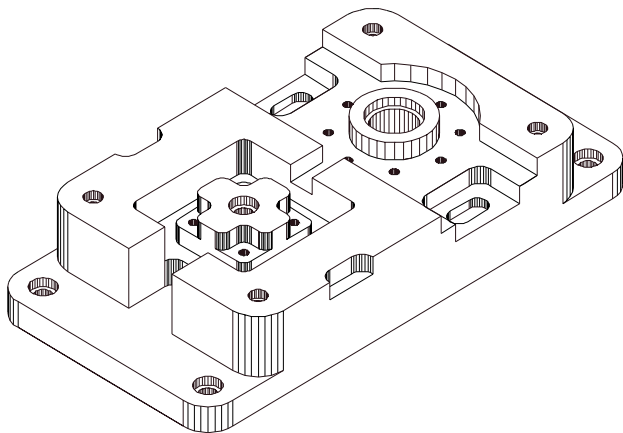

Fig. 3. The sample part.

Expert System 2 received above codes as its input data and determined appropriate process plan for machining the product. Then AGNCP used output information of Expert system 2 and developed machining data file (MDF) which contains all machining and tooling data required for generating NC program. Since SmartCAM has been used here, resulted MDF saved in a format suitable for SmartCAM. The CAM system used geometric data of STEP file generated by the CAD system together with technological data restored in MDF and generated the toolpath for each step of operation. The whole process from the start of modelling to generating NC program took only 37 minutes. This gives a considerable save of time in comparison with hours required in ordinary use of commercial CAD/CAM systems.

## 9. Conclusions

AGNCP is a system capable of automatic NC program generation through integrating commercially available CAD and CAM systems at a low cost. The system deals with different

machining problems with the aid of two expert systems. Use of AGNCP would result in improved efficiency, noticeable time savings, and elimination of the need for expert process planners. At present it can be used to generate programs for performing 2.5D milling operations covering a wide range of milling applications. However, NC milling is not limited to 2.5D operations and there are varieties of parts which involve 3D milling operations. Since geometric data of 2.5D and 3D models can be extracted from the data exchange files, work is in progress to further develop the system for 3D milling operations. In addition, the system can be modified to be used for other NC activities such as turning, flame cutting, electro discharge machining (EDM), punching, etc.

## References

- [1] J.H. Vandenbrande and A.A.G. Requicha, 1993, Spatial reasoning for the automatic recognition of machinable features in solid models, *IEEE Pattern analysis and machine intelligence*, 15 (12), 1269-1285.
- [2] V.S Kulkarni and S.S Pande, 1995, A system for automatic extraction 3D part features using syntactic pattern recognition techniques, *International Journal of Production Research*, 33 (6), 1569-1580.
- [3] L. Sabomin and F. Villeneuve, 1996, OMEGA, An expert CAD system, *Advances in Engineering software*, 25 (1), 51-59.
- [4] R.B Karadkar and S.S Pande, 1996, Feature based automatic CNC code generation for prismatic parts, *Computers in Industry*, 28 (2) 137-150.
- [5] X. Liu, 2000, CFACA: A component framework for feature-based design and process planning, *Computer Aided Design*, 32 (7), 397-408.
- [6] P.G Maropoulos, R.P Paker, and K.Y.G Paramor, 2000, Integration of tool selection with design; Part 1: Feature creation and selection of operations and tools, *Journal of materials processing technology*, 107 (13), 127-134.
- [7] L. Patil and S.S. Pande, 2002, An intelligent feature process planning system for prismatic parts, *International Journal of Production Research*, 40 (17), 4431-4447.
- [8] L. Peled, A. Fischer, and M. Shpitalni, Multiresolution Representation of 2D CSG Models, *Annals of the CIRP 2004*, 53 (1) p. 143.
- [9] G. Thakar, K. Shanker and V.K. Jain, 1993, An integrated process planning and NC part programming system for rotational components, *Computers in Industry*, 21, 341-357.
- [10] M. Kalta and B.J. Davies, 1994, STEP pre-processor to integrate CAD and CAPP for turned components, *Int. J. Adv. Manuf. Technol.*, 9 (5) 291-304.
- [11] S.D. Jackson and R.O. Mittal, 1993, Automatic generation of 2-axis laser-cutter NC machine program and path planning from CAD, *Computers in Industry*, 21, 223-231.
- [12] J. Opas and M. Mantyla, 1994, Techniques for automatic part program generation, *Advances in Engineering Software*, 20 (2 & 3), 141-155.
- [13] S. Hinduja and D. Sandiford, An Optimum Two-tool Solution for Milling 2½D Features from Technological and Geometric Viewpoints, *CIRP Annals 2004*, 53 (1) p. 77.

- [14] B. Bidanda and R.E. Billo, 1996, Parametric design and NC code generation of countersink cutting tools, *International Journal of Computer Integrated Manufacturing*, 9 (2) 105-112.
- [15] F. Kimura, H. Ariyoshi, H. Ishikawa, Y. Naruko, and H. Yamato, Capturing Expert Knowledge for Supporting Design and Manufacturing of Injection Molds, *CIRP Annals* 2004, 53 (1) p. 147.
- [16] W. Eversheim, H. Rozenfled, W. Botchler and R. Graessler, 1995, A methodology for an integrated design and process planning based on a concurrent engineering reference model, *Annals of the CIRP*, 44 (1) 403-406.
- [17] J. Huang, T. Wang, L. Wan, X. Zhang and J. Zhou, 1994, Step-based CAD/CAPP/CAM integrated systems: CADMIS, *Engineering Data Management: Integrating the Engineering Enterprise*, ASME Database Symposium, ASME, New York, USA, 155-161.
- [18] Z.D. Zhou, J.D. Zhou, Y.P. Chen, S.K. Ong, A.Y.C. Nee, Geometric Simulation of NC Machining based on STL Models, *CIRP Annals* 2003, 52 (1) p.129.
- [19] S.D. Jackson and R.O. Mittal, 2001, Automatic generation of 2-axis laser-cutter NC machine program and path planning from CAD. *Computers in Industry*, 21, 223-231.
- [20] V. Allada and S. Anand, 1995, Feature-based modelling approaches for integrated manufacturing: state-of-the-art survey and future research directions, *I. J. Computer Integrated Manufacturing*, 8 (6) 411-440.
- [21] S.H. Yeo, 1994, Knowledge-based feature recognizer for machining, *Computer Integrated Manufacturing systems*, 7 (1) 29-37.
- [22] J. Dong and H.R. Parsaei 2004, Design and implementation of a feature-based automated process planning (FBAPP) system, *Computers & Industrial Engineering*, 27 (1-4).
- [23] A. Senthil Kumar, F.K. Salim and A.Y.C. Nee, 1996, Automatic recognition of design and manufacturing features from prismatic parts, *Int. J. Adv. Manuf. Technol.*, 11 (2) 138-145.
- [24] M.Y. Jung and K.H. Lee, 1996, A CAD/CAPP interface for complex rotationally symmetric parts, *Int J Prod. Res.*, 34 (1) 227-251.
- [25] S. Subrahmanyam and M. Wozny, 2003, Overview of automatic feature recognition techniques for computer-aided process planning, *Computers in Industry*, 26 (1) 1-21.