



Robotics 1

Robot components: Proprioceptive sensors

Prof. Alessandro De Luca

DIPARTIMENTO DI INGEGNERIA INFORMATICA
AUTOMATICA E GESTIONALE ANTONIO RUBERTI



SAPIENZA
UNIVERSITÀ DI ROMA

Properties of measurement systems - 1



- **accuracy**

agreement of measured values with a given reference standard (e.g., ideal characteristics)

- **repeatability**

capability of reproducing as output similar measured values over consecutive measurements of the same constant input quantity

- **stability**

capability of keeping the same measuring characteristics over time/temperature (similar to accuracy, but in the long run)



Accuracy and Repeatability

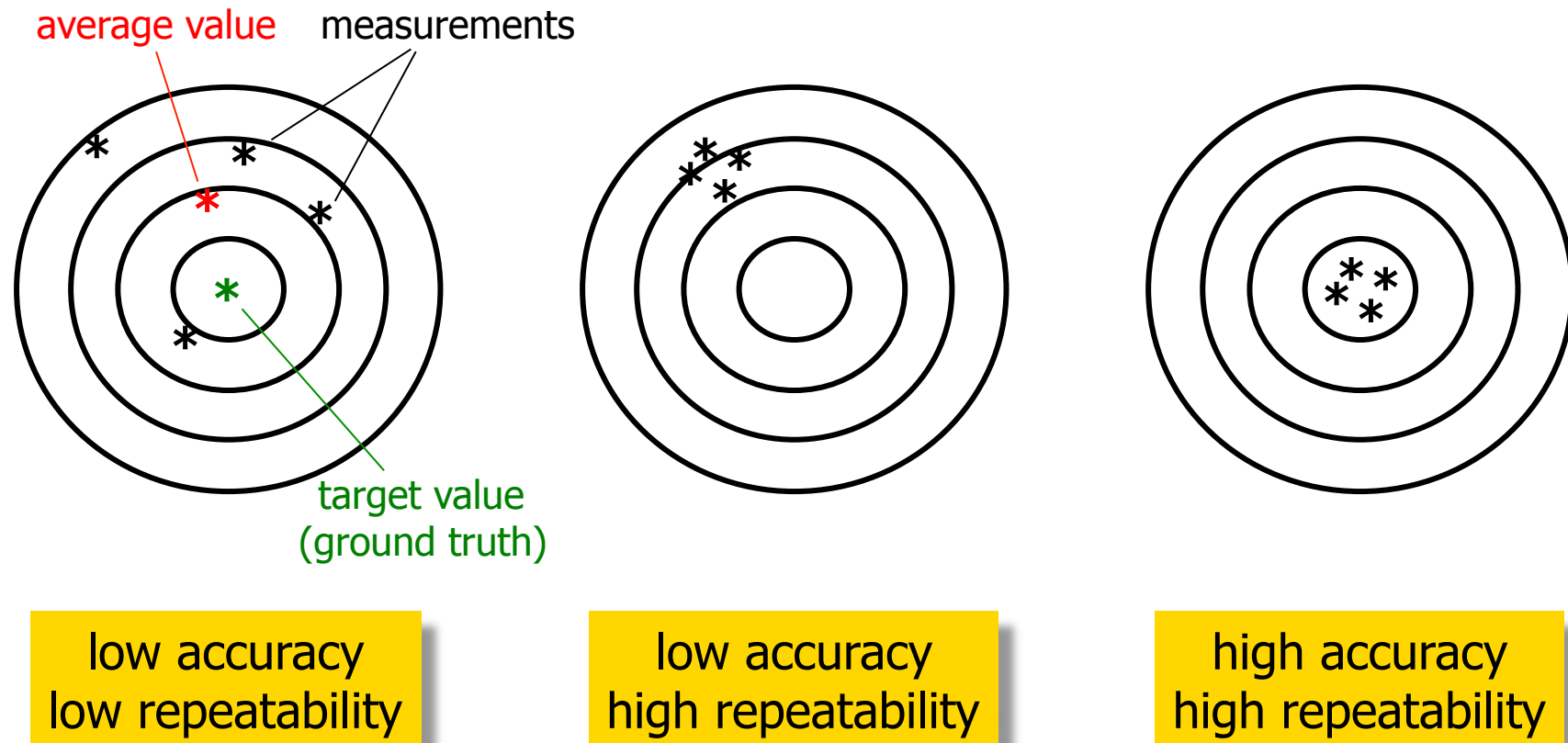

Accuracy and Repeatability in robotics



- **accuracy** is how close a robot can come to a given point in its workspace
 - depends on machining accuracy in construction/assembly of the robot, flexibility effects of the links, gear backlash, payload changes, round-off errors in control computations, ...
 - can be improved by **(kinematic) calibration**
- **repeatability** is how close a robot can return to a previously taught point
 - depends only the robot controller/measurement resolution
- both may vary in different areas of the robot workspace
 - standard ISO 9283 defines conditions for assessing robot performance
 - limited to static situations (recently, interest also in dynamic motion)
 - robot manufacturers usually provide only data on "repeatability"

video



simple test on repeatability of a
Fanuc ArcMate100i robot (1.3 m reach)

Properties of measurement systems - 2



- **linearity** error

maximum deviation of the measured output from the straight line that best fits the real characteristics

- as % of the output (measurement) range

- **offset** error

value of the measured output for zero input

- sometimes not zero after an operation cycle, due to **hysteresis**

- **resolution** error

maximum variation of the input quantity producing no variation of the measured output

- in absolute value or in % of the input range



Linearity, Offset, Resolution

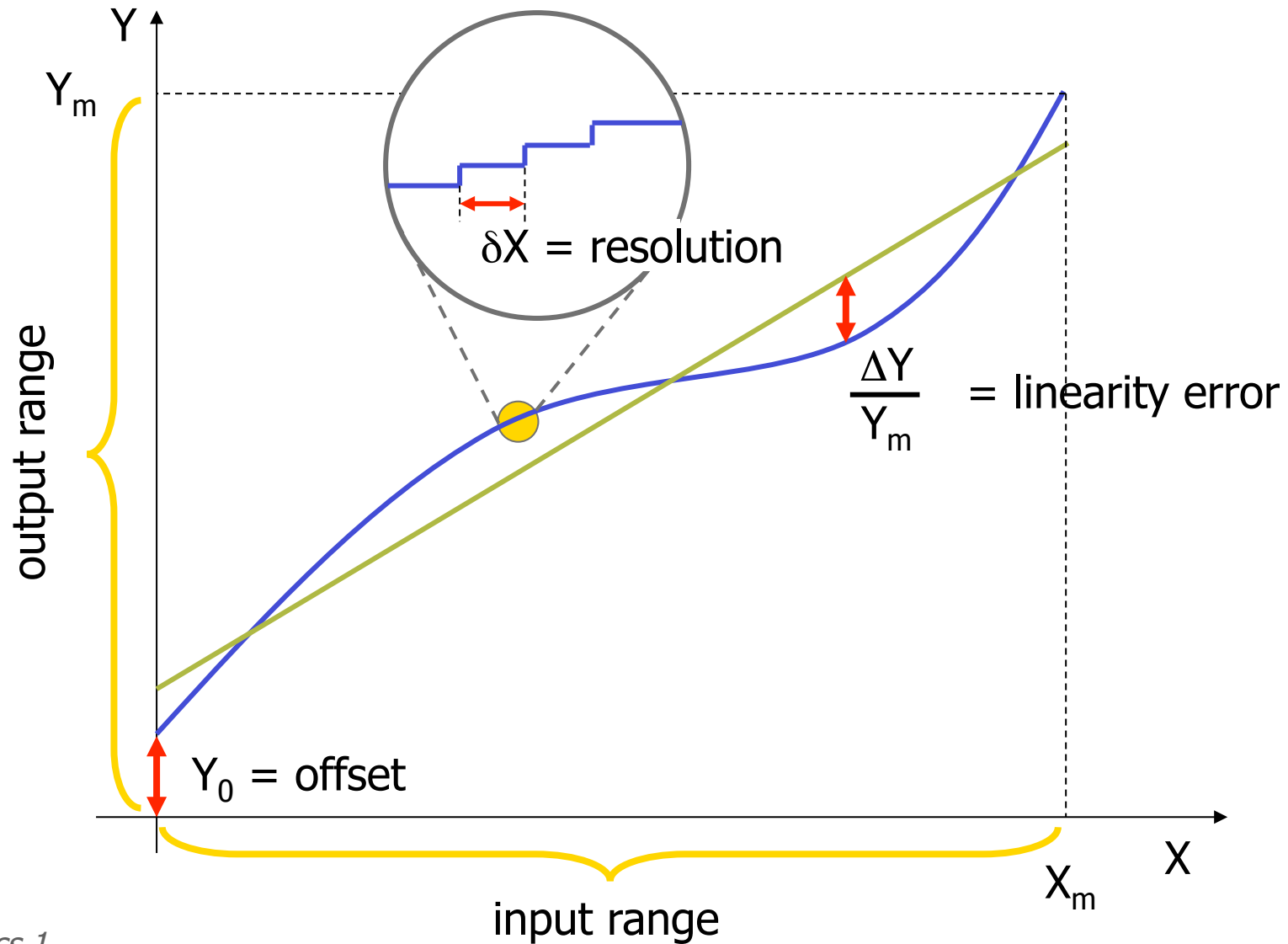

Sensor measurements some non-idealities

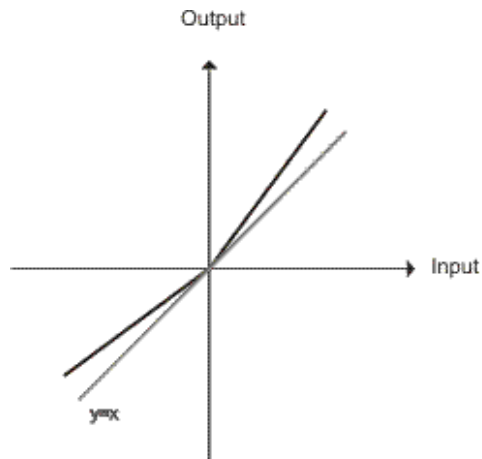

Asymmetry

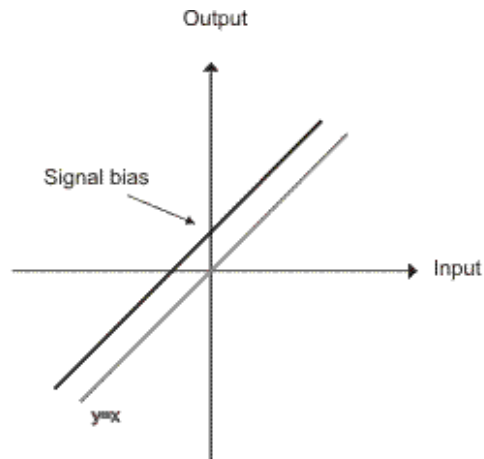

Bias

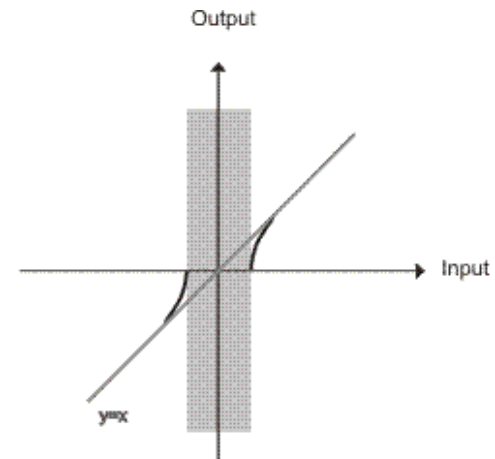

Dead zone

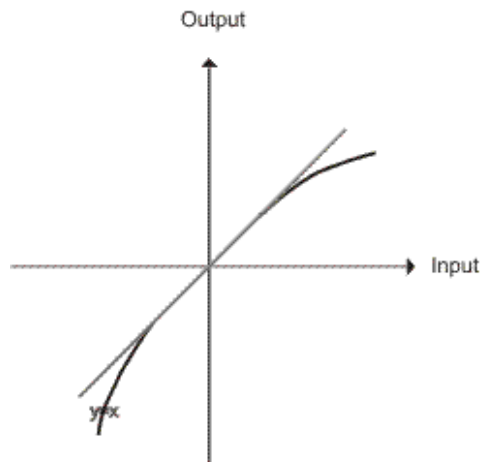

Nonlinearity

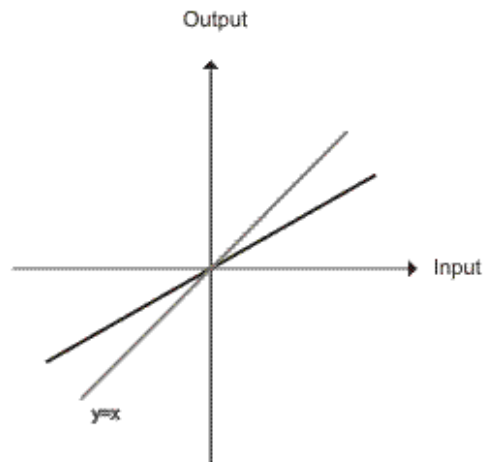

Scaling factor

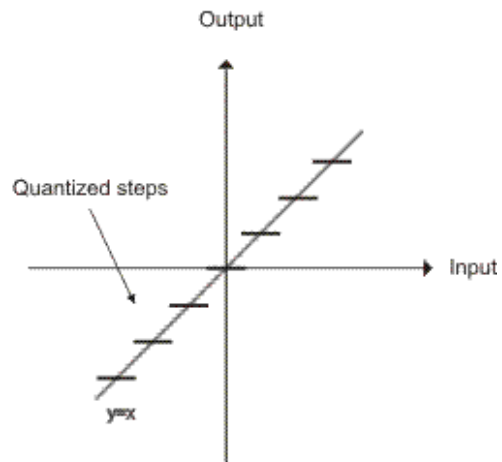

Quantization



Classes of sensors for robots

- **proprioceptive sensors** measure the internal state of the robot (**position** and **velocity** of **joints**, but also **torque** at **joints** or **acceleration** of **links**)
 - kinematic calibration, identification of dynamic parameters, control
- **exteroceptive sensors** measure/characterize robot interaction with the environment, enhancing its autonomy (**forces/torques**, **proximity**, **vision**, but also sensors for sound, smoke, humidity, ...)
 - control of interaction with the environment, obstacle avoidance, localization of mobile robots, navigation in unknown environments



Position sensors

- provide an **electrical signal proportional to the displacement** (linear or angular) of a mechanical part with respect to a reference position
- **linear** displacements: potentiometers, linear variable-differential transformers (LVDT), inductosyns
- **angular** displacements: potentiometers, resolvers, syncros (all analog devices with A/D conversion), **encoders (digital)**

the most used in robotics, since also linear displacements are obtained through rotating motors and suitable transmissions





Absolute encoders

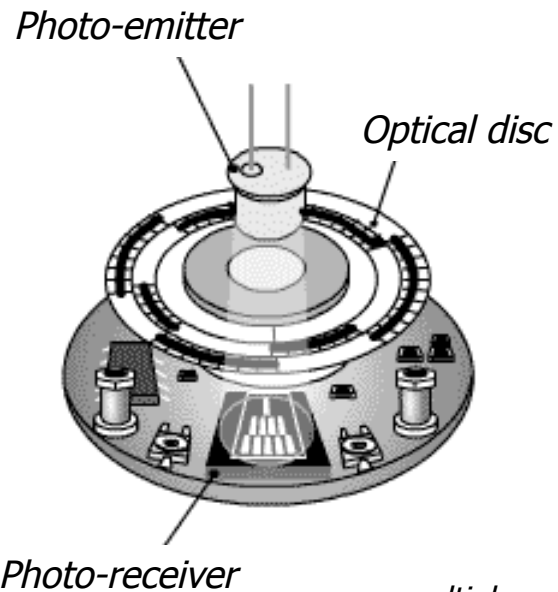

- rotating optical disk, with alternated transparent and opaque sectors on multiple concentric tracks
- (infrared) light beams are emitted by leds and sensed by photo-receivers
- light pulses are converted into electrical pulses, electronically processed and transmitted in output
- **resolution** = $360^\circ/2^{N_t}$
- digital encoding of **absolute** position

$N_t = \# \text{ tracks} = \# \text{ bit}$
(min 12 in robotics)

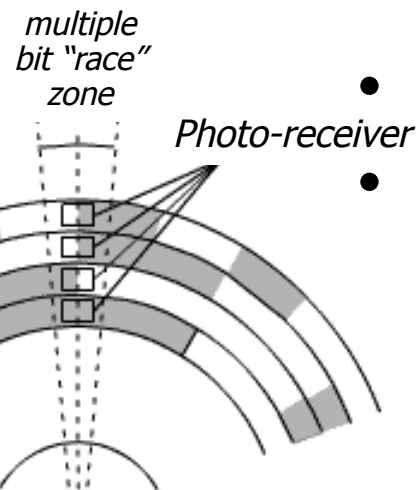

when the optical disk is rotating fast, the use of **binary coding** may lead to (large) reading errors, in correspondence to multiple transitions of bits



Absolute encoding

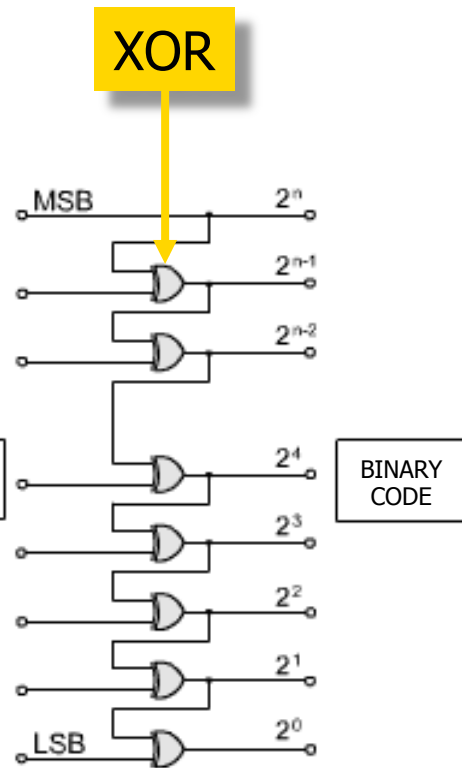
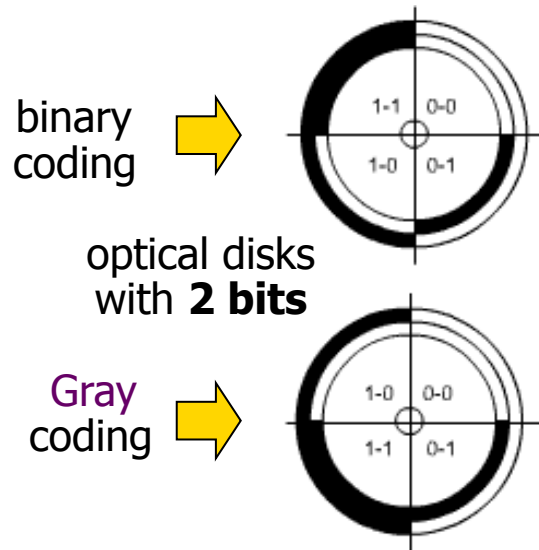

DECIMAL	BINARY	GRAY
0	0000	0000
1	0001	0001
2	0010	0011
3	0011	0010
4	0100	0110
5	0101	0111
6	0110	0101
7	0111	0100
8	1000	1100
9	1001	1101
10	1010	1111
11	1011	1110
12	1100	1010
13	1101	1011
14	1110	1001
15	1111	1000

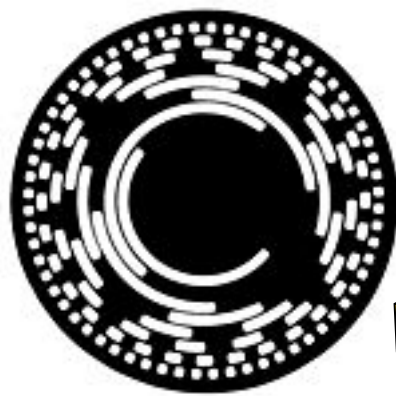

8-bit Gray-coded absolute encoder

adjacent codes differ by just one bit

Use of absolute encoders

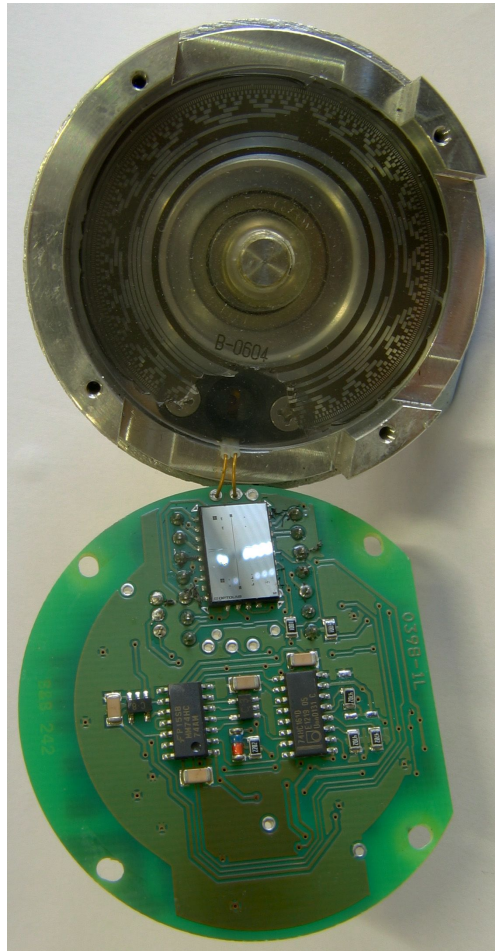

13-bit absolute encoder opened:
Gray-coded disk and electronics

- ready to measure at start (no “homing”)
- two modes for permanent operation
 - when switching off the drive, position parameters are saved on a flash memory (and brakes activated)
 - battery for the absolute encoder is always active, and measures position even when the drive is off
 - data memory > 20 years
- single-turn or multi-turn versions, e.g.
 - 13-bit single-turn has $2^{13} = 8192$ steps per revolution (resolution = 0.044°)
 - 29-bit multi-turn has 8192 steps/revolution + counts up to $2^{16} = 65536$ revolutions
- aluminum case with possible interface to field bus systems (e.g., CANopen or PROFIBUS)
- typical supply 5/28V DC @1.2 W



hollow shaft



round flange



Incremental encoders

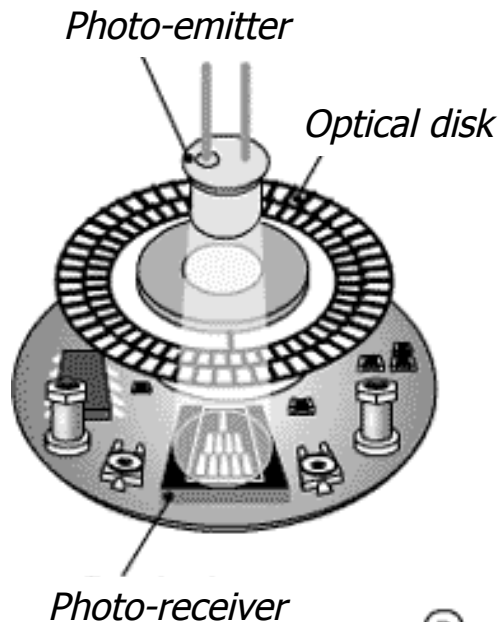

The three tracks on an optical disk (here $N_e = 6$)

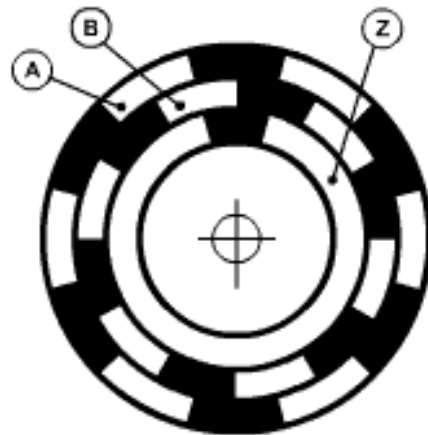

- optical rotating disk with three tracks, alternating transparent and opaque areas: measures **incremental** angular displacements by counting trains of N_e pulses ("counts") per turn ($N_e = 100 \div 5000$)
- the two A and B tracks (**channels**) are in quadrature (phase shift of 90° electrical), allowing to detect the direction of rotation
- a third track Z is used to define the "0" reference position, with a reset of the counter (**needs "homing"** at start)
- some encoders provide as output also the three phases needed for the switching circuit of brushless motors

Incremental encoders

- two (cheap) incremental encoders inside a mouse
- a OMRON incremental encoder with 2000 pulses/turn

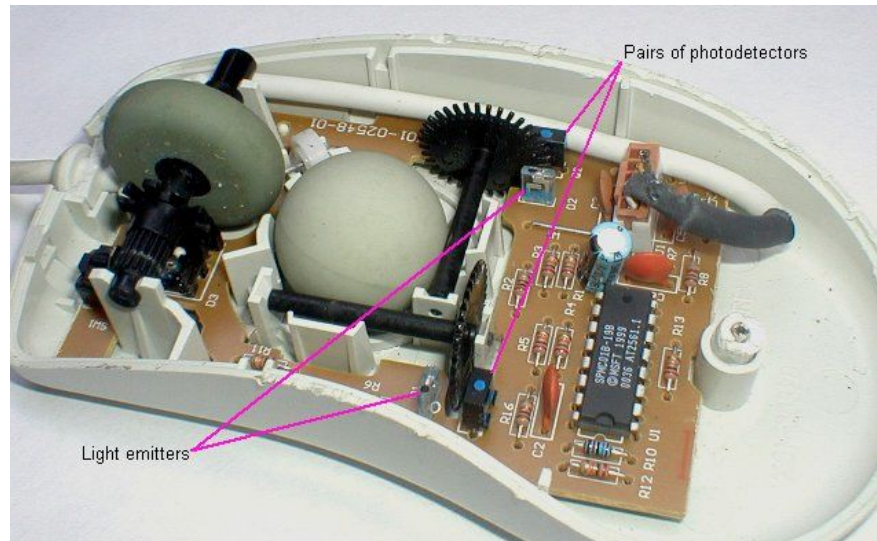

diameter \varnothing 40 mm
mass $m \approx 100$ g
inertia $J = 1 \cdot 10^{-6}$ kg m²



Signal processing

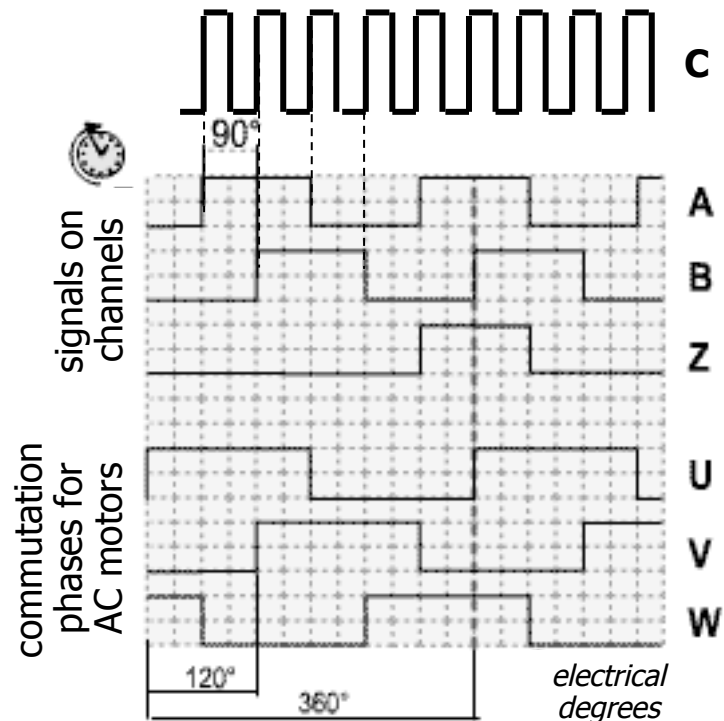

- "fractions of a cycle" of each pulse train are measured in "electrical degrees"
- $1^\circ \text{ electrical} = 1^\circ \text{ mechanical} / N_e$,
 $360^\circ \text{ mechanical} = 1 \text{ turn}$
- signals are fed in a digital **counter**, with a **D-type** flip-flop to sense direction + **reset**
- to **improve resolution (4x)**, the leading and trailing edges of signals A and B are used; it is the sequence of pulses C that clocks now the counter (**increments** or **decrements**)

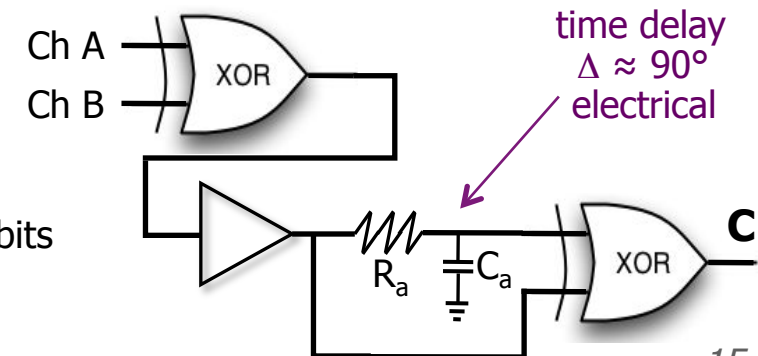
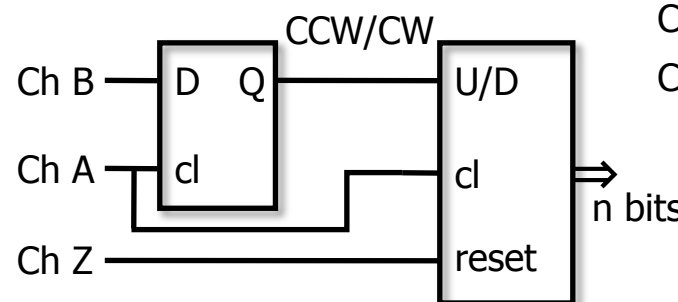
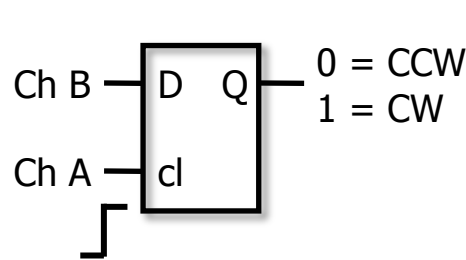

Quadrature detection in incremental encoders

a more complete implementation

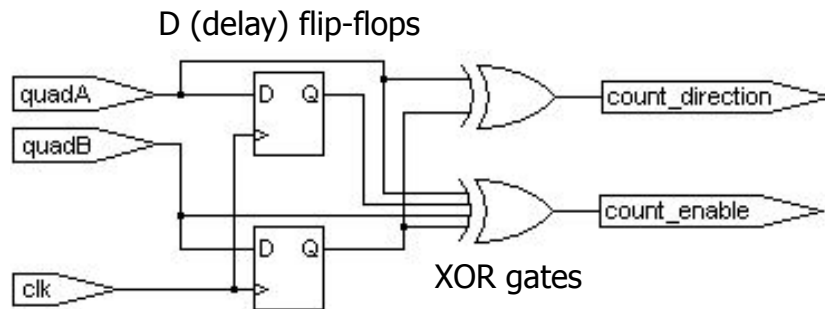

NOTE: since in practice A and B signals may **not** be synchronous to the clock signal, two extra D flip-flops per input should be used to avoid meta-stable states in the counters

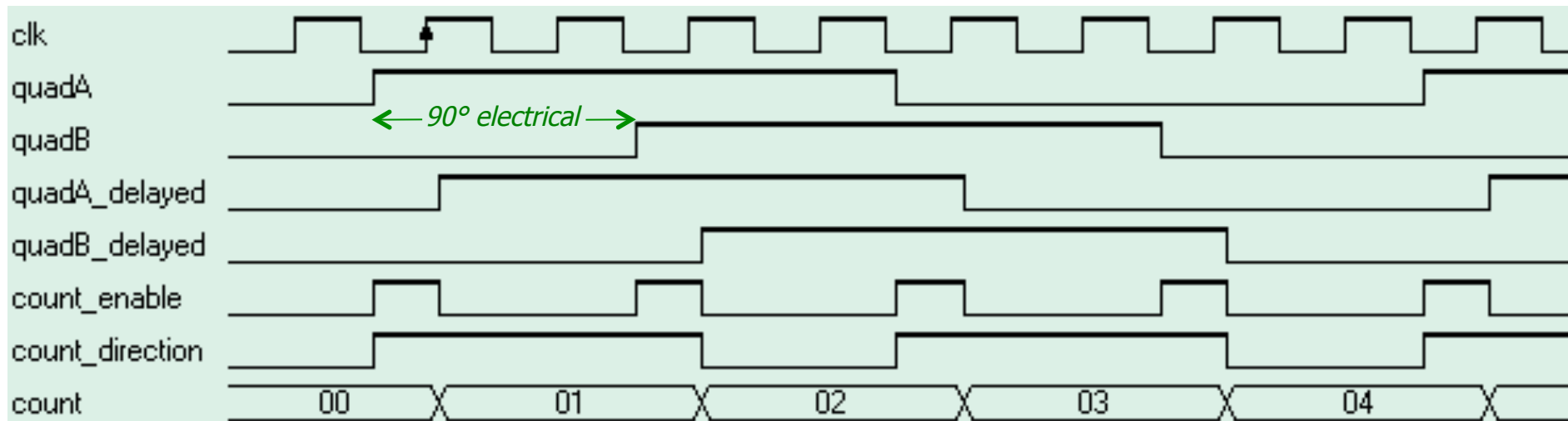

- it is assumed that an oversampling clock "clk" (e.g., as provided by a FPGA) is available, which is faster than the two quadrature signals A and B
- the digital count output will have a **resolution** multiplied by 4



Count multiplication

example of quadrature detection

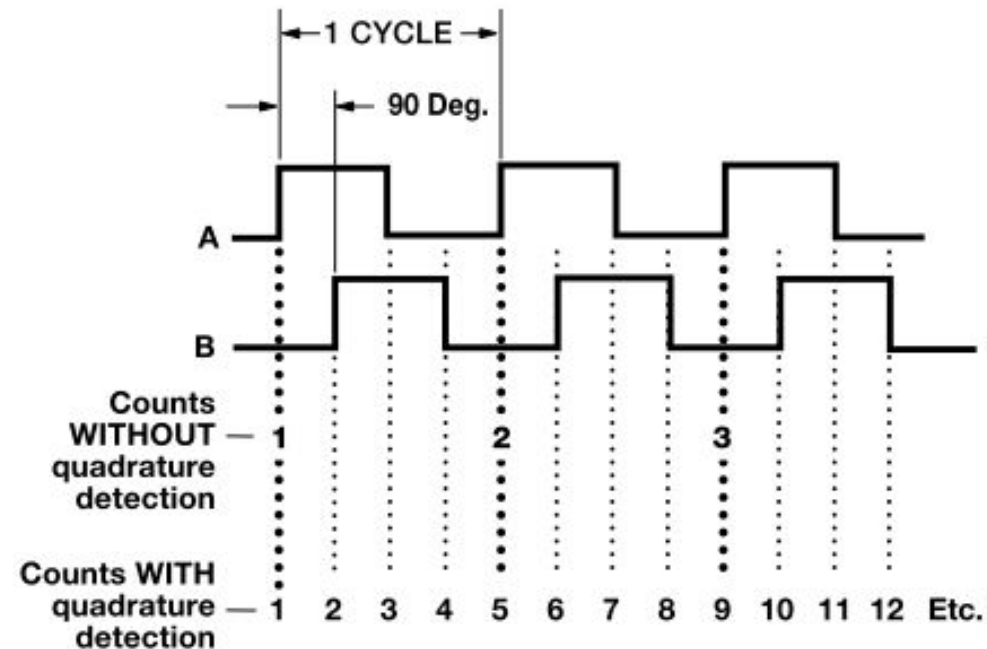

- an incremental encoder with $N_e = 2000$ (electrical) cycles provides a count of $N = 8000$ pulses/turn after electronic multiplication
- its final **resolution** is (mechanical) $360^\circ/8000 = .045^\circ (= 0^\circ 2' 42'')$
- needs a 13-bit counter to cover a full turn without reset ($2^{13} = 8192$)



Accuracy in incremental encoders

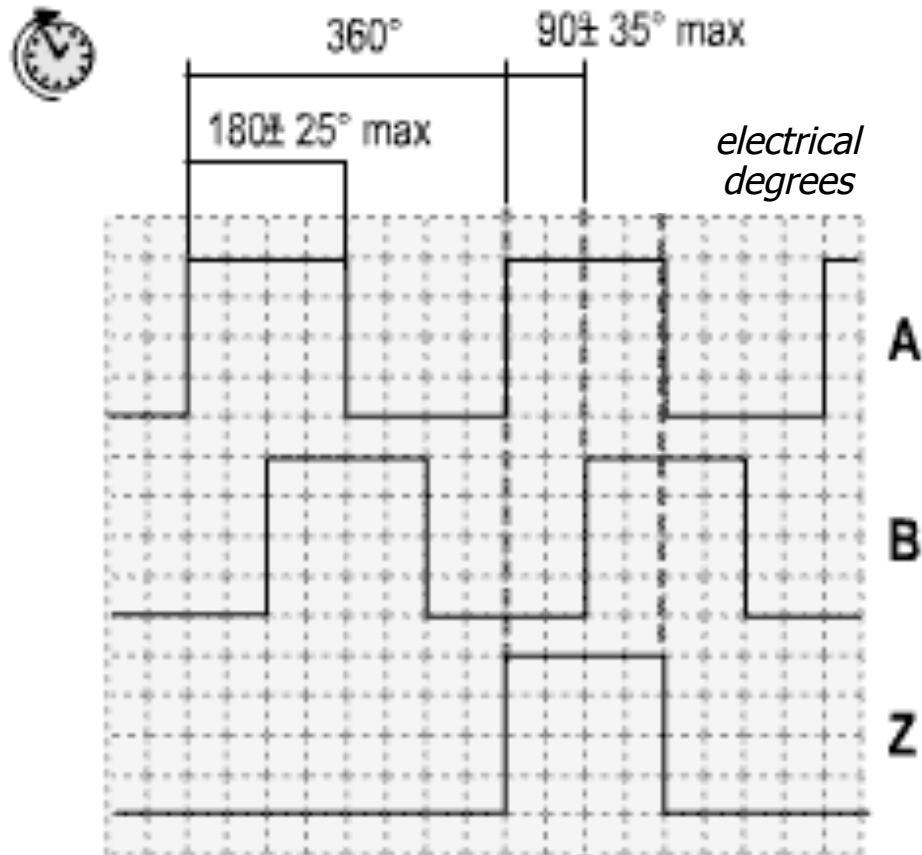

...apart from quantization errors

- **division error**: maximum displacement between two consecutive leading/trailing edges, typically within max $\pm 25^\circ$ electrical
- the **phase shift** of the two channels, nominally equal to 90° electrical, is typically within max $\pm 35^\circ$ electrical (**quadrature error**)



Indirect measure of velocity

- numerical differentiation of digital measures of position
 - to be realized on line with Backward Differentiation Formulas (BDFs)
 - 1-step BDF (Euler method): $\dot{q}_k = \dot{q}(kT) = \frac{1}{T}(q_k - q_{k-1}) \Leftrightarrow \dot{q}_k = \Delta q_k / T \Leftarrow$ directly from incremental encoder
 - 4-step BDF: $\dot{q}_k = \frac{1}{T} \left(\frac{25}{12} q_k - 4q_{k-1} + 3q_{k-2} - \frac{4}{3} q_{k-3} + \frac{1}{4} q_{k-4} \right)$
- convolution filtering is needed because of noise and position quantization
 - use of non-causal filters (e.g., Savitzky-Golay) helps, but introduces delays
- Kalman filter for on line state estimation (optimal, assuming Gaussian noise)

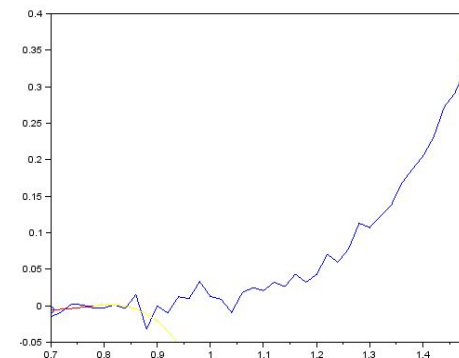
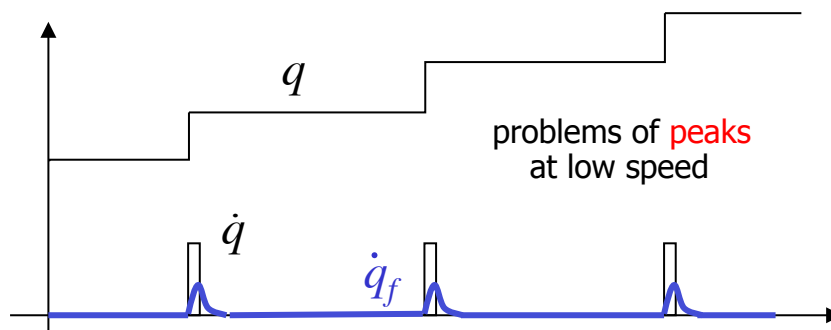

animation of Savitzky-Golay filter with cubic polynomials



Kinematic Kalman Filter for velocity estimation

motion and sensing
discrete-time
model for estimation

$$\xi(k) = \begin{pmatrix} 1 & T \\ 0 & 1 \end{pmatrix} \xi(k-1) + \mu$$

$$z(k) = (1 \ 0) \xi(k) + \nu$$

noisy **position measure**
(encoder output)

zero mean
Gaussian noises
with (co)variances
 Q (a matrix) and R

T = sampling time

$$\xi(k) = (x(k) \ \dot{x}(k))^T$$

actual
state

**unmeasured
velocity**

design a (linear) **Kalman filter** providing an **estimate** $\hat{\xi}(k)$ of the model state

$$\hat{\xi}(k) = \underbrace{\begin{pmatrix} 1 & T \\ 0 & 1 \end{pmatrix} \hat{\xi}(k-1)}_{\text{(a priori) prediction}} + \underbrace{K_k \left(z(k) - (1 \ 0) \begin{pmatrix} 1 & T \\ 0 & 1 \end{pmatrix} \hat{\xi}(k-1) \right)}_{\text{correction (based on the measured output)}} \quad \text{using the optimal Kalman gain } K_k$$

position measure and its filtered version

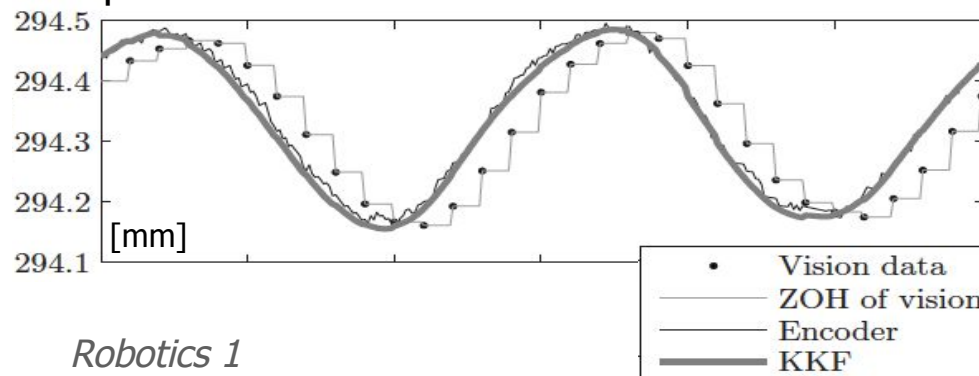

numerical velocity and its filtered estimate

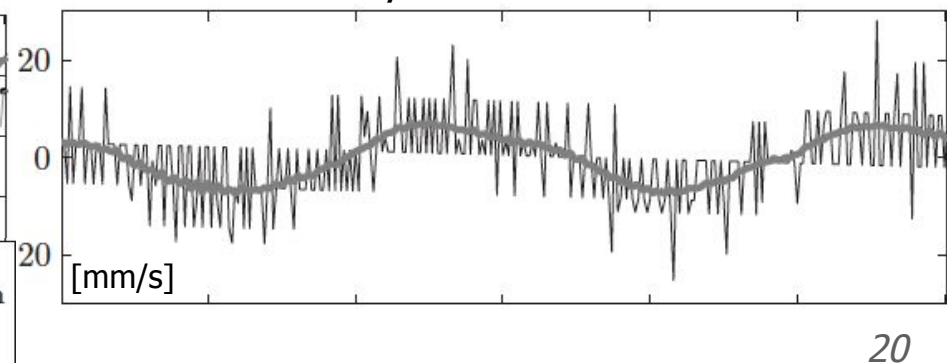



Velocity sensor: Tachometer

always mounted on the (electrical) motor axis

principle of operation (single coil)

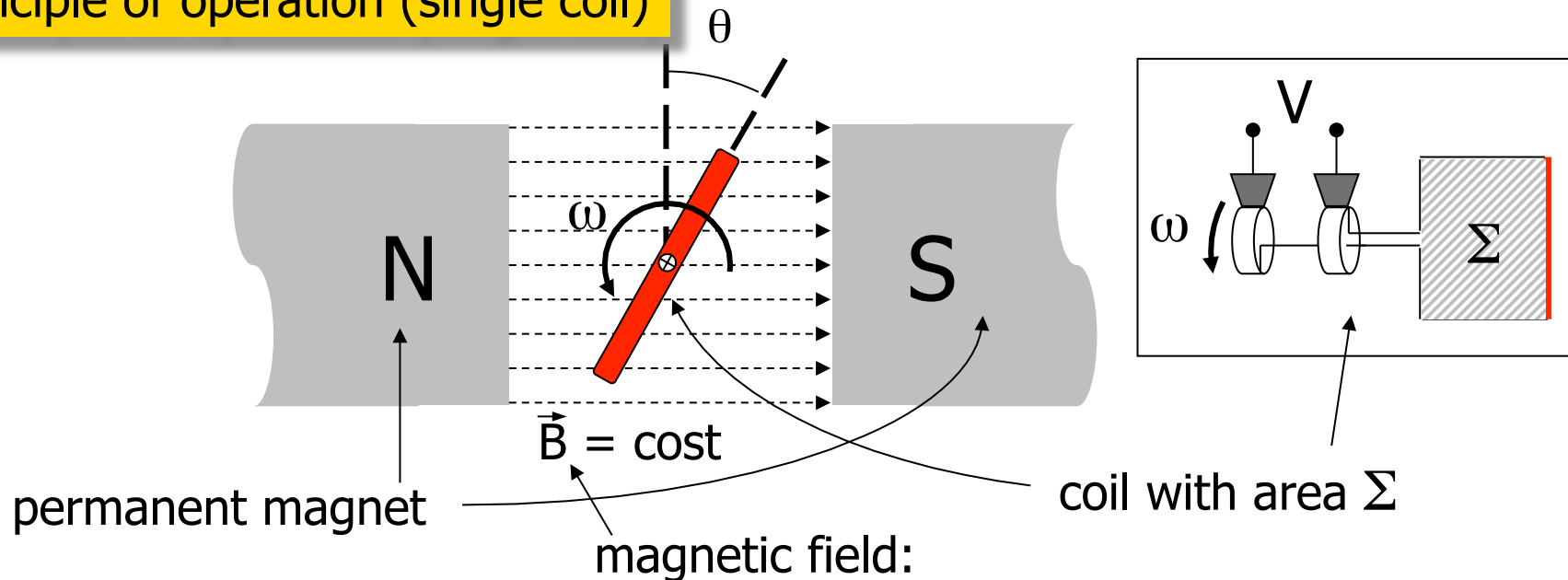

magnetic field:
flux through the coil is $\Phi(\vec{B}) = |\vec{B}|\Sigma \cos \theta = |\vec{B}|\Sigma \cos \omega t$

$$V = - d\Phi/dt = |\vec{B}|\Sigma \omega \sin \omega t$$

amplitude $V \propto \omega$

⇒ to reduce ripples, use m coils rotated regularly by $180^\circ/m$



DC tachometer

an example



- Servo-Tek Tach Generator (B series)
- bi-directional
- output voltage 11÷24 V @1000 RPM
- low ripple: < 3% peak-to-peak of DC value (with 72 KHz filter)
- weight = 113 g, diameter = 2.9 cm
- linearity error < 0.1% (at any speed)
- stability 0.1% (w.r.t. temperature)

B-Series Specifications

Model Number	Mounting	Weight (approx)	Inertia (approx) oz-in.-sec ²	V/1,000 RPM	RPM (max)	Driving Torque (max)	Arm R (ohms dynamic)	Arm Ind (h)
SA-740B-1*	Face	4.0 oz	2.27×10^{-4}	20.8 V	8000	0.25 oz-in.	1000	0.56
SB-740B-1*	Flange	4.0 oz	2.27×10^{-4}	20.8 V	8000	0.25 oz-in.	1000	0.56
SA-757B-1*	Face	4.0 oz	2.27×10^{-4}	20.8 V	8000	0.25 oz-in.	1000	0.56
SB-757B-1*	Flange	4.0 oz	2.27×10^{-4}	20.8 V	8000	0.25 oz-in.	1000	0.56

↑
1.75 mNm (as a load)



Accelerometers

- measure of linear acceleration based on **inertial forces** (no “touch”)
 - units: $[m/s^2]$ or gravitational acceleration $[g]$ (non-SI unit: $1g \approx 9.81 m/s^2$)
- different principles for converting mechanical motion in an electrical signal
 - **piezoelectric**: piezoceramics (PZT) or crystals (quartz), better linearity & stability, wide dynamic range up to high frequencies, no moving parts, no power needed
 - **piezoresistive**: for high-shocks, measures also static acceleration (g), needs supply
 - **capacitive**: silicon micro-machined sensing element, superior in static to low frequency range, can be operated in servo mode, cheap but limited resolution
 - modern solution: small **MEMS** (Micro Electro-Mechanical Systems)
- multiple applications: from vibration analysis to long range navigation

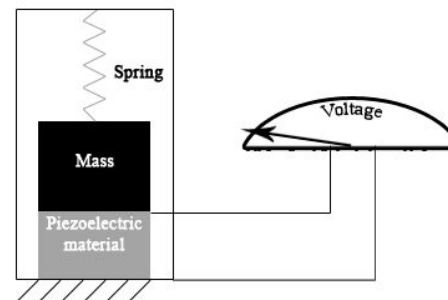
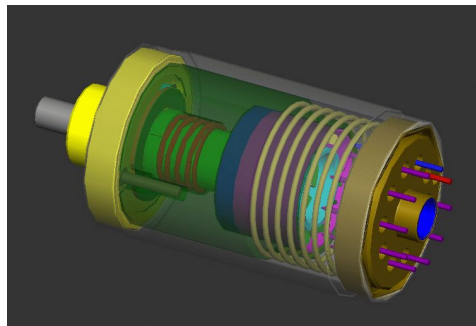

animation of measurement principle in a piezoelectric accelerometer



Operation principle seismic accelerometer

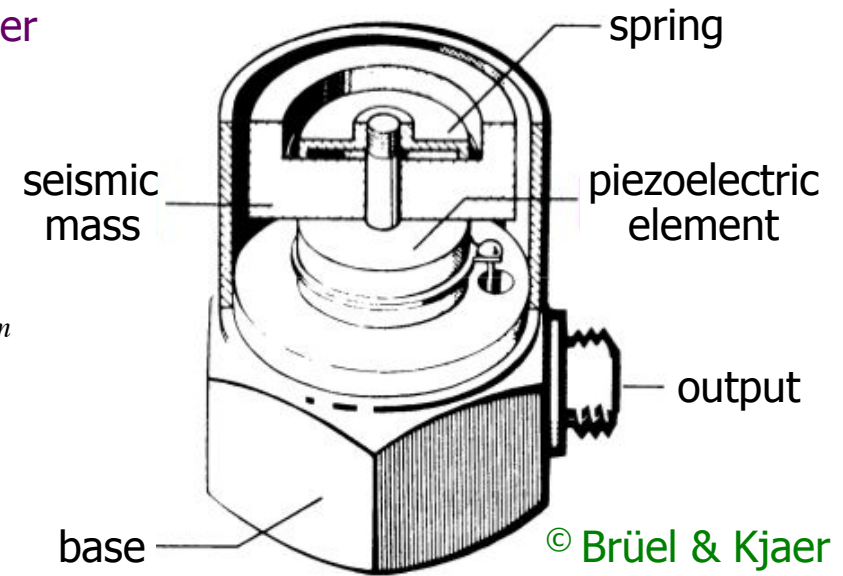
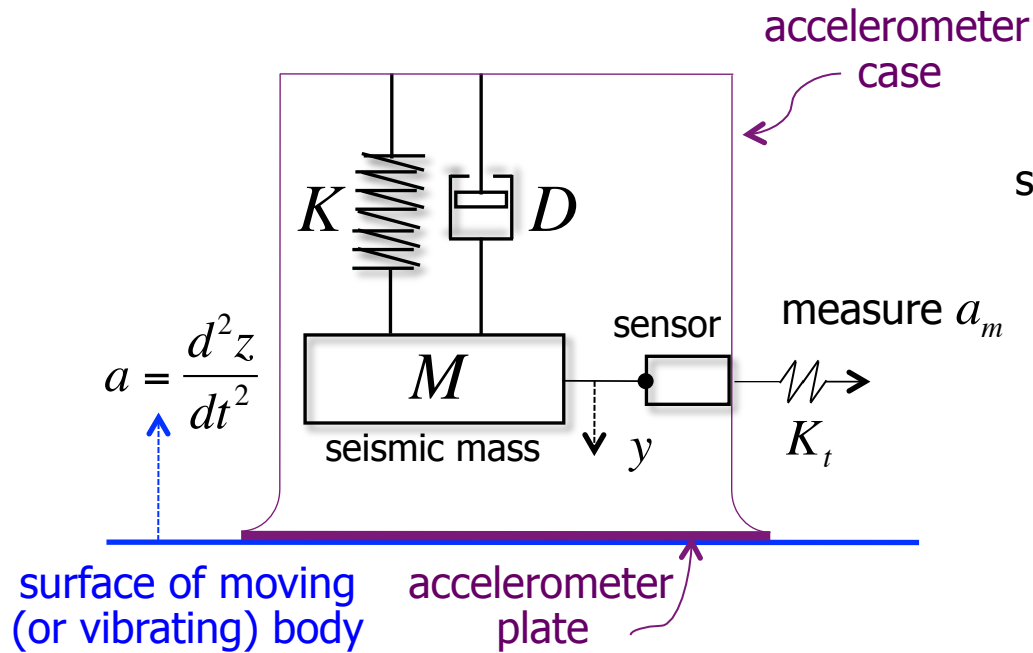

$$M a = M \ddot{y} + D \dot{y} + K y$$

$$a_m = K_t y$$

by Laplace

transform

$$\begin{aligned} \frac{A_m(s)}{A(s)} &= K_t \frac{M}{Ms^2 + Ds + K} \\ &= \frac{K_t}{s^2 + (D/M)s + (K/M)} \end{aligned}$$



Frequency characteristics of a piezoelectric accelerometer

$$F(s) = \frac{A_m(s)}{A(s)} = \frac{K_t}{s^2 + (D/M)s + (K/M)}$$

$$\omega_r = \sqrt{\frac{K}{M}}$$

resonance
frequency

$$\xi = \frac{D}{2} \sqrt{\frac{1}{KM}}$$

damping
factor

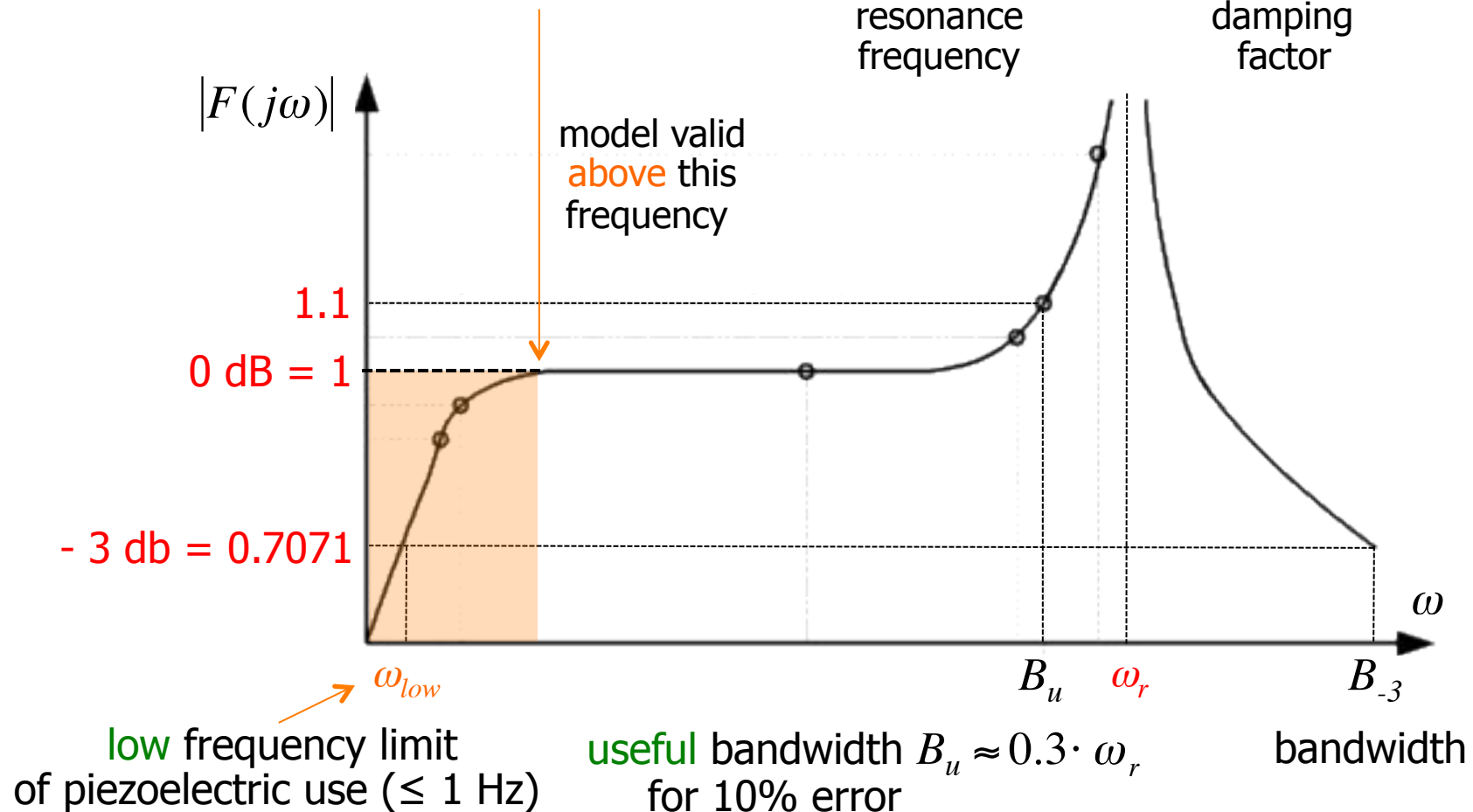



MEMS accelerometers

- very simple MEMS (a **cantilever** beam with a **test mass**, with damping from the residual gas sealed in the device), single- or **tri-axial**, very small and light
- **cross-couplings** among acceleration sensing directions should be limited $\leq 3\%$

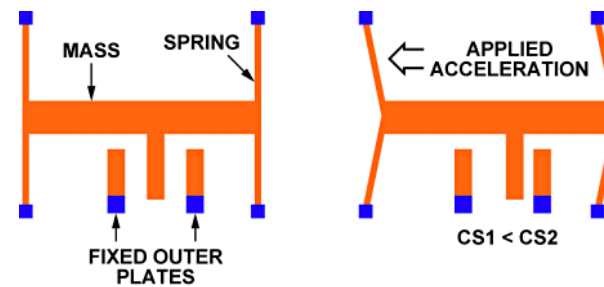
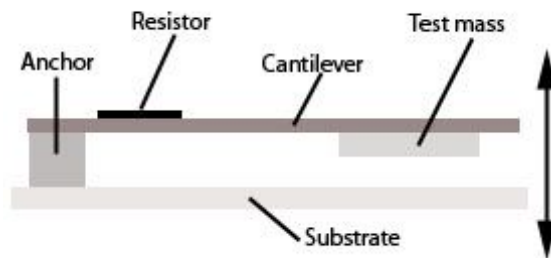

ADXL335 3-axis, small, low power, $\pm 3g$, with signal conditioned voltage outputs

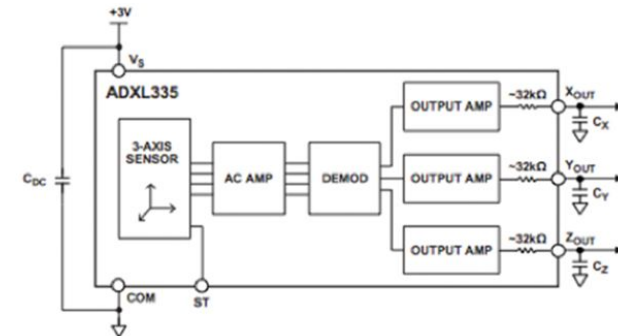
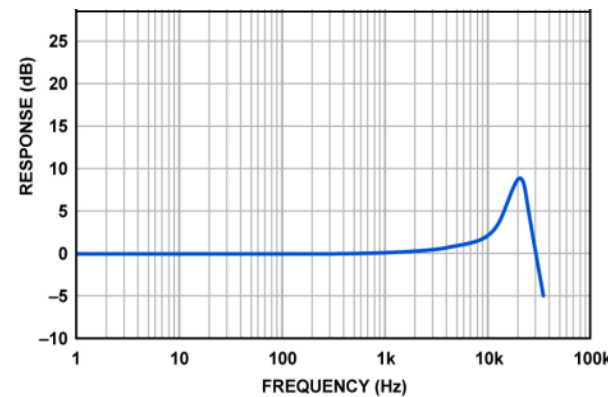
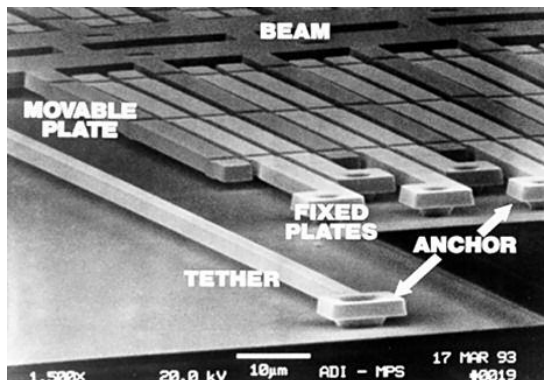

Mounting accelerometers on robots

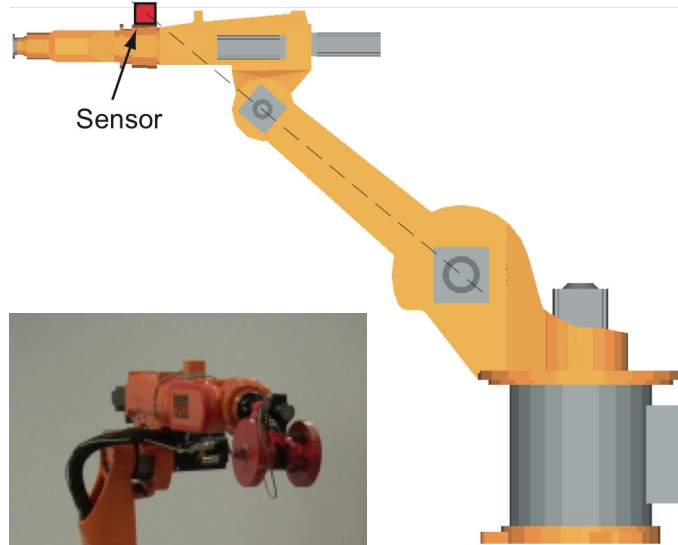

3-axial MEMS accelerometer on the forearm of a **KUKA KR15/2** [DLR/Sapienza, 2007]

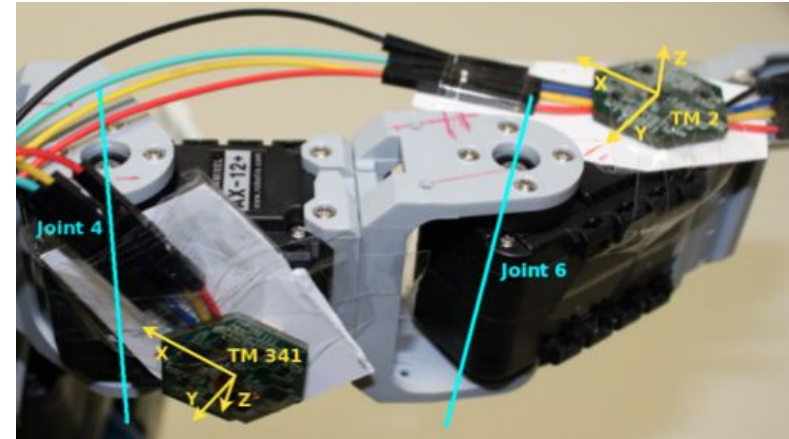

Bosch BMA 150 3-axial accelerometers integrated in two larger Tactile Modules on the links of a **Bioid humanoid** left arm [TUM, 2011]

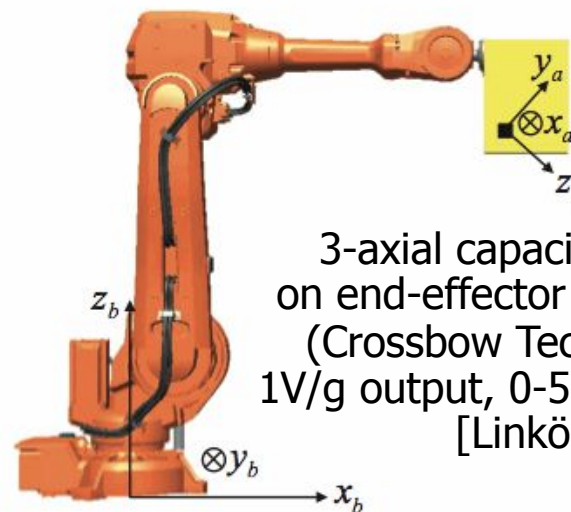

3-axial capacitive accelerometer on end-effector tool of an **ABB robot** (Crossbow Technology: 2g range, 1V/g output, 0-50 Hz, $\pm 2^\circ$ align error) [Linköping, 2012]