



Robotics 1

Robot components: Actuators

Prof. Alessandro De Luca

DIPARTIMENTO DI INGEGNERIA INFORMATICA
AUTOMATICA E GESTIONALE ANTONIO RUBERTI



SAPIENZA
UNIVERSITÀ DI ROMA



Robot as a system

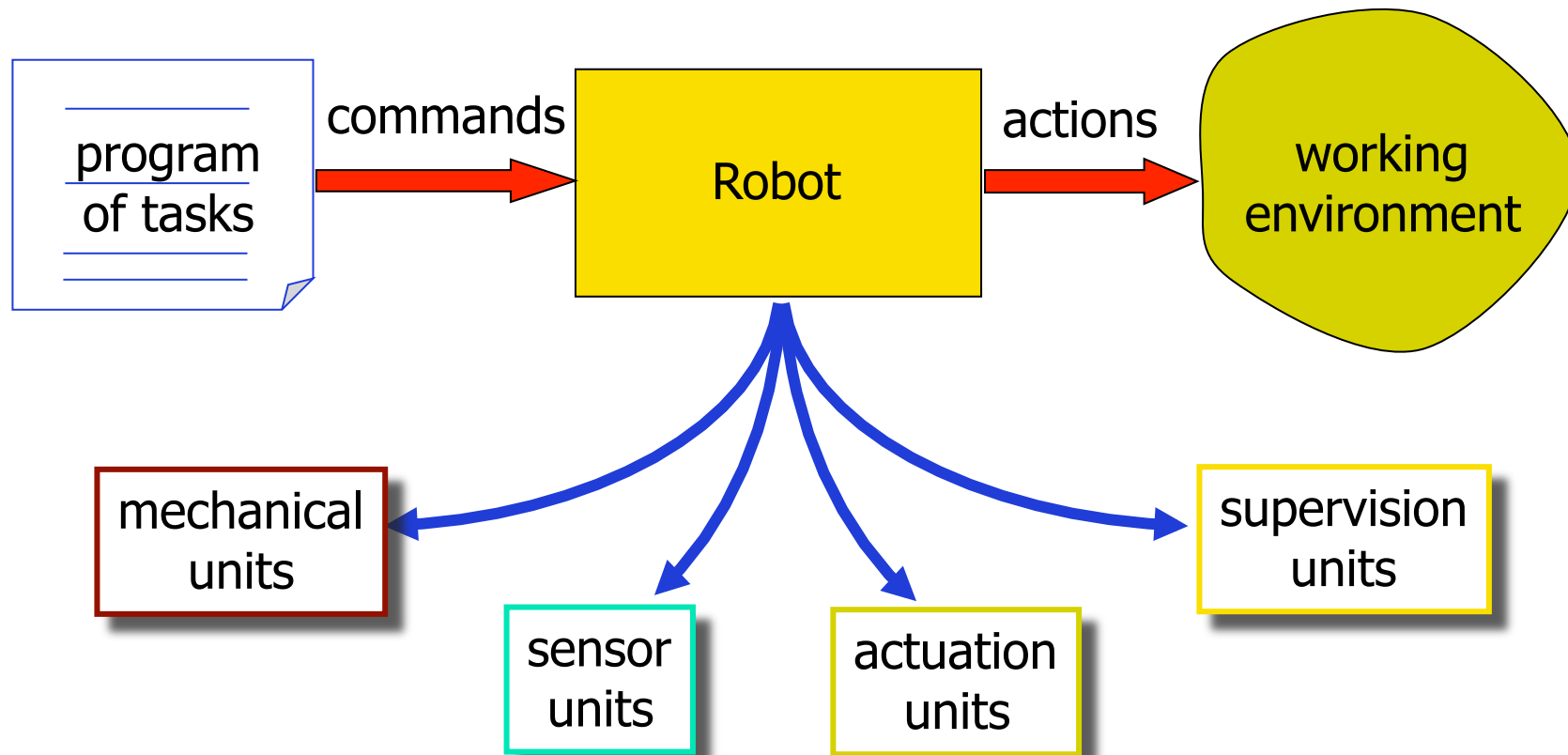



Functional units of a robot

- mechanical units (robot arms)
 - rigid links connected through *rotational* or *prismatic* joints (each 1 dof)
 - mechanical subdivisions:
 - *supporting structure* (mobility), *wrist* (dexterity), *end-effector* (task execution, e.g., manipulation)
- sensor units
 - proprioceptive (internal robot state: position and velocity of the joints)
 - exteroceptive (external world: force and proximity, vision, ...)
- actuation units
 - motors (*electrical, hydraulic, pneumatic*)
 - motion control algorithms
- supervision units
 - task planning and control
 - artificial intelligence and reasoning



Actuation systems

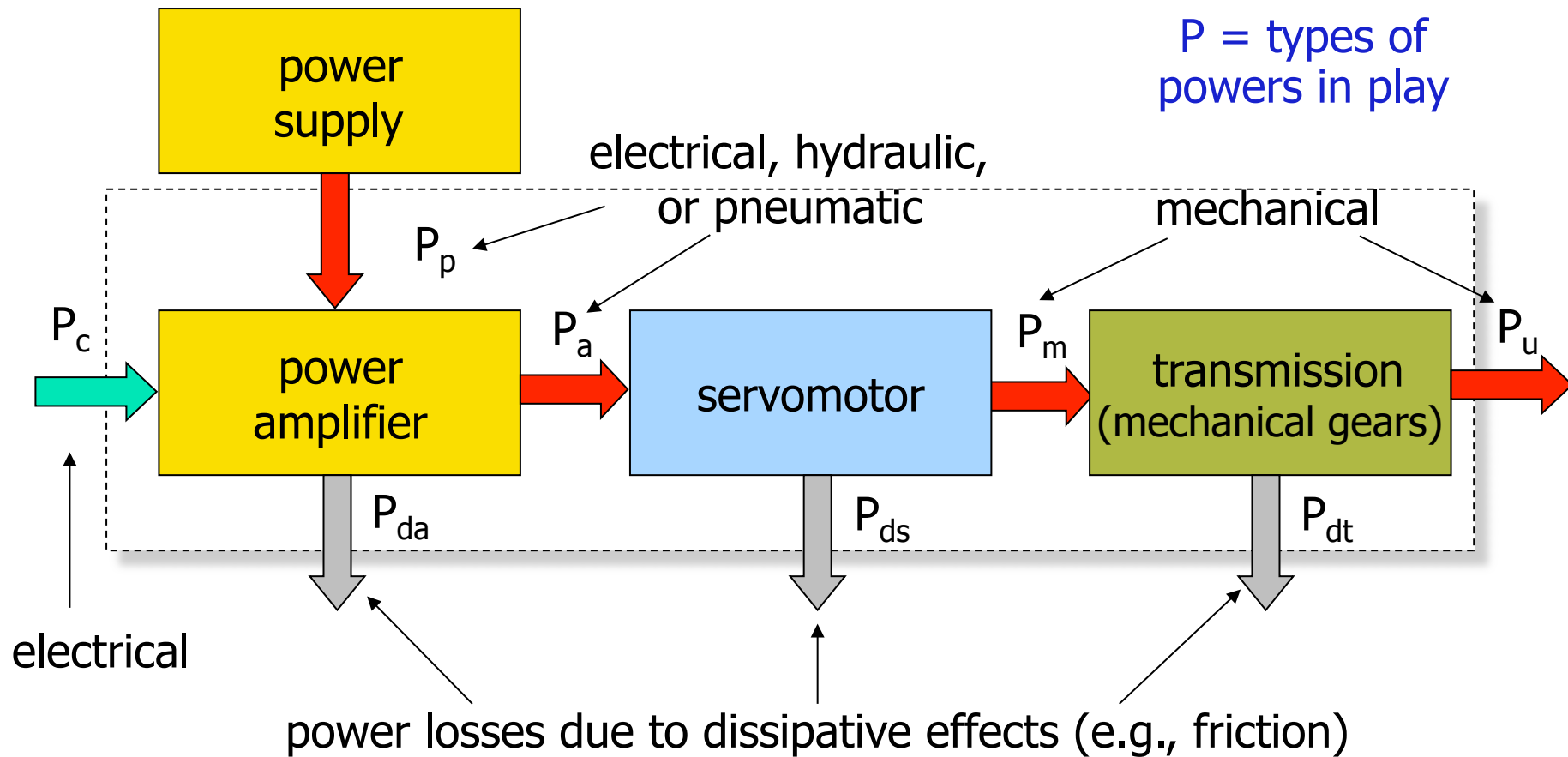

power = force · speed = torque · angular speed [Nm/s, W]

efficiency = power out / power in [%]



Motion transmission gears

- optimize the transfer of mechanical torque from actuating motors to driven links
- quantitative transformation (from **low torque/high velocity** to **high torque/low velocity**)
- qualitative transformation (e.g., from **rotational** motion of an electrical motor to a **linear** motion of a link along the axis of a prismatic joint)
- allow improvement of static and dynamic performance by reducing the weight of the actual robot structure in motion (locating the motors remotely, closer to the robot base)



Elementary transmission gears

- racks and pinion
 - one rack moving (or both)
- epi-cycloidal gear train
 - or hypo-cycloidal (small gear inside)
- planetary gear set
 - one of three components is locked: sun gear, planet carrier, ring gear

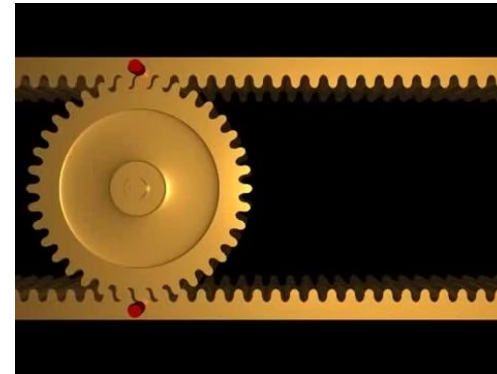

video



video

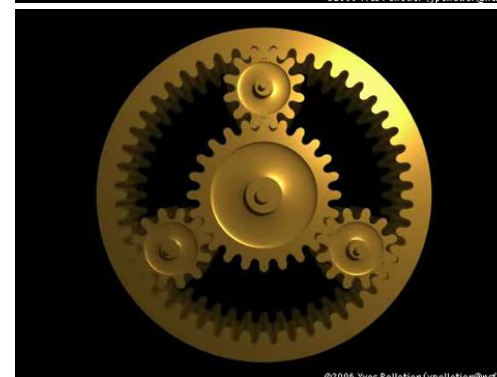

video



Transmissions in robotics

- **spur gears:** modify direction and/or translate axis of (rotational or translational) motor displacement
 - problems: **deformations**, **backlash**
- **lead screws, worm gearing:** convert rotational into translational motion (prismatic joints)
 - problems: **friction**, **elasticity**, **backlash**
- **toothed belts and chains:** dislocate the motor w.r.t. the joint axis
 - problems: **compliance** (belts) or **vibrations** induced by larger mass at high speed (chains)
- **harmonic drives:** compact, in-line, power efficient, with high reduction ratio (up to 150-200:1)
 - problems: **elasticity**
- **transmission shafts:** inside the links...



Harmonic drives

Wave Generator (C) of slightly elliptic external form
Circular Spline (A)

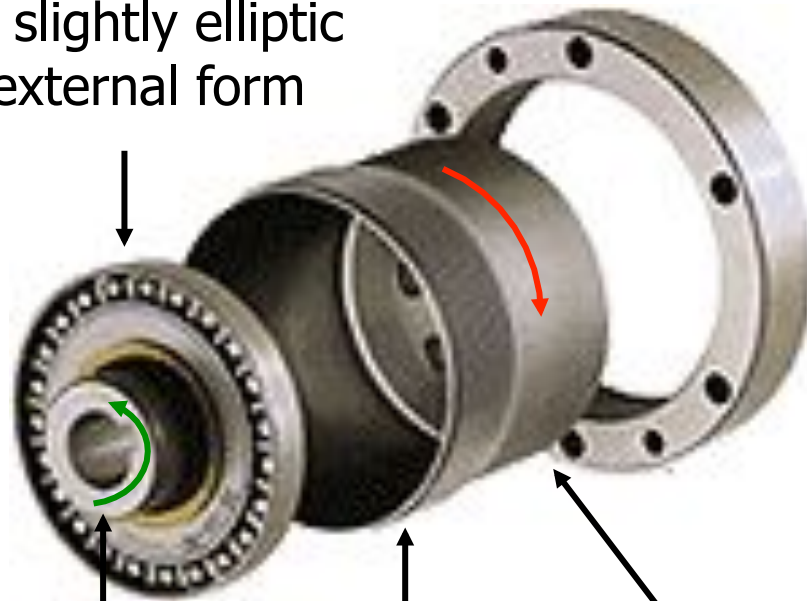

FlexSpline (B)
(two contact points)

input from motor

output to load



$$\begin{aligned} \text{inner \#teeth CS} &= \text{outer \#teeth FS} + 2 \\ \text{reduction ratio} \\ n &= \frac{\text{\#teeth FS}}{(\text{\#teeth CS} - \text{\#teeth FS})} \\ &= \frac{\text{\#teeth FS}}{2} \end{aligned}$$

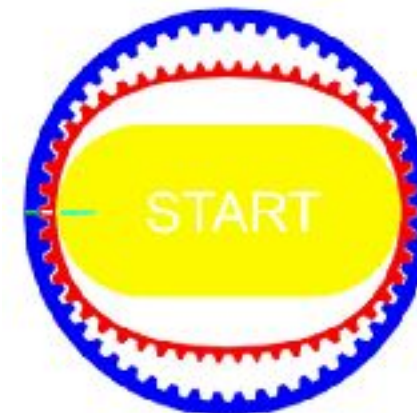



Operation of an harmonic drive



commercial [video](#) by Harmonic Drives AG



Optimal choice of reduction ratio

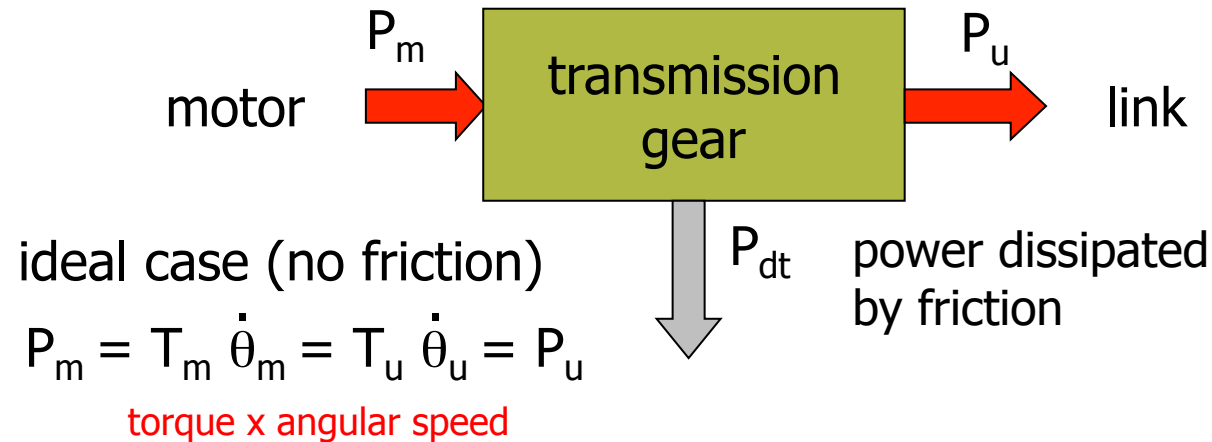

$n = \text{reduction ratio } (\gg 1) \quad \dot{\theta}_m = n \dot{\theta}_u \quad \Rightarrow \quad T_u = n T_m$

to have $\ddot{\theta}_u = a$ (thus $\ddot{\theta}_m = n a$), the motor should provide a torque

$$T_m = J_m \ddot{\theta}_m + 1/n (J_u \ddot{\theta}_u) = (J_m n + J_u/n) a$$

inertia x angular acceleration

for minimizing T_m , we set: $\frac{\partial T_m}{\partial n} = (J_m - J_u/n^2) a = 0$

$\Rightarrow n = (J_u / J_m)^{1/2}$ "matching" condition between inertias

Inside views on joint axes 4, 5 & 6 of an industrial KUKA robot



- looking inside the forearm to see the transmissions of the spherical wrist
- motor rotation seen from the encoder side (small couplings exist)



Robotics 1

video



video

Desired characteristics for robot servomotors



- low inertia
- high power-to-weight ratio
- high acceleration capabilities
 - variable motion regime, with several stops and inversions
- large range of operational velocities
 - 1 to 1000 turns/min
- high accuracy in positioning
 - at least 1/1000 of a turn
- low torque ripple
 - continuous rotation at low speed
- power: 10W to 10 kW



Servomotors

- **pneumatic:** pneumatic energy (compressor) → pistons or chambers → mechanical energy
 - difficult to control accurately (change of fluid compressibility) → no trajectory control
 - used for opening/closing grippers
 - ... or as artificial muscles (McKibben actuators)
- **hydraulic:** hydraulic energy (accumulation tank) → pumps/valves → mechanical energy
 - **advantages:** no static overheating, self-lubricated, inherently safe (no sparks), excellent power-to-weight ratio, large torques at low velocity (w/o reduction)
 - **disadvantages:** needs hydraulic supply, large size, linear motion only, low power conversion efficiency, high cost, increased maintenance (oil leaking)





Electrical servomotors

■ advantages

- power supply available everywhere
- low cost
- large variety of products
- high power conversion efficiency
- easy maintenance
- no pollution in working environment

■ disadvantages

- overheating in static conditions (in the presence of gravity)
 - use of emergency brakes
- need special protection in flammable environments



Electrical servomotors for robots

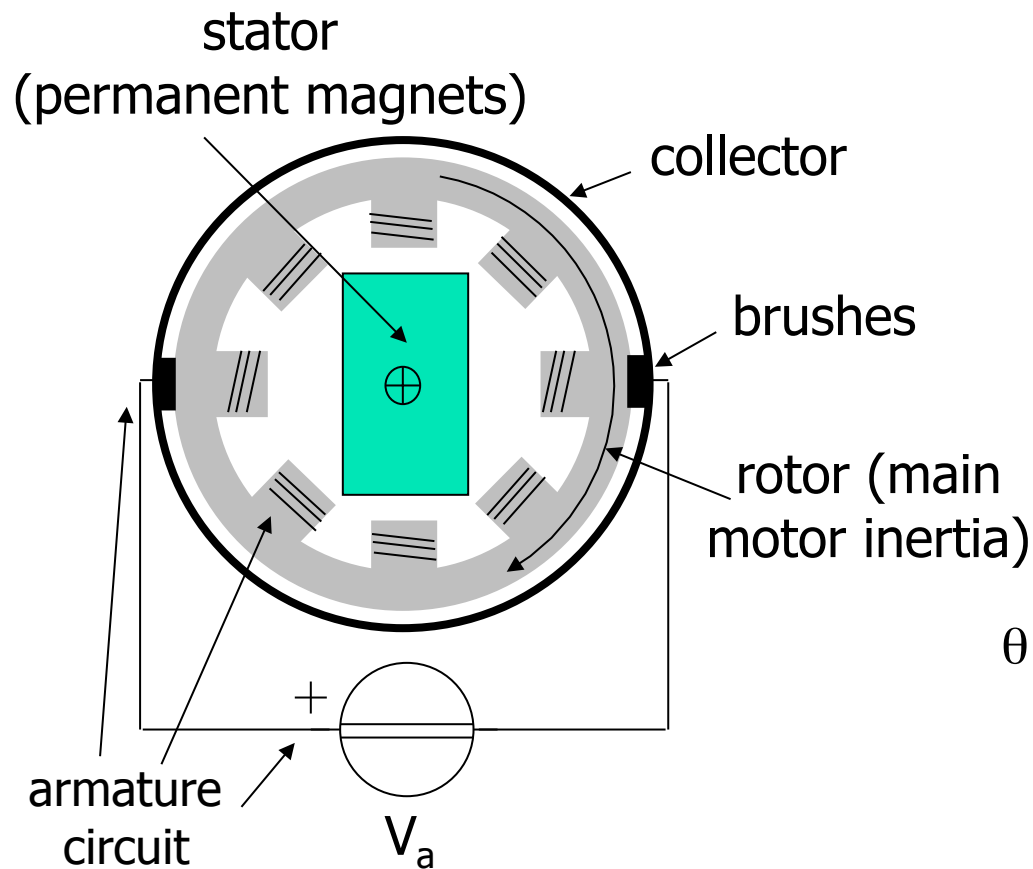

direct current (DC) motor

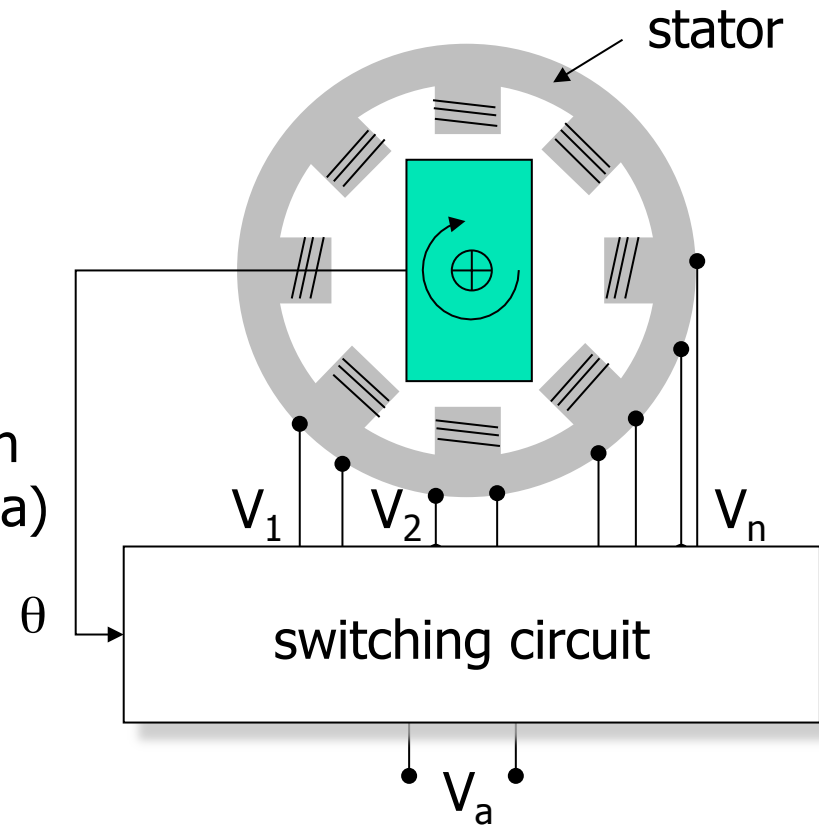

with electronic switches (brushless)



Advantages of brushless motors

- reduced losses, both electrical (due to tension drops at the collector-brushes contacts) and mechanical (friction)
- reduced maintenance (no substitution of brushes)
- easier heat dissipation
- more compact rotor (less inertia and smaller dimensions)

... but indeed a higher cost!



Principle of operation of a DC motor

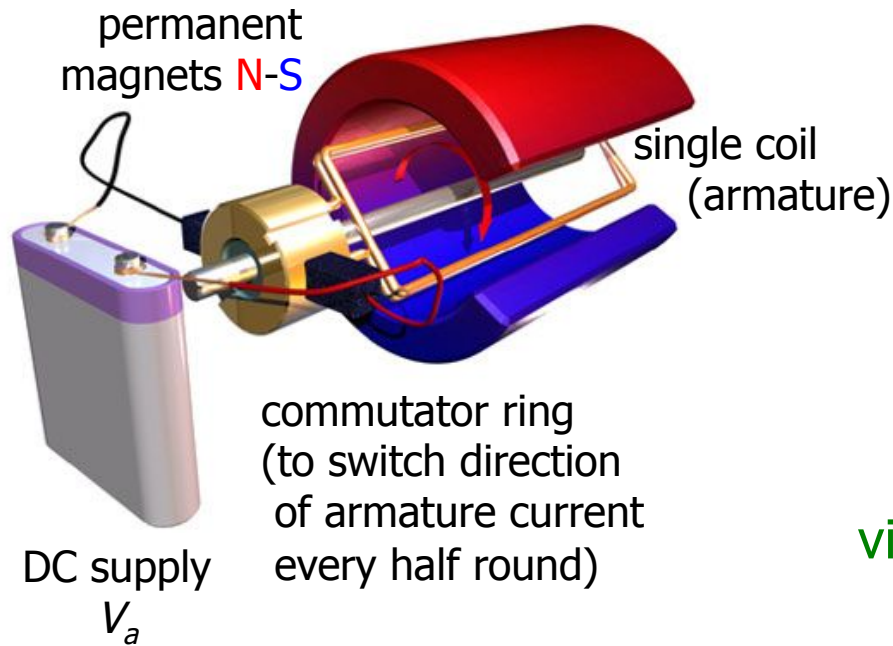

video

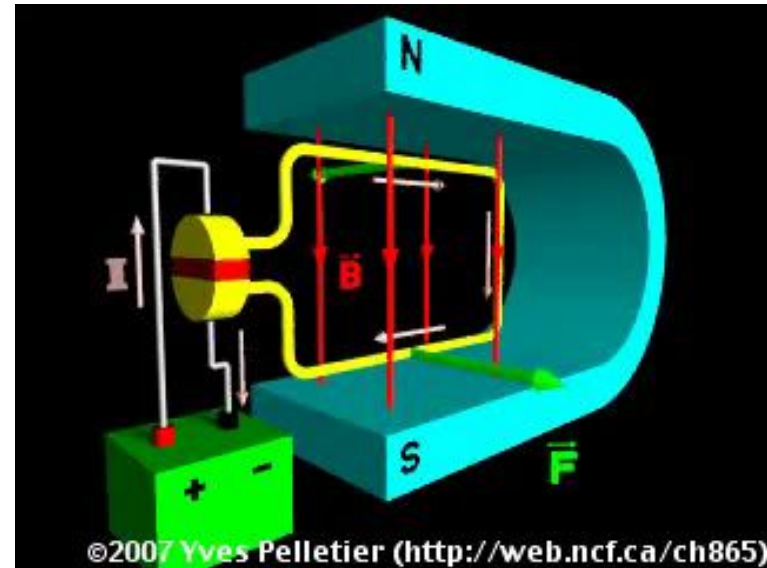

$$\vec{F} = L (\vec{i} \times \vec{B}) \quad T = r \cdot \|\vec{F}\|$$

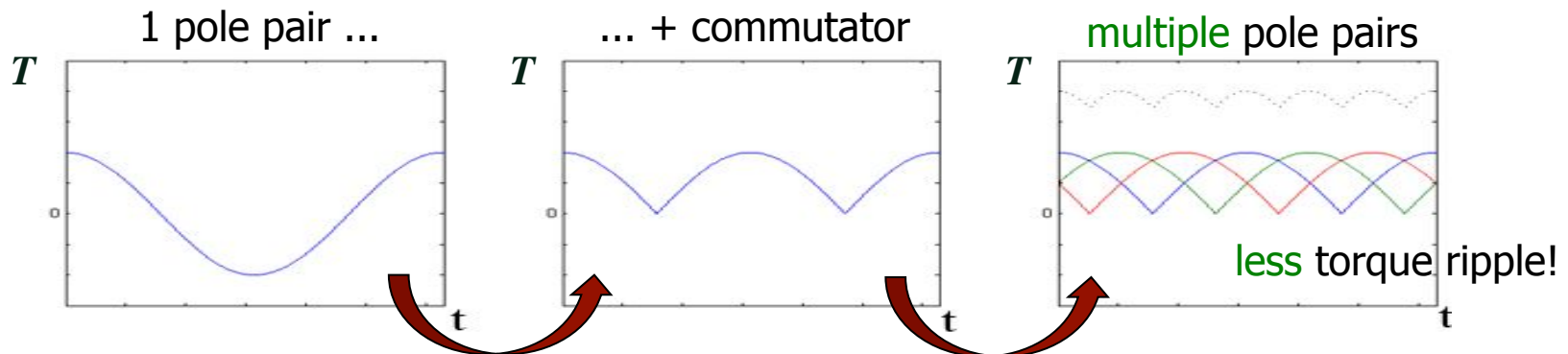



Characteristic curves of a DC motor

at steady-state,
for constant
applied currents V_a

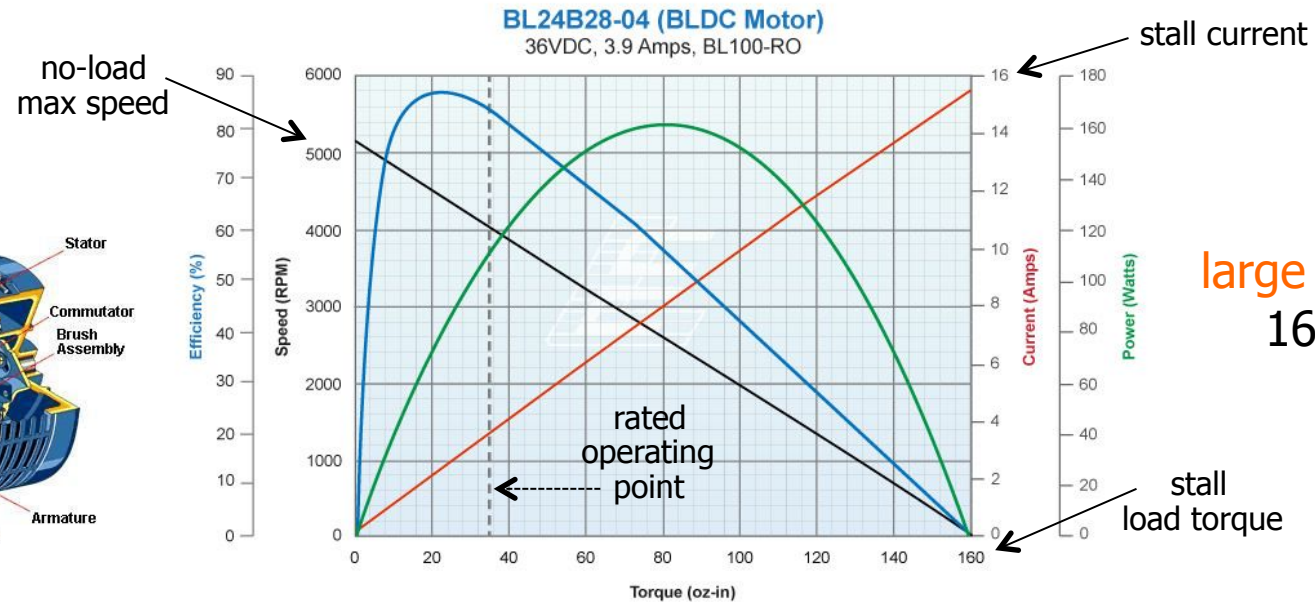
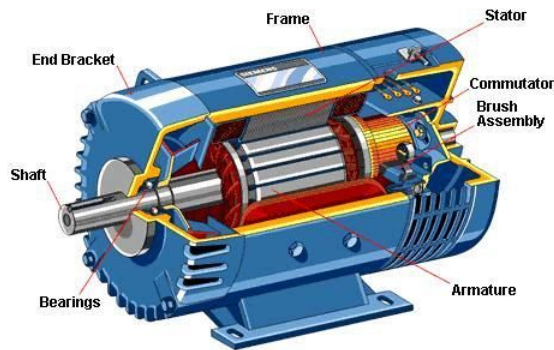

large motor
160W

conversion SI \leftrightarrow US
unit systems (!!)
1 Nm = 141.61 oz-in
100 oz-in = 0.70 Nm

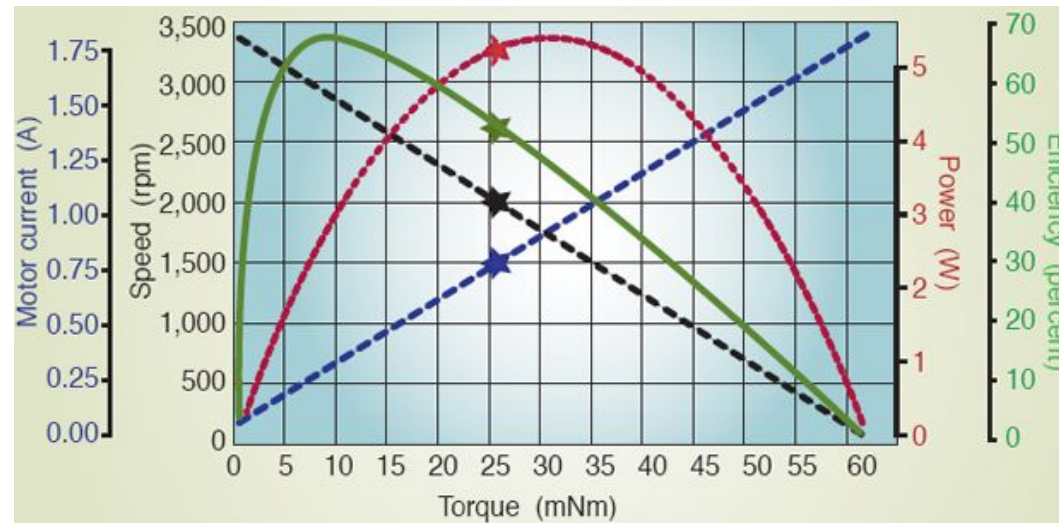

small motor
5.5W



DC electrical motor

mathematical model for command and control

electrical balance

Laplace domain
(transfer functions)

mechanical balance

$$V_a = (R_a + sL_a) I_a + V_{emf}$$

$$T_m = (sI_m + F_m) \Omega + T_{load}$$

$$V_{emf} = k_v \Omega \text{ (back emf)}$$

$$T_m = k_t I_a$$

$$k_v = k_t \text{ (energy balance, in SI units!)}$$

current loop

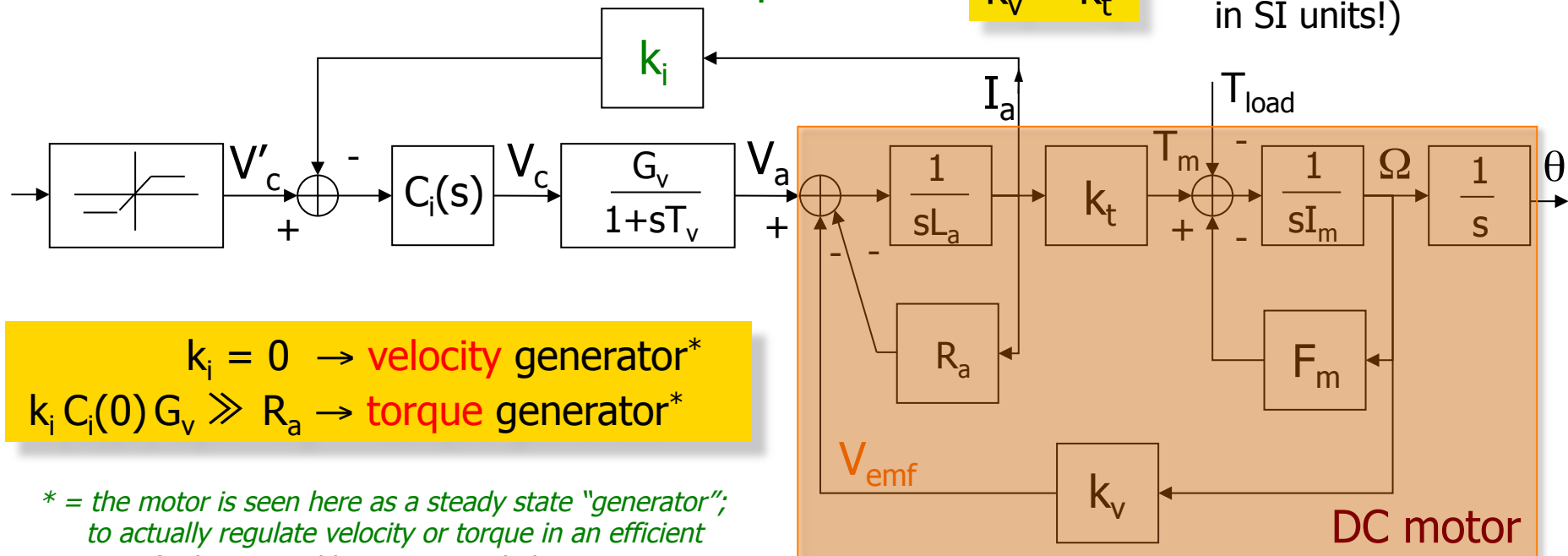

$k_i = 0 \rightarrow$ velocity generator*
 $k_i C_i(0) G_v \gg R_a \rightarrow$ torque generator*

* = the motor is seen here as a steady state "generator";
 to actually regulate velocity or torque in an efficient way, further control loops are needed!



Data sheet electrical motors

- DC drives



Model of actuator		RHS-14		RHS-17		RHS-20/RFS-20				RHS-25/RFS-25				RHS-32/RFS-32			
		6003	3003	6006	3006	6007	3007	6012	3012	6012	3012	6018	3018	6018	3018	6030	3030
Rated Torque	Inlb	48	69	87	177	106	212	177	266	177	354	266	531	266	531	443	885
	Nm	5.4	7.8	9.8	20	12	24	20	30	20	40	30	60	30	60	50	100
Rated Speed of Rotation	rpm	60	30	60	30	60	30	60	30	60	30	60	30	60	30	60	30
Max. Instant. Torque	Inlb	159	248	301	478	504	743	504	743	885	1416	885	1416	1947	3009	1947	3009
	Nm	18	28	34	54	57	84	57	84	100	160	100	160	220	340	220	340
Max.Speed of Rotation	rpm	100	50	80	40	80	40	80	40	80	40	80	40	80	40	80	40

nominal/peak torques and speeds



Data sheet electrical motors

■ AC drives



	unit	HKM-20-60	HKM-20-30	HKM-25-60	HKM-25-30
Rated Power	Watts	100		200	
Rated Torque	in-lb	115	223	233	440
	N-m	13	26	26	50
Maximum Torque	in-lb	345	700	830	1330
	N-m	39	79	94	150
Rated Speed	r/min	60	30	60	30
Maximum Speed	r/min	80	40	80	40
Current Rated	A	1.8	1.4	4.8	3
Current Max	A	5	4	14	9
Thermal Time Constant	min.				
Gear Reduction Ratio	R:1	50	100	50	100
Output Resolution	P/rev	50,000	100,000	75,000	150,000
	arc sec	26	13	17	9
Absolute Accuracy	+/- arc sec	75	40	60	40

- for applications requiring a rapid and accurate response, e.g., robotics
- induction motors driven by alternate current (AC)
- small diameter rotors, with low inertia for fast starts, stops, and reversals

Exploded view of a joint in the DLR-III robot

