

M6 THREAD
use 90 degr angle drill

as short as possible

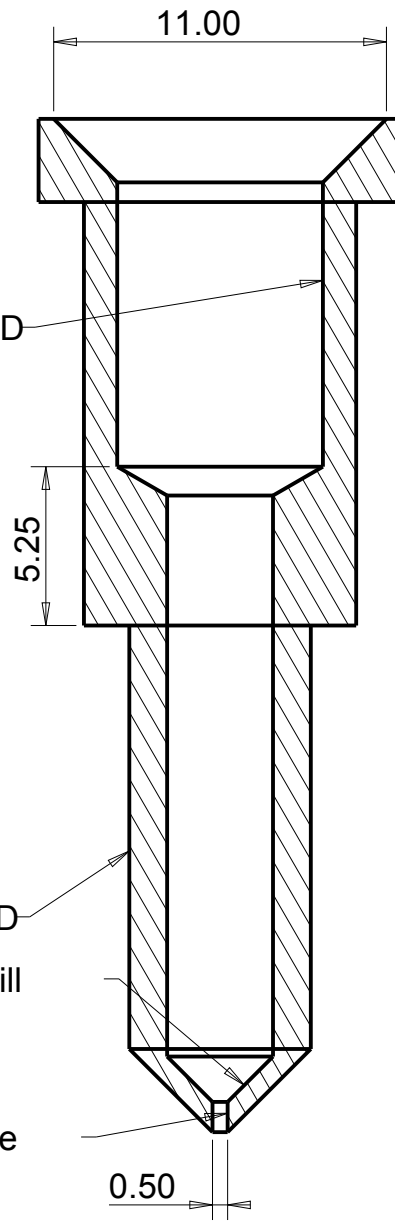

SECTION A-A

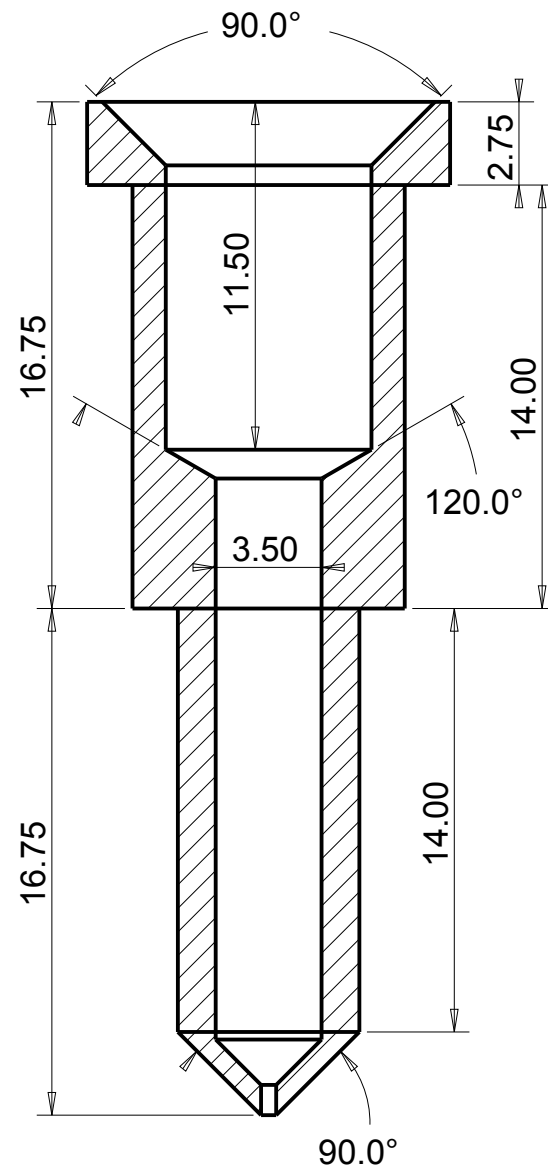

SECTION A-A

SCALE 4:1

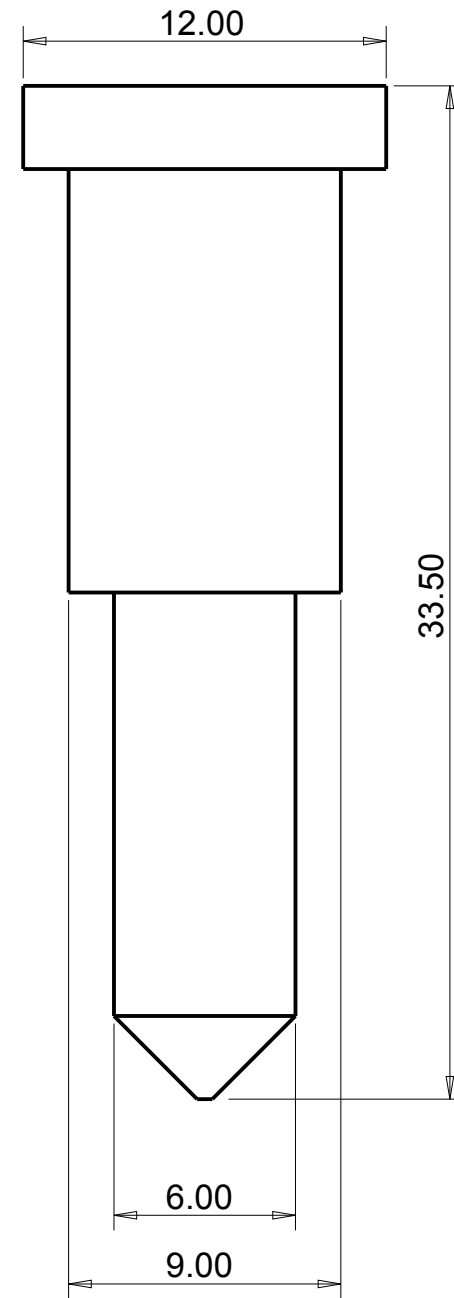

This drawing comes with a 3D CAD file with the same name. The CAD file is leading for tooling and production, the drawing is for reference only.

Nozzle v5 - 2.9mm filament and 0.50mm nozzle
Drawn by Camiel Gubbels
Date: 7 Jan 2011