

Modularity in Design of Products and Systems

Chun-Che Huang and Andrew Kusiak, *Member, IEEE*

Abstract—Modularity refers to the use of common units to create product variants. As companies strive to rationalize engineering design, manufacturing, and support processes and to produce a large variety of products at a lower cost, modularity is becoming a focus. However, modularity has been treated in the literature in an abstract form and it has not been satisfactorily explored in industry. This paper aims at the development of models and solution approaches to the modularity problem for mechanical, electrical, and mixed process products (e.g., electro-mechanical products). To interpret various types of modularity, e.g., component-swapping, component-sharing, and bus modularity, a matrix representation of the modularity problem is presented. The decomposition approach is used to determine modules for different products. The representation and solution approaches presented are illustrated with numerous examples. The paper presents a formal approach to modularity allowing for optimal forming of modules even in the situation of insufficient availability of information. The modules determined may be shared across different products.

Index Terms—Algorithms, design automation, modeling, modular products and systems, product development.

I. INTRODUCTION

THE TERM *modularity* is used to describe the use of common units to create product variants. It aims at the identification of independent, standardized, or interchangeable units to satisfy a variety of functions. With wide-ranging overall functions, the partitioning of the product into *function-oriented* modules is important, while with a small number of overall function variants, a *production-oriented* resolution is the paramount consideration [1], [2]. Function modules help to implement technical functions independently or in combination with other functions. Production modules are designed independently of their function and are based on the production based consideration alone. Function modules are classified as *basic*, *auxiliary*, *adaptive*, and *nonmodules* [3].

- *Basic module* is a module implementing *basic functions*. The basic functions are not variable in principle and are fundamental to a product or system.
- *Auxiliary module* corresponds to *auxiliary functions* that are used in conjunction with the basic modules to create various products.
- *Adaptive module* is a module in which *adaptive functions* are implemented. The adaptive functions adapt a part

or a system to other products or systems. The adaptive modules handle unpredictable constraints.

- *Nonmodule* implements *customer-specific functions* that do occur even in the most careful design development. The nonmodules have to be designed individually for specific tasks to satisfy the customer needs.

Based on the interactions within a product, three categories of modularity have been defined [4].

- *Component-swapping modularity* occurs when two or more alternative *basic components* can be paired with the same modular components creating different product variants belong to the same product family.
- *Component-sharing modularity* is the complementary case to component-swapping modularity. With various modular components sharing the same *basic component* create different product variants belonging to different product families.
- *Bus modularity* is used when a module with two or more interfaces can be matched with any number of the components selected from a set of *basic components*. The module interfaces accept any combination of the *basic components*. Bus modularity allows variation in the number and location of the basic components in a product while component-swapping and component-sharing modularity allows only variation in the types of basic components.

Design may be considered as the process of conversion of information [3]. The sufficiency of information available is crucial in identifying modules. The type and amount of information available warrants the classification of modularity based on the phases of the design process, e.g., conceptual design or detailed design modularity. The modularity considerations may depend on the type of the product, e.g., mechanical, electrical, or software. The four main phases of the design process for mechanical products are as follows [3].

A. Clarification of the Task Phase

This phase involves the collection of information about the requirements to be embodied in the design and constrains.

B. Conceptual Design

The conceptual design phase involves the establishment of functions that make up a product or a system. The conceptual elements of the products may correspond to *mechanisms* or *subsystems*. The interaction between mechanisms (subsystems) corresponds to the function inputs/outputs between mechanisms (subsystems).

Manuscript received December 22, 1995; revised September 9, 1996 and April 7, 1997. This work was supported by the National Science Foundation under Grant DDM-9215259.

The authors are with Intelligent Systems Laboratory, Department of Industrial Engineering, University of Iowa, Iowa City, IA 52242-1527 USA (e-mail: ankusiak@icaen.uiowa.edu).

Publisher Item Identifier S 1083-4427(98)00126-X.

C. Embodiment Design

During this phase of mechanical product (system) design, the designer, starting from the concept, determines the layout and form of the product (system) in accordance with technical and economic considerations. The embodiment element of products may correspond to a set of parts (components). The interaction between components corresponds to the location and size of components, spatial compatibility, etc.

D. Detail Design

In this phase, the arrangement, form, dimensions and surface of all individual components are finally laid down and all components are formally identified.

It is desirable to form modules early in the design process, e.g., at the conceptual design phase. However, the information to identify the modules might not be available at the early design phase, e.g., the definition of the suitability matrix discussed in Section II. This may cause that modules generated too early in the design process might not meet the constraints that become apparent later in the design process.

Potential benefits of modularity include [3], [5], [6]:

- economy of scale;
- increased feasibility of product/component change;
- increased product variety;
- reduced order leadtime;
- decoupling risk;
- the ease of product diagnosis, maintenance, repair, and disposal.

As companies strive to rationalize their manufacturing facilities and to produce a large variety of products at lower cost, modularity, due to its benefits, is becoming a focus of attention and frequently stated as a goal of good design practice [3]. However, modularity has not received sufficient attention in literature [3], [4], [7]. It has not been explored in industry to the same degree as, for example, design for manufacturing. Approaches to determine modules, represent modularity, optimize modular designs, and assess the impact of modularity on the design process, manufacturing, and management needs to be explored. This paper aims at the development of models and solution approaches to the modularity problem for mechanical, electrical, and mixed process products (e.g., electromechanical products). The remainder of this paper is organized as follows. Section II presents a matrix representation of the modularity problem and provides an interpretation of the three types of modularity. Section III defines the modularity problem. Section IV discusses the decomposition approach for solving the modularity problem. The representation and solution approaches presented are illustrated with examples for electrical, mechanical, and electromechanical products at the conceptual and detailed phases in Section V. Section VI concludes the paper and outlines further research directions.

The main contribution of this paper is in the development of a formal approach for the definition of modules, representation of modularity, and the development of generic modular products, e.g., electrical, mechanical, and electromechanical products with the consideration of cost and size of the modules. Other concerns, e.g., performance attributes of a module, and

the interaction between product modularity and testability, are discussed in [8] and [9], respectively.

II. MODELING THE PRODUCT MODULARITY

In this section, modular products are represented with two matrices, an interaction matrix and a suitability matrix. Different types of modularity are interpreted based on the two matrices. The matrix formulation has been applied broadly in manufacturing, e.g., in the group technology, process planning, and scheduling problems [10].

A. Representation of Modular Products

Modularity is viewed by Ulrich and Tung [4] as depending on two characteristics of design:

- 1) similarity between the physical and functional architecture of the design;
- 2) minimization of incidental interactions between physical components.

The characteristics above imply two types of relationships involved in the modularity concept:

- 1) similarity of the functional interactions within a module;
- 2) suitability of inclusion of components in a module.

Based on the two relationships, the interaction and suitability matrix are used to represent modular products.

Let the row set I and the column set J correspond to the component set $C = \{1 \cdots m\}$ in the two matrices.

The *interaction matrix*, $A = [a_{ij}]_{m \times m}$, is a component–component incidence matrix, where a_{ij} represents the interaction between component i and component j ; i and $j \in C$.

The *suitability matrix*, $B = [b_{ij}]_{m \times m}$, is a component–component incidence matrix, where b_{ij} represents the suitability of components i and j for inclusion in a module; i and $j \in C$.

Let $A' = [a'_{ij}]_{m \times m}$ be the matrix with the rows and columns rearranged by the decomposition algorithm presented in Section III for easy identification of modules.

Let $B' = [b'_{ij}]_{m \times m}$ be the matrix with the rows and columns arranged in the order as the rows and columns of A' .

The *modularity matrix* is defined as $[A'|B']_{m \times 2m}$.

The *modules* correspond to the groups of entries identified in A' . The components that do not belong to any module are *independent components*. Independent components may be basic components that jointly with modular components result in different types of modular products.

Fig. 1 shows an example of the modularity matrix. The columns and rows correspond to component numbers. An entry “1” corresponds to the interaction between two components and “blank” indicates no interaction. An entry “a” implies the suitability of two components for inclusion in a module, and “o” indicates nonsuitability. Three modules are identified in Fig. 1. Components 7, 2, and 9 are the basic components.

Due to the varying degree of information availability at different phases of the design process, the component set considered may correspond to a subsystem (mechanism) set at the conceptual design phase or a part set at the detail design

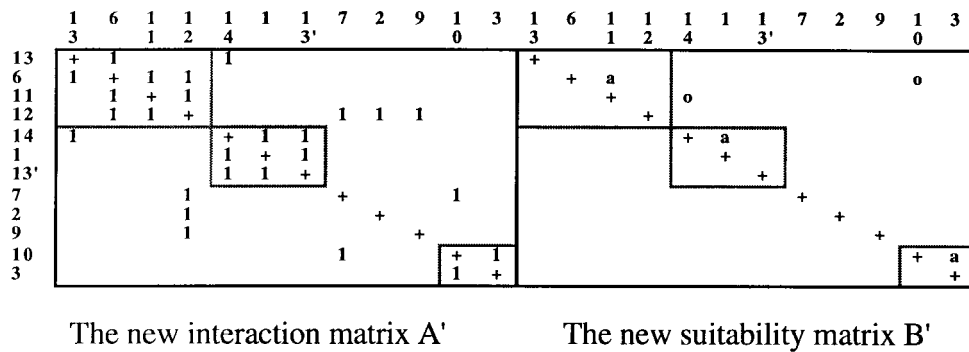

Fig. 1. Modularity matrix.

TABLE I
SUMMARY OF APPLICATIONS OF THE MODULARITY MATRIX

Design phase	Product type	Interaction matrix			Suitability matrix
		Entry interpretation	Column name	Entry value: value interpretation	Entry value: value interpretation
Conceptual phase	All	Function flow	Mechanism/Subsystem	Integer number: frequency of application	a: strongly desired e: desired o: strongly undesired u: undesired
Detailed phase	Electrical	Electrical flow	Component		
	Mechanical	Force flow, thermal, function, etc.			
	Mixed	Force flow, thermal, function, etc.			

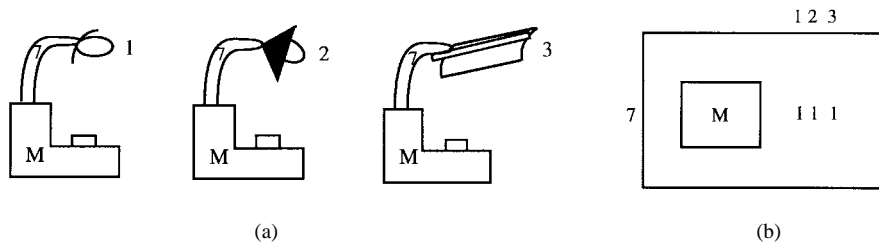

Fig. 2. Example of component-swapping modularity: (a) modular products and (b) matrix representation.

phase. The entries in the interaction matrix may be generalized to integer numbers representing, e.g., the frequency of application of any two functions at the conceptual design phase, or two components at the detailed design phase. The summary of entry values, their interpretation, and the meaning of the column and row labels in the modularity matrix applied to different types of products and at different design phases are summarized in Table I.

B. Interpretation of Different Types of Modularity

The modularity matrix allows the representation of the different types of modularity that are interpreted next.

Axiom 1 interprets the component-swapping modularity.

Axiom 1: Let C_i be the set of columns corresponding to entries “1” of row i [e.g., $C_7 = \{1, 2, 3\}$ in Fig. 2(b)].

If

- 1) row i corresponds to a module, and
- 2) columns $j \in C_i$ do not correspond to any other module

then the modularity is referred to as the *component-swapping modularity*, e.g., module M and the set $C_7 = \{1, 2, 3\}$ in Fig. 2(b) form the component-swapping modularity.

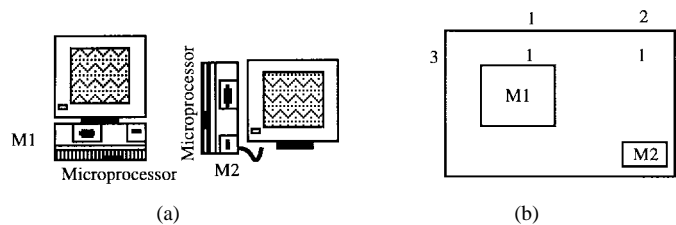
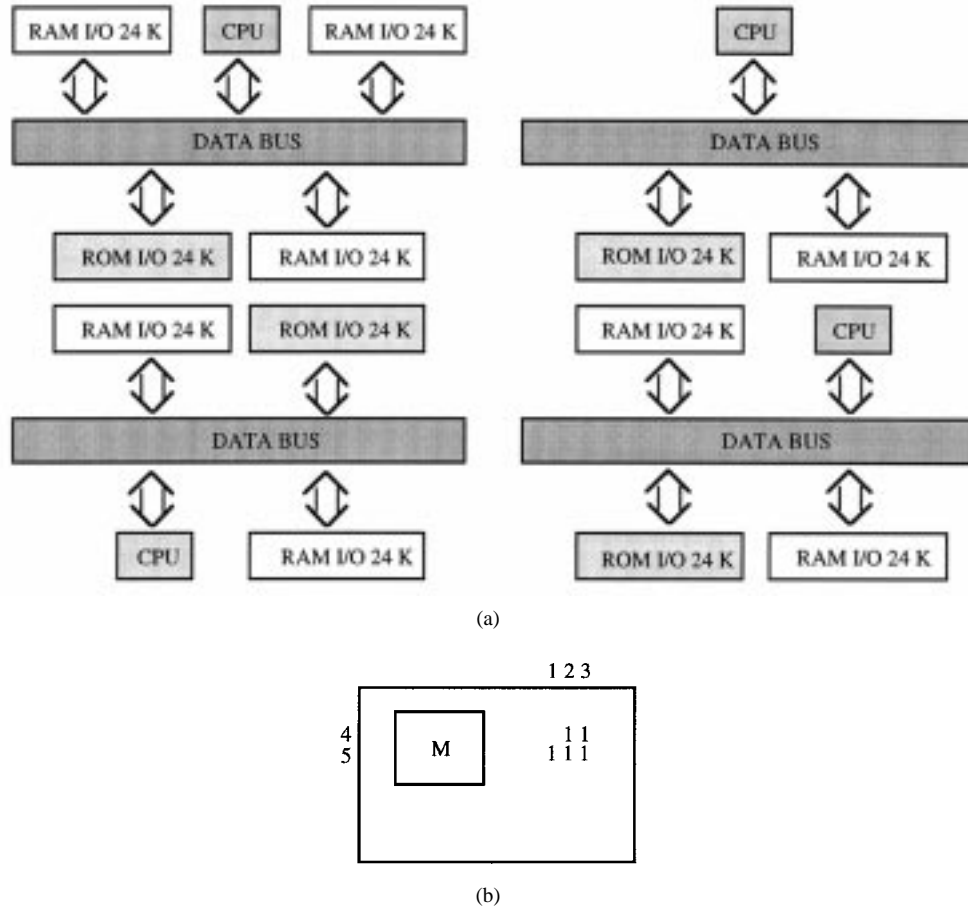

Fig. 3. Example of component-sharing modularity: (a) modular products and (b) matrix representation.

Example 1: An example of product variants generated through component-swapping is provided in Fig. 2(a). The multifunctional office desk lamp in Fig. 2(a) is assembled on a base (M). Different product variants are produced by changing the fixture (basic components 1, 2, and 3).

In the automotive industry, by using different audio cassette decks, windshield glass, and wheel types with the same base body of the car, different models of cars are generated. In computer industry, the component-swapping modularity manifests itself through matching of different hard disk types, monitor types, and keyboards with the same frame board.



Axiom 2 is used to interpret the component-sharing modularity.

Axiom 2: Let C_i be the set of columns corresponding to entries “1” of row i [e.g., $C_3 = \{1, 2\}$ in Fig. 3(b)].

If

- 1) row i corresponds to a basic component, and
- 2) each column in C_i corresponds to a module

then the modularity is referred to as the *component-sharing modularity*, e.g., modules $M1$ and $M2$, and component 3 in Fig. 3(b) form the component-sharing modularity.

Example 2: An example of product variants generated through component-sharing is provided in Fig. 3(a). The different types of frame boards and monitors ($M1, M2$) in Fig. 3(a) sharing the same microprocessor (component 3) make up different types of computers.

The component-sharing modularity in automotive manufacturing leads the uses of same brake shoes, alternators, or spark plugs in different product families. In consumer electronics, component-sharing arises when a common power cord or a common tape transport mechanism is used in different product families.

Axiom 3 interprets the bus modularity.

Axiom 3: Let C_i be the set of columns corresponding to entries “1” [e.g., $C_5 = \{1, 2, 3\}$ in Fig. 4(b)] and R_i be the set of rows corresponding to entries “1” [e.g., $R_4 = R_5 = \{4, 5\}$ in Fig. 4(b)].

If

- 1) the set of rows R_i corresponds to a module, and
- 2) all columns $j \in C_i$ do not correspond to any other module

then the modularity as referred to is the *bus modularity*, e.g., module M and basic components 1, 2, and 3 in Fig. 4(b) form the bus modularity.

Example 3: An example of product variants generated through the bus modularity is provided in Fig. 4(a). The same type of data bus (M), and different types of CPU and memory units (components 1, 2, 3) in Fig. 4(a) form different types of data processors with RAM/ROM of different capacity.

Other examples of bus modularity are computer and circuit breaker systems, gantry robot systems, and storage/retrieval systems, which use auxiliary components of different types to handle variety of objects.

III. MODULARITY PROBLEM

In this paper, modularity refers to the decomposition of the architecture of a product family into distinct building blocks (modules) used to meet various functions of the products. The *architecture* of a product is the scheme by which its functional elements are arranged and interact.

The modularity problem represented with a the modularity matrix is formulated next.

Decompose a component–component interaction matrix into mutually separable submatrices (modules) with

- 1) the minimum number of nonempty high value entries outside the block-diagonal interaction matrix, and
- 2) the maximum number of strongly desired entries (denoted as a) and minimum number of strongly undesired entries (denoted as o) included in the submatrices of the block diagonal suitability matrix

subject to the following constraints:

Constraint C1: Empty modules of components are not allowed, and;

Constraint C2: The number of components in a module cannot exceed the upper bound N_u , and the total cost of the components duplicated cannot exceed B .

Constraint C1 is trivial. Constraint C2 limits the size of a module compromised due to several factors, e.g., the panel size, performance requirements, cost, or testability. For aerospace products weight, rather than cost, might be a factor to be considered.

IV. DECOMPOSITION APPROACH

The decomposition approach presented in this section transforms the interaction and suitability matrices into matrix A' and B' (defined in Section II), analyzes the modularity matrix, and detects modularity in a product set. Some research on the application of decomposition in engineering design has been reported in the literature [11]–[15]. As the interaction matrix is a square matrix, the triangularization algorithm [16] is applied to identify the modules. The constraints imposed by the suitability matrix and other factors are considered. Decomposition allows one to explore potential modules among components and to analyze various types of modularity. The challenge is to group components into modules that are of acceptable size or cost.

A. Algorithm

Step 0. Initialization: Initialize the interaction and suitability matrix. Specify the upper bound N_U on the number of components in a module and budget B .

Step 1. Triangularization: Triangularize the interaction matrix A into matrix A' with the algorithm presented in Kusiak *et al.* [16].

Step 2. Rearrangement: Rearrange the suitability matrix B into matrix B' so that sequence of columns and rows in matrix B' is same as in matrix A' .

Step 3. Combination: Combine the matrix A' and the matrix B' into the modularity matrix $[A'|B']$. Identify modules corresponding to the groups in A' .

Step 4. Deletion: Remove a component from a module that satisfies Condition 1, and place it in the last column of the modularity matrix. Repeat this step until no more components can be removed.

Step 5. Duplication: Duplicate a component that satisfies Condition 2, and repeat this step until no more components can be duplicated.

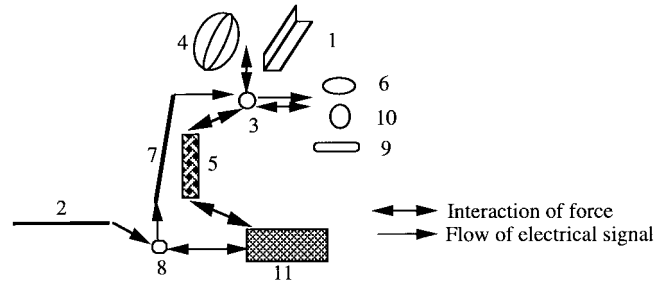

Fig. 5. The schematic representation of the desk lamps from Fig. 2.

Step 6. Classification: Analyze the modularity matrix to classify the modules based on the three axioms presented in Section II.

Step 7. Termination: Stop and output the results.

Condition 1: Remove a component, say k , if the following conditions are satisfied.

- 1) Component k and any other component, l , in the same module are strongly undesired for inclusion in the module, i.e., an entry in the submatrix of matrix B' is set to “0”.
- 2) Component k interacts with the remaining components in the module to a lesser degree than component l , i.e., the total of row entries corresponding to component k is smaller than the total of row entries corresponding to component l in the submatrix of matrix A' .
- 3) None of the submatrices violates constraints C1 and C2.

Condition 2: Duplicate the component if the following conditions are satisfied.

- 1) The component that is used and strongly desired for inclusion in two modules simultaneously, i.e., some entries in the submatrices of matrix B' are set to “a”.
- 2) None of the submatrices violates constraints C1 and C2.

Note that in Step 4 the components that are undesired in a module are removed (see Example 6). Step 5 produces a solution of better quality by duplicating some components. Duplicating the overlapping components in the modularity matrix may lead to mutually separable modules. The benefits resulting from the duplication of elements in matrix decomposition are discussed in [17].

V. ILLUSTRATIVE EXAMPLES

Depending on the design phase and the product type, the interpretation of the rows and columns of the modularity matrix varies. In this section, examples illustrating modularity representations at the conceptual and detailed design phases are provided.

A. Conceptual Design Phase

The conceptual design phase leads to a design object described schematically with a graph of functional elements and their interconnections [18]. The interaction matrix represents the functionality of subsystems (mechanisms). A functional element corresponds to a subsystem (mechanism), and in-

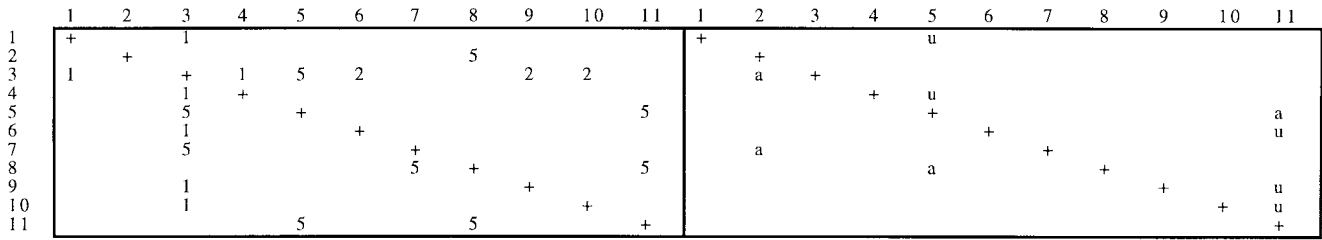

Fig. 6. Two matrices for the components of the lamp in Fig. 5.

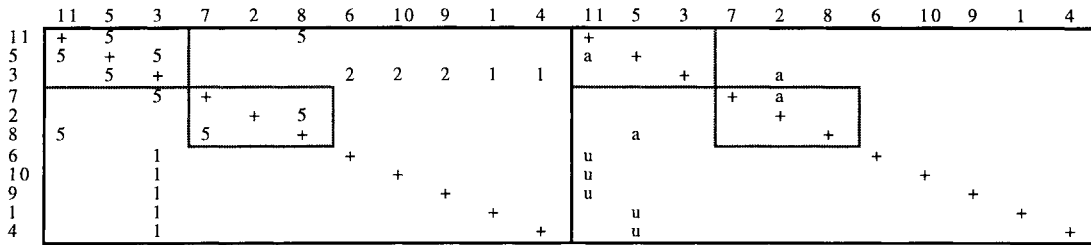

Fig. 7. The modularity matrix for the lamp in Fig. 5.

terconnections correspond to function flows in the function-oriented modularity representation.

Example 4. Electrical Products: Consider a conceptual design of the desk lamp in Fig. 5.

- components 1 and 4 are the different covers of the lamp;
- components 2 and 7 are internal and external electrical cords, respectively;
- component 3 is an internal connector;
- component 5 is the lamp stand;
- components 6, 9, and 10 are different bulbs;
- component 8 is the switch;
- component 11 is the base.

Note that the force interaction is considered as bidirectional and the electrical flow as unidirectional. The interaction matrix and the suitability matrix for the components of the lamp in Fig. 5 are defined in Fig. 6.

Note that $a_{5,3} = "5"$, which means that the force from component 5 to component 3 appears in five different designs of the lamp.

Applying the decomposition approach presented in Section III to the modularity problem of the desk lamp, the resulting modularity matrix $[A'|B']$ is as follows (Fig. 7).

In the modularity matrix in Fig. 7, two modules are identified: $M1 = \{11, 5, 3\}$ and $M2 = \{7, 2, 8\}$. Module $M1$ and components 1 and 4 form a component-swapping modularity. Module $M2$ and components 6, 10, and 9 form also component-swapping modularity.

B. Detailed Design Phase

The functional space (conceptual design) maps into physical components (detailed design) with specified features. Based on the features, six types of similarity (called *feature similarity*) are considered in the identification of modular parts: geometric, temporal, force, electrical, thermal, and photometric [3].

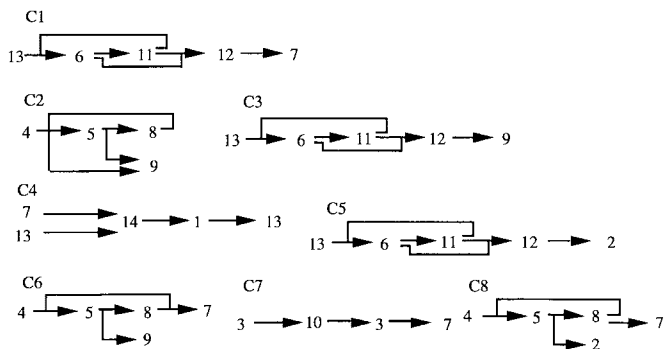

Fig. 8. The set of electrical components with inputs and outputs.

The feature similarity is represented by the interaction matrix at the detailed design phase.

C. Electrical Design

An electrical product, whether it is a simple transistor radio or a complex supercomputer, consists of two basic elements: the electronic components and the interconnections between components. In the modularity problem for electrical products, the inputs/outputs of the components and the interaction among the components are considered.

Example 5. Electrical Circuits: Consider the set of electrical components $C1, C2, C3, C4, C5, C6, C7,$ and $C8$ in Fig. 8.

The interaction matrix and the suitability matrix of the component set are defined in Fig. 9.

Entry $a_{5,1} = "1"$, which means that the electrical signal flows from output 5 to input 1. Applying the decomposition approach presented in Section III to the modularity matrix in Fig. 9 results in matrix $[A'|B']$ in Fig. 10.

Four modules have been identified in the matrix in Fig. 10: (13, 6, 11, 12), (13', 14, 1), (10, 3), and (4, 5, 8). Based on the definitions presented in Section II, module (6, 11, 12, 13)

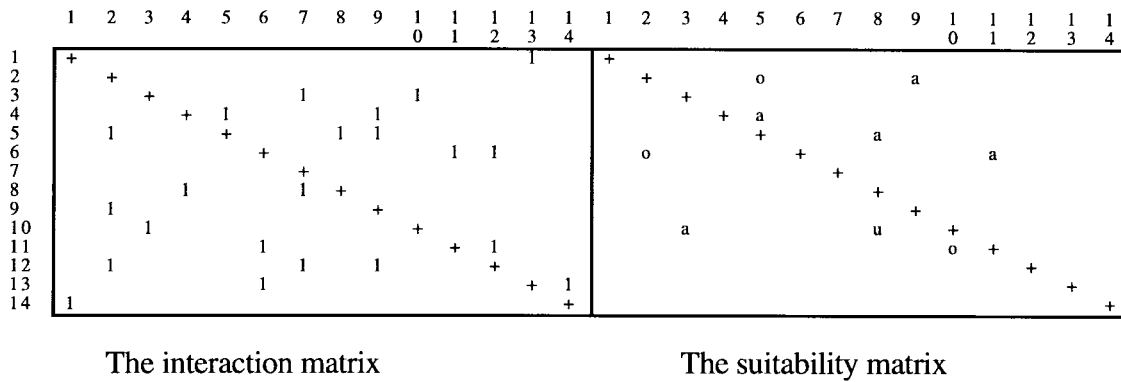

Fig. 9. The interaction matrix and the suitability matrix for the eight components in Fig. 8.

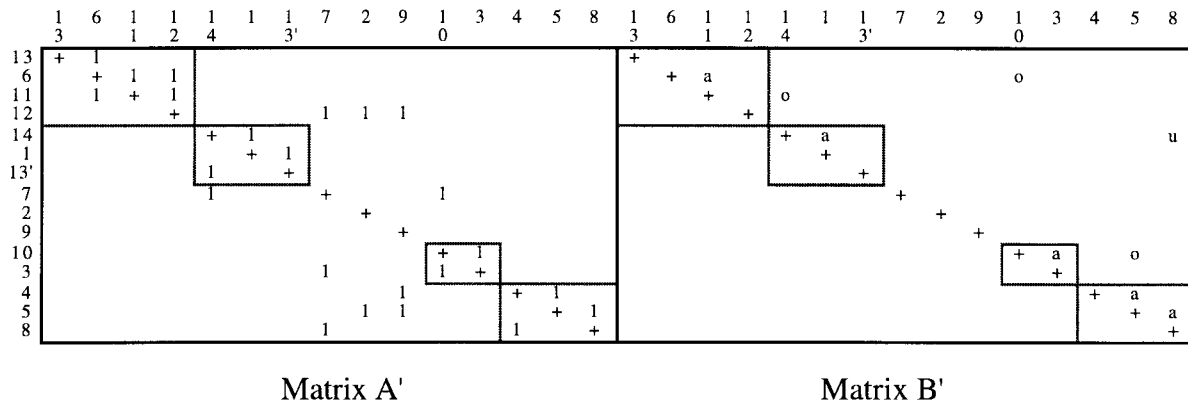

Fig. 10. The transformed modularity matrix.

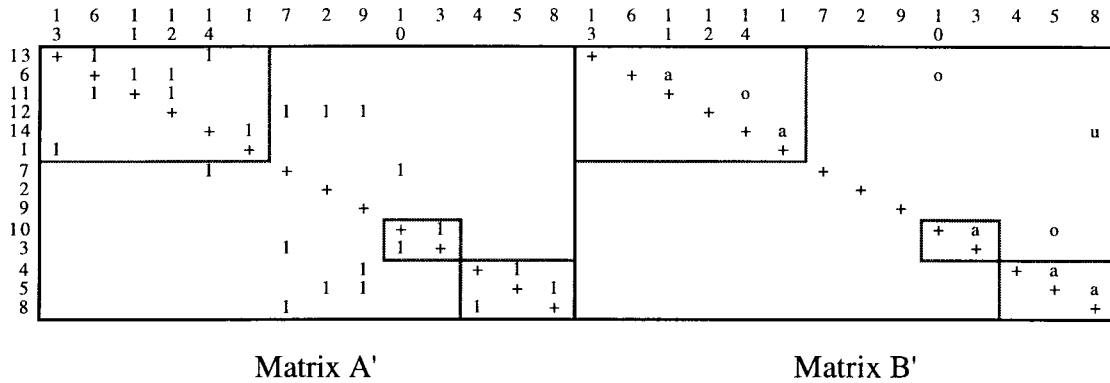

Fig. 11. The transformed modularity matrix without duplicating 13.

and components 7, 9, 2 form component-swapping modularity. Module (13, 14, 1), (10, 3) and component 7 form component-sharing modularity. Module (4, 5, 8) and components 2, 7, 9 form bus modularity.

Note that in order to obtain a solution of better quality, input 13' duplicates 13. The modularity matrix without duplicating 13 is presented in Fig. 11. Three modules are identified: (13, 6, 11, 12, 14, 1), (10, 3), and (4, 5, 8), where the submatrix corresponding to module (13, 6, 11, 12, 14, 1) is a low-density matrix. The group efficacy of module (13, 6, 11, 12, 14, 1) = 8/36 is lower than the group efficacy of modules (13, 6, 11,

12) and (14, 1, 13') = 5/16 + 3/9 = 93/144 in Fig. 10 (see [19] for the detail of the efficacy measure).

Examples of the designs based on the modules identified in Fig. 10 are shown in Fig. 12. The shadowed components form the modules.

D. Mechanical Design

Besides the functional interactions, the geometric interactions need to be considered in mechanical design. According to Kameyama [20], the shape, properties, and manufacturing process data should be considered for the geometric interaction

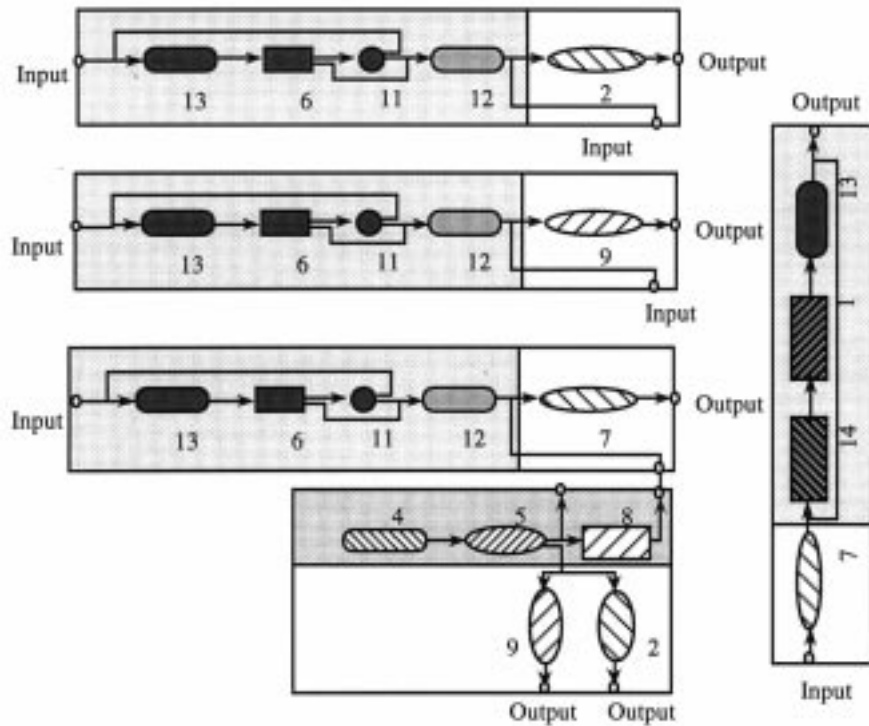

Fig. 12. Example of five electrical circuits.

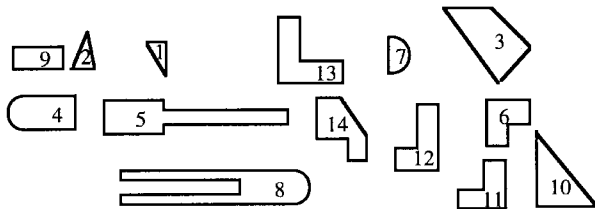

Fig. 13. The shapes of mechanical components.

among components. In the mechanical design, the geometric interaction matrix represents the coupling of components of different shapes. The suitability matrix represents the suitability of distinct components for inclusion in a module.

Example 6. Mechanical Product: Consider the 14 mechanical components in Fig. 13.

The interaction matrix and the suitability matrix of this component set are defined as in Fig. 14.

The components are to be assembled into different products. Components 6, 11, 12, and 13 are made of material A, and components 4, 5, and 8 are made of material B. Material A cannot be glued to material B. Components 7, 2, and 9 can be glued to any material. In the modularity matrix, the entries $b_{6,4}$, $b_{11,5}$, $b_{12,8}$, are set to “o”, and the entries $b_{11,12}$, $b_{11,7}$, $b_{12,2}$ are set to “a”. The entry $a_{14,1} = “2”$ represents that components 14 and 1 appear in two different assemblies.

The transformed modularity matrix $[A'|B']$ at the detailed design phase is presented in Fig. 15.

Four modules have been identified in the matrix in Fig. 14: (13, 6, 11, 12), (7, 14, 1), (10, 3), and (4, 5, 8). Based on the definitions from Section II, module (6, 11, 12, 13)

and components 7, 9, 2 form the component-swapping modularity. Module (4, 5, 8), (10, 3) and component 2 form the component-sharing modularity. Module (4, 5, 8) and components 2, 7, 9 form the bus modularity.

Note that component 14, a fuzzy component that may be in module (12, 6, 11, 12) or (1, 7), is excluded from module (13, 6, 11, 12) due to inconsistent characteristics of material between components 14 and 13 (see Fig. 16). In step 4, the use of deletion based on the suitability matrix aims at the determination of the module size.

Examples of the resulting product structures are shown in Fig. 17. The shadowed components are the modules identified in Fig. 15.

E. Electromechanical Design

In some areas of engineering design, e.g., design of electrical circuits, formal representations exist for the artifacts used in design which capture their important physical, functional, and logical attributes. A fundamental concern in mechanical and electro-mechanical design is that complete representations do not exist for mechanical artifacts [21].

The general definition of feature is such as “a feature is any entity used in reasoning about the design, engineering, or manufacturing of a product” [22]. The similarity of features of components in a mixed-type product is used to determine the modules. For the detailed design of mixed-type products, the six types of feature similarities are considered in the interaction matrix. Based on each type of feature similarity, an interaction matrix is constructed, e.g., the electrical interaction matrix is constructed based on electrical similarity. The final interaction matrix is obtained by combining the single feature matrices.

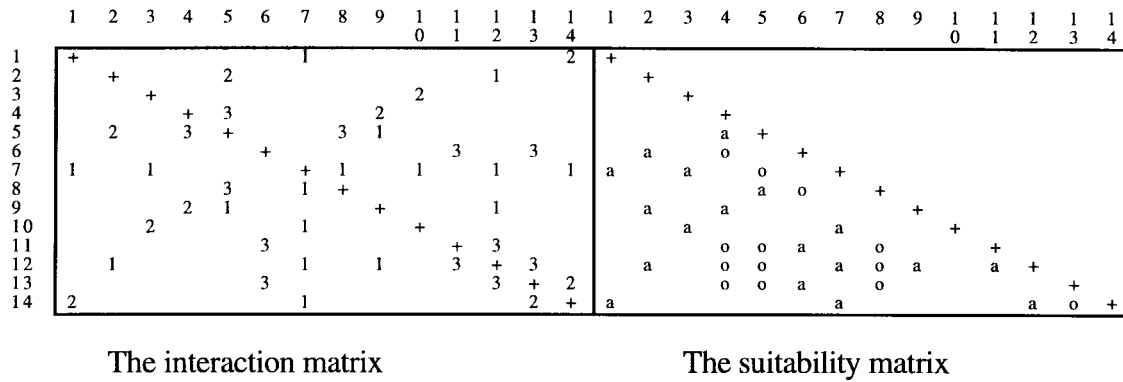

Fig. 14. The interaction matrix and the suitability matrix of 14 mechanical components.

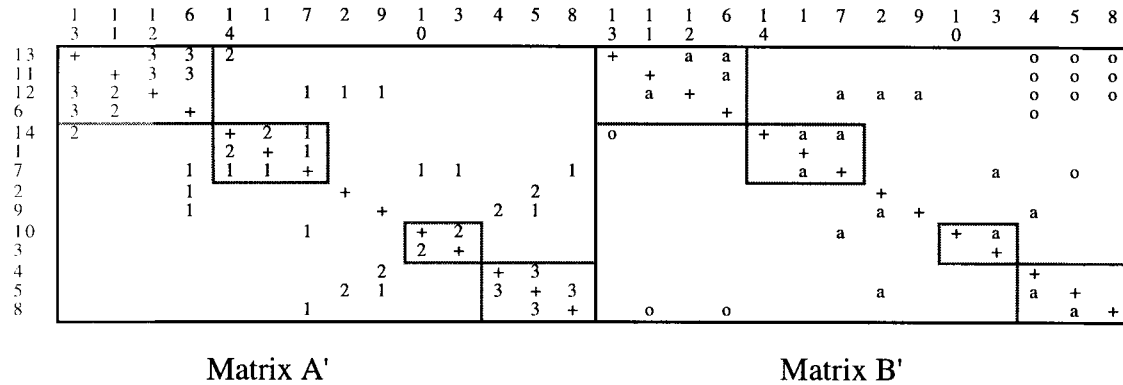

Fig. 15. The modularity matrix for 14 mechanical components: (a) matrix A' and (b) matrix B'.

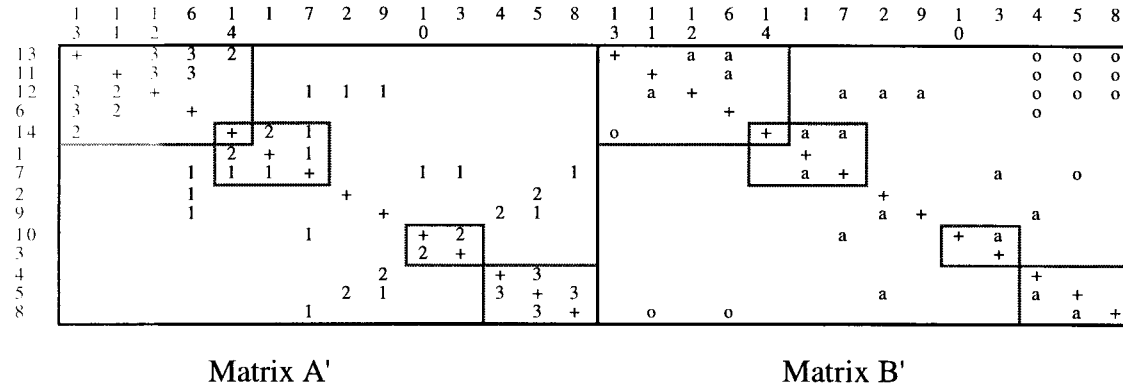

Fig. 16. The modularity matrix before Step 4, deleting component 14: (a) matrix A' and (b) matrix B'.

Example 7. Electric Motor Design: Consider the following components of the electric motor:

- component 1: base frame;
- component 2: rotor lamination;
- component 3: terminal box;
- components 4, 13: different types of top cover plate;
- components 5, 8: different types of winding;
- component 6: bearing;
- component 7: stator lamination;
- components 9, 10: different types of support frame;
- component 11: stator winding;
- components 12, 16: different types of ventilation grid;

- component 14: side cover plate;
- component 15: rotor;
- component 17: winding cover;
- component 18: stator housing;
- component 19: shaft.

Fig. 18 illustrates the components of the electric motor. The interaction matrix of the electric motor is produced by combining the force, electrical, and thermal interaction matrices as follows (*s*: the force interaction; *m*: electrical interaction; *t*: thermal interaction; integer number: the frequency of application) (see Fig. 19).

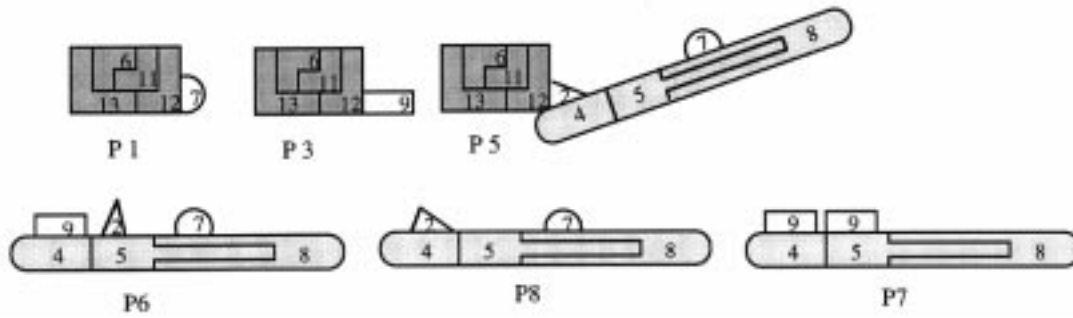

Fig. 17. Example of the modular products with 14 mechanical components.

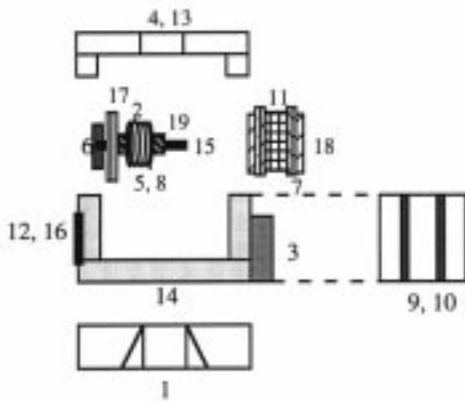

Fig. 18. Electric motor.

Two examples of entries defined in the suitability matrix of the electric motor are shown next.

- 1) The electrical windings (components 5 and 8) must be isolated from the side and top cover plates (components 4, 13, 14), and the base frame (component 1) to avoid a possible leak of electricity. The latter implies that in the suitability matrix the following entries must be set as 0's (strongly undesired): $b_{1,5}$, $b_{1,8}$, $b_{5,14}$, $b_{8,14}$, $b_{5,13}$, $b_{8,4}$, and so on.
- 2) The rotor lamination, shaft, and rotor are strongly desired to be included in a module because of strong functional interaction; same applied to the stator winding, stator lamination, and stator housing.

The suitability matrix of the electric motor is defined in Fig. 20.

Note that at the detail design phase, the entries of the suitability matrix are easier to identify than in the conceptual phase as more information is available. This causes that the suitability matrix in Fig. 20 is more dense than the suitability matrix in Fig. 6 at the conceptual design phase.

Applying the decomposition approach from Section III to the modularity problem represented in Fig. 20 results in the interaction matrix (matrix A') and suitability matrix (matrix B') in Figs. 21 and 22, respectively.

Three modules are identified in the matrix in Fig. 19: $M1 = \{\text{base frame, terminal box, side cover plate}\}$, $M2 = \{\text{stator winding, stator lamination, stator winding}\}$, and $M3 = \{\text{winding cover, shaft, rotor lamination, bearing, rotor}\}$. Module $M1$ and parts 4, 13 form component-swapping modularity.

Also module $M1$ and parts 12, 16, 9, and 10 form component-swapping modularity. Module $M3$, parts 5, 8, and parts 4, 13 form bus modularity. The combination of different types of top and side cover plates, windings, and ventilation grids produces various types of three-phase motors, specifically with different output powers.

F. Discussion

Thus modular product design is an important form of *strategic flexibility* [23], i.e., flexible product designs allow a company to respond to the changing markets and technologies by rapidly and inexpensively creating product variants derived from different combinations of the existing or new modular components. Modular product design supports the goals of the concurrent engineering aiming at the reduction of the product development time and cost by developing the modules concurrently. The matrix representation presented in Section II offers flexibility in terms of subsystem and parts in the formation of modular products (see Table I). The decomposition approach aims at separating the product architecture into modules to be developed concurrently. In this way, products can be designed more effectively. As soon as the modules are formed at the conceptual phase, detailed design of modules should be initiated. The frequency matrix may have a profound effect on eliminating inconsistencies (see Table I), e.g., assembly of inconsistent material or geometry constraints, as the components with high degree of interaction are likely to be included in the same module.

The distributed collaborative design through the Internet appears to be feasible in a modern design environment. To speed up the product design process, it is not necessary to design each individual module but rather use the modules that have been created. The distributed collaborative design of modular products provides an effective way to respond to the changing market requirements. The matrix representation provides a structure for the exchange of modularity data according to a standard protocol, e.g., Standard for Exchange of Product Data (STEP) [24].

VI. CONCLUSIONS

In this paper, the matrix representation of the modularity problem and the interpretation of three different types of modularity were presented. A decomposition approach was used to solve the modularity problem. The representation and

	1	2	3	4	5	6	7	8	9	10	11	12	13	14	15	16	17	18	19
1	+													s24				s24	
2		+				s24		s12							s24				
3			+											s24					
4				+		s12								s12					
5		s12			+					m12	t4					t4			
6		s24		s12		+						s12	s24						s24
7							+			m24	t4							s24	
8		s12						+		m12	t4					t4			
9									+					s12					
10						m12		m12	m12		+			s12					s24
11																			
12												+		s8					
13						s12				s12	s12		s8	s12					
14	s24		s24	s12		s24						s8	s12	+		s8			
15		s24												+		+	s24		s24
16														s8		+			
17															s24		+		
18	s24						s24			m24								+	
19						s24									s24				+

Fig. 19. The final interaction matrix of the electric motor.

	1	2	3	4	5	6	7	8	9	10	11	12	13	14	15	16	17	18	19
1	+																		
2		+																	
3			+																
4	e			+															
5	o	e		o	+														
6				e		+													
7							+												
8	o			o				+	u										
9		a			u			u	+										
10	e				u					+									
11	o			u			a		o	o	+								
12												+							
13	e			o	e		o		e	o		e	+						
14	e		a	e	o	a	e	o	e	e	o	e	e	+					
15		a												e					
16															+	e			
17		e				e			e		a					+			
18							a											+	
19		a														a		a	+

Fig. 20. The suitability matrix for the electric motor.

	1	14	3	18	7	11	17	19	2	6	15	8	13	16	5	10	4	9	12
1	+	s24		s24															
14	s24	+	s24						s24				s12	s8		s12	s12	s12	s8
3		s24	+																
18	s24			+	s24	s24													
7				s24	+	m24													
11				s24	m24	+						m12			m12				
17							+												
19								+	s24	s24									
2									s24	s24	+								
6		s24							s24	s24									
15																			
8					m12							s12							
13		s12											+		t4				t4
16		s8																	
5						m12									t4	+			
10		s12															+		t4
4		s12																+	
9		s12																	+
12		s8																	+

Fig. 21. Matrix A' for the electric motor.

	1	14	3	18	7	11	17	19	2	6	15	8	13	16	5	10	4	9	12
1	+																		
14	e	+	a		e	o				a		o	e		o	e	e	e	e
3			+																
18				+	a														
7					+														
11	o					+							o			o	u	o	
17							+		e	e	e							e	
19						a		+	a	+									
2											+								
6																			
15									a		+							e	
8	o								e			+					o		
13	e									e			o	+					
16		e													+				
5	o								e							+	o		
10	e												u			+			
4	e																+		
9									a									+	
12																			+

Fig. 22. Matrix B' for the electric motor.

solution approach presented were illustrated with examples for electrical, mechanical and electromechanical products at the conceptual and detailed design phases.

Modules should be ideally formed early in the design process, e.g., at the conceptual design phase. However, the information to identify the modules might not be available. This may cause that modules generated too early in the design process might not meet the constraints that become apparent later in the design process. Forming modules for different types of products is crucial in agile manufacturing. The paper develops a formal approach for effective design of modular products even in the situation of insufficient availability of information.

In the future, more comprehensive approaches to optimize modular designs, and the assessment of the impact of modularity on the design process, manufacturing, and management need to be explored. Besides the interactivity factor, other factors, e.g., the panel size, performance requirements, cost, or testability should be considered as multiple design goals. The exchange of modularity data in the distributed collaborative design environment needs to be studied.

REFERENCES

- [1] K. H. Borowski, *Das Baukastensystem der Technik*. Berlin, Germany: Springer-Verlag, 1961.
- [2] K. Brankamp and J. Herrmann, "Baukastensystematik—Grundlagen und Anwendung in Technik u. Organizational," *Ind.—Anzeiger*, vol. 91, no. 31/50, 1969.
- [3] G. Pahl and W. Beitz, *Engineering Design*. London, U.K.: Design Council, 1988.
- [4] K. Ulrich and K. Tung, "Fundamentals of product modularity," *Issues in Design/Manufacture Integration 1991*, A. Sharon, Ed. New York: ASME, 1991, pp. 73–79.
- [5] J. L. Nevins and D. E. Whitney, *Concurrent Design of Products & Processes: A Strategy for the Next Generation in Manufacturing*. New York: McGraw-Hill, 1989.
- [6] J. Corbett, M. Dooner, J. Meleka, and C. Pym, *Design for Manufacturing: Strategies, Principles, and Techniques*. New York: Addison Wesley, 1991.
- [7] G. V. Shirley, "Models for managing the redesign and manufacture of product sets," *J. Manuf. Oper. Manage.*, vol. 3, no. 1, pp. 85–104, 1990.
- [8] A. Kusiak and C. C. Huang, "Development of modular products," Intelligent Systems Lab., Univ. Iowa, Iowa City, working paper ISL-9616, 1996.
- [9] ———, "Design of modular digital circuits for testability," *IEEE Trans. Comp., Packag., Manufact. Technol. C*, vol. 20, pp. 48–57, Jan. 1997.
- [10] A. Kusiak, *Intelligent Manufacturing Systems*. Englewood Cliffs, NJ: Prentice-Hall, 1990.
- [11] D. V. Steward, "Partition and testing systems of equations," *J. Soc. Ind. Appl. Math.: Numer. Anal.*, vol. 2, no. 2, pp. 345–365, 1965.
- [12] H. Zarefar, T. J. Lawley, and F. Etesami, "PAGES: A parallel axis gear drive expert system," in *Proc. ASME Computers Engineering Conf.*, 1986, pp. 145–149.
- [13] S. D. Eppinger, D. E. Whitney, R. O. Smith, and D. A. Gebala, "Organizing the tasks in complex design projects," in *Proc. 1990 ASME Conf.—Design Theory Methodology*, J. R. Rinderle, Ed., 1990, pp. 39–46.
- [14] A. Kusiak and K. Park, "Concurrent engineering: Decomposition and scheduling of design activities," *Int. J. Prod. Res.*, vol. 28, no. 10, pp. 1883–1900, 1990.
- [15] R. P. Smith and S. D. Eppinger, "Modeling design iteration," Sloan School Manage., Mass. Inst. Technol., Cambridge, working paper 3160-90-MS, 1990.
- [16] A. Kusiak, T. Larson, and J. Wang, "Reengineering of design and manufacturing processes," *Comput. Ind. Eng.*, vol. 26, no. 3, pp. 521–536, 1994.
- [17] A. Kusiak and J. Wang, "Decomposition of the design process," *J. Mech. Design*, vol. 115, no. 12, pp. 687–695, 1993.
- [18] K. Ulrich and W. P. Seering, "Synthesis of schematic descriptions in mechanical design," *Res. Eng. Design*, vol. 1, no. 1, pp. 3–18, 1989.
- [19] C. S. Kumar and M. P. Chandrasekharan, "Group efficacy: A quantitative criterion for goodness of block diagonal forms of binary matrices in group technology," *Int. J. Prod. Res.*, vol. 28, no. 2, pp. 233–244, 1990.
- [20] K. K. Kameyama, "Real-time constraint checking in the design process," in *Concurrent Engineering: Automation, Tools, and Techniques*, A. Kusiak, Ed. New York: Wiley, 1993, p. 117.
- [21] S. Finger and J. R. Dixon, "A review of research in mechanical engineering design. Part II: Representations, analysis, and design for the life cycle," *Res. Eng. Design*, vol. 1, no. 2, pp. 121–137, 1989.
- [22] J. J. Shah, "Conceptual development of form features and feature models," *Res. Eng. Design*, vol. 2, no. 2, pp. 93–108, 1991.
- [23] R. Sanchez, "Strategic flexibility, firm organization, and managerial work in dynamic markets: A strategic options perspective," *Adv. Strat. Manage.*, vol. 9, pp. 251–291, 1993.
- [24] J. J. Shah and M. Mantyla, *Parametric and Feature-Based CAD/CAM*. New York: Wiley, 1995, pp. 231–248.



Chun-Che Huang received the Ph.D. degree in industrial engineering from the University of Iowa, Iowa City, and the M.S. degree in operations research from Columbia University, New York, NY.

He is an Assistant Professor in the Department of Information Engineering, National Chi Nan University, Taiwan, R.O.C. He is interested in concurrent engineering, modularity of products and systems, and scheduling.



Andrew Kusiak (M'90) is a Professor in the Department of Industrial Engineering, University of Iowa, Iowa City. He is interested in engineering design, manufacturing, healthcare systems, medical technology, and applications of artificial intelligence and optimization. He has authored and edited numerous books, and published research papers in journals sponsored by various societies. He serves on the editorial boards of a number of journals, edits book series, and is the Editor-in-Chief of *The Journal of Intelligent Manufacturing*.