

Techno-Economic Analysis of Hybrid Layered Manufacturing

K.P. Karunakaran¹, Vishal Pushpa¹, Sreenath Babu Akula¹,
Rajeev Dwivedi² and R. Kovacevic²

¹Department of Mechanical Engineering, Indian Institute of Technology Bombay, India

²Research Center for Advanced Manufacturing, Southern Methodist University, USA

ABSTRACT

Subtractive manufacturing (CNC machining) has high quality of geometric and material properties but is slow, costly and infeasible in some cases; additive manufacturing (RP) is just the opposite. Total automation and hence speed is achieved in RP by compromising on quality. Hybrid Layered Manufacturing (HLM) developed at IIT Bombay combines the best features of both these approaches. It uses arc welding for building near-net shapes which are finish machined to final dimensions. High speed of HLM surpasses all other processes for tool making by eliminating NC programming and rough machining. The techno-economic viability of HLM process has been proved through a real life case study. Time and cost of tool making using HLM promises to be substantially lower than that of CNC machining and other RP methods. Interestingly, the material cost in HLM was also found to be lower. HLM is a cheaper retrofitment to any 3 or 5 axis CNC milling machine or machining center.

Keywords: Rapid Prototyping, Arc Welding, CNC machining.

1. Introduction

CNC machining, a *subtractive* manufacturing method, is the most accurate process capable of producing objects out of any material. However, it requires human intervention for producing the cutter path and it is difficult or not possible to realize certain features through machining. Furthermore, a variety of tools are required and a large portion of the raw material goes waste as chips in CNC machining. The difficulty in developing foolproof CAPP systems for subtractive manufacturing led to the development of *additive* or *generative* manufacturing methods popularly known as *Rapid prototyping (RP)*. These processes are based on a *divide and conquer* strategy called *slicing*. The virtual object is split into thin slices that are physically realized, stacked and joined together. Therefore, these processes are also known as *Layered Manufacturing (LM)*, more appropriately so. Essentially RP is a CNC machine with an embedded CAPP system for generative manufacturing. Compression of product development cycle, feasibility of small lot production and better quality of design through more design iterations are the significant benefits of RP. RP has revolutionized the way products are designed and manufactured today [1].

The success in the CAPP system, and hence the total automation, is attained in RP by compromising on quality. Rapid prototypes are inferior in surface finish and material variety and homogeneity to machined parts. Most popular RP systems produce only nonmetallic objects.

Selective Laser Sintering (SLS), 3D Printing (3DP), Shape Deposition Manufacturing (SDM) and Laser Engineered Net Shaping (LENS) are some of the popular processes that can make metallic parts, prototypes and tools with different levels of success [2-4].

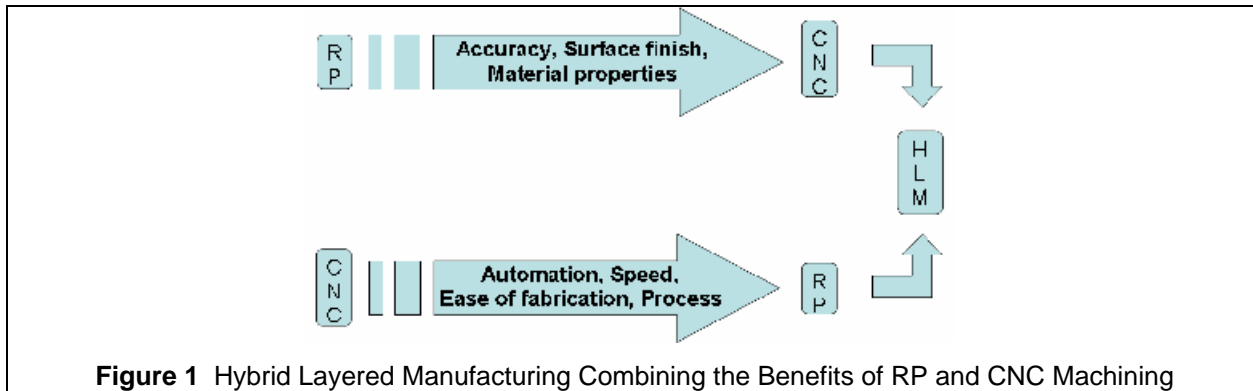

Subtractive processes can produce good quality parts but are slow; although the material removal by itself is fast, human efforts required for cutter path generation is the bottleneck. On the other hand, additive processes are fast but produce poor quality parts. Therefore, hybrid processes that judiciously combine both these approaches while carefully filtering their limitations are the need of the day (Figure 1). Such a hybrid system shall not be a compromise between CNC and RP but a combination thereof. Interestingly, the hybrid approach existed in RP from the very beginning; popular RP machines such as *Solid Ground Curing (SGC)* and *Sander's ModelMaker II* employed milling to maintain accuracy along Z axis [5]. SDM is also a hybrid process which employs a very advanced form of slicing too [6]. A hybrid RP process developed at IIT Bombay for making metallic dies and molds is called *Hybrid Layered Manufacturing (HLM)*. After a brief introduction to HLM, its techno-economic viability is demonstrated in this paper.

2. Hybrid Layered Manufacturing

Welding can be used to produce near-net shapes fast by depositing metal in layers. This near-net shape can be machined fast to obtain the desired geometric quality. Research groups at Nottingham University, Stanford University, Southern Methodist University, Fraunhofer Institute of Production Technology, Aachen, Korea Institute of Science and Technology, Indian Institute of Technology Bombay etc. are developing metallic RP processes using this principle [3, 7-11]. They are at different levels of success and some are more focused on specific applications. Some of them make use of laser welding and some prefer arc welding. Electron beam welding also has been used for deposition. While the researchers using arc welding prefer the raw material is in wire form, the laser-based processes favor powder form. *Gas Metal Arc Welding (GMAW)*, *Gas Tungsten Arc Welding (GTAW)* and *Plasma Arc Welding (PAW)* are the popular arc welding processes used for this application.

Selective sintering of powder bed and selective deposition of powder(s) are the two approaches used for metallic prototyping. Inherent support mechanism and high building speed are the advantages of powder bed technology but it does not readily lend itself to functionally gradient deposition. Many researchers are attracted towards powder deposition technology in

spite of the enormous wastage of powder (hardly 15 to 20% melts), low speed and the difficulties in powder feeding and control mainly because of better quality of deposition and feasibility of functionally gradient deposition with multiple powders [12].

HLM is a low cost retrofitment to any existing 3/ 5 axis CNC machine/ machining center for making metallic dies and molds. Therefore, arc welding was preferred to laser welding for HLM. Although GTAW is virtually spatter free, GMAW is chosen because of its simplicity; since finish machining is done, some amount of spatter is acceptable in HLM. Arc welding is a mature technology today and hence no fundamental research in welding per se is envisaged, at least in the beginning [13, 14]. *Pulsed GMAW* permits stable spray transfer at low mean current. Welding is a process with several interacting parameters; hence, any change in the desired output such as layer thickness requires control of more than one parameter. This difficulty is overcome by *synergic control* which permits adjustment of any desired welding parameter; it has a database of interactions using which it regulates the related parameters online to provide the desired outcome. This is known as “one-knob control”. Therefore, a *pulsed synergic GMAW* equipment was chosen for HLM.

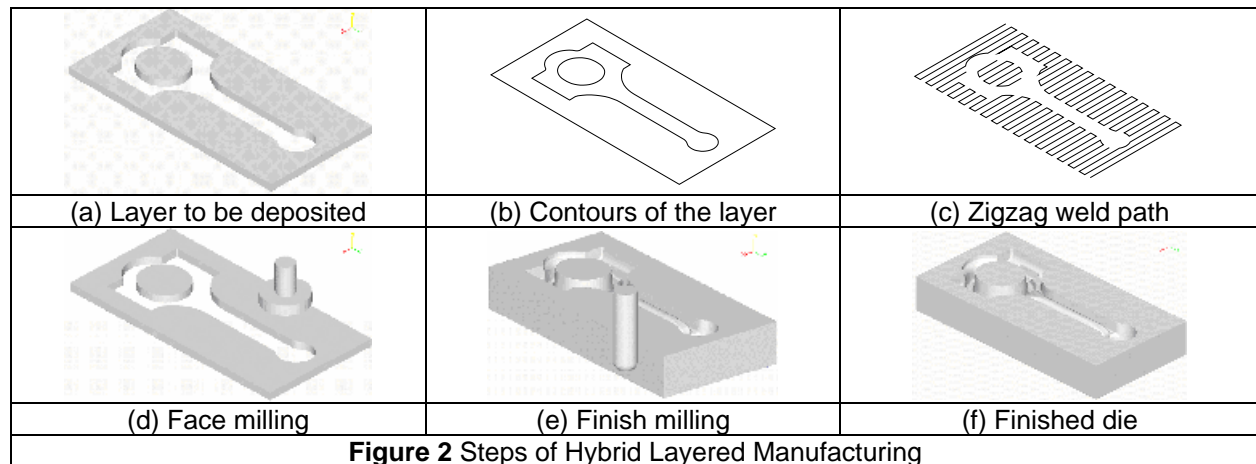

Deposition is done on a substrate which will become the base plate of the die later. Each layer which is offset by the required machining allowance of 1.0 mm to 1.5 mm is built in uniform slices. One such slice and its contours are shown in Figure 2a & b. Deposition was earlier done using a *direction-parallel* (or *zigzag* or *raster*) fill pattern followed by contouring (Figure 2c). The raster directions of the consecutive layers were orthogonal to get better material homogeneity. However, *contour-parallel* fill pattern is found to be better. After deposition, every layer is face milled. Face milling ensures Z accuracy and provides a scallop-free nascent surface for next deposition (Figure 2d). This results in the near-net shape of the tool. *Stress relieving* was not needed for mild steel wire. However, this may be essential for harder materials.

As even the most complex tool geometry will have complete ‘visibility’ to the cutter, it can be machined using a 3-axis CNC machine with ball, bull and flat end mills. As the near-net shape has only a small machining allowance, there is no need for roughing cuts and it can be finished directly (Figure 2e). While deposition proceeds bottom-up, the machining happens in a top-down manner but in adaptive slices so as to maintain the surface finish within the specified

scallop height. HLMSoft works fine presently for a single ball end mill. The code for an optimal cutter path with a combination of ball, bull and flat end mills is under development.

A 3-axis CNC milling machine of a tool room was retrofitted with HLM. Figure 3a shows the HLM setup. It did not have spare relays that can be used for (i) lowering and raising the welding torch and (ii) switching on/off of welding. Therefore, the coolant system was disconnected and the corresponding relay activated by the NC commands M08/M09 was used for the interfacing. Since only one relay was available, it was decided to latch on/off of welding with lowering/raising of the torch. This was accomplished using a limit switch which is hit at the end of the downward stroke of the pneumatic cylinder as shown in Figure 3b. The substrate is to be mounted on a water cooled fixture (Figure 3c).

3. Experimental Investigations

Unlike a joining process where emphasis is on weld penetration and rate of deposition, HLM emphasizes on process stability, less and uniform heat input (for minimum distortion and better microstructure), sharp feature definition, minimum machining and high hardness of the die or mold. HLM is influenced by several parameters that pertain to GMAW and welding and milling paths. In order to understand their interdependencies and optimize the HLM process accordingly, a series of experiments were carried out. To meet the requirements of HLM, the parameters that change less frequently were kept constant to the following values after some preliminary experiments:

Gas mixture	: 82% Ar + 18% CO ₂	Welding wire	: ER70S-6 CCMS
Torch speed v_t	: 1,000 mm/min	Wire Diameter d_w	: 0.8 mm
Nozzle gap	: 12 mm	Machining allowance	: 1.0 mm

Subsequent experiments were for understanding the interdependencies of the parameters and identify the most influencing ones for HLM. As pulsed synergic GMAW is used, *mean current* I_m and *step over increment* d_s are the only parameters that influence HLM process. These two parameters influence the *layer thickness* t and the *yield* y of the process. Note that t here refers to the maximum layer thickness possible for the prevailing conditions so as to have a scallop-free layer. The actual layer built by the user shall be shorter than this value. We define yield as the ratio of the volume of the layer after face milling to the volume of the metal deposited. During each layer building, some amount of metal is lost through face milling and a very small amount in spatter. Since the spatter loss is very less under stable conditions, it is ignored. Yield reflects the material utilization of the process, very similar to casting.

$$y = \frac{at}{\frac{\pi}{4} d_w^2 v_w \left(\frac{l}{v_t} \right)} \times 100 \% = \frac{400 at v_t}{\pi d_w^2 v_w l} \%$$

where a is the area of the layer, l is the total length of the path, v_w wire feed speed and d_w is the wire diameter. A series of experiments were performed to generate the database that reflects the influence of I_m and d_s on t and y . From this database, the user can choose the mean current to obtain the required layer thickness. Furthermore, he can also slightly adjust the layer thickness so as to maximize yield.



(a) Overall view of the setup

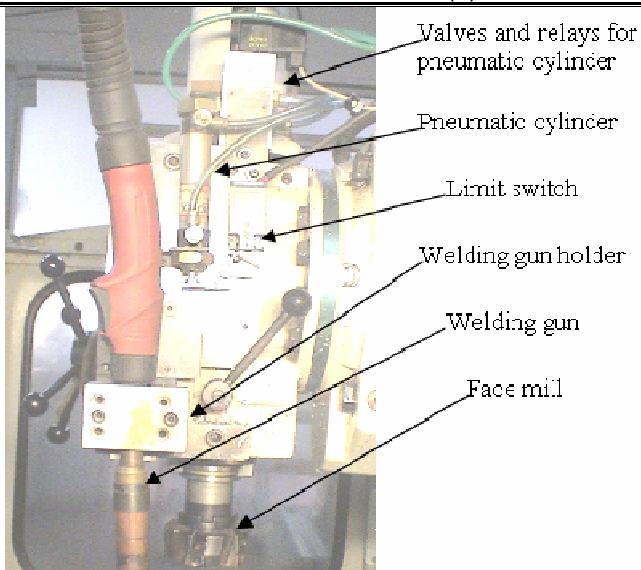

(b) Torch mounted on the spindle head

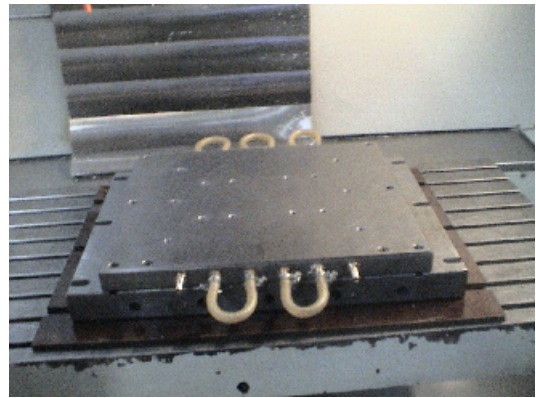

(c) Water cooled fixture

Figure 3 Hybrid Layered Manufacturing Machine at Indo German Tool Room, Aurangabad

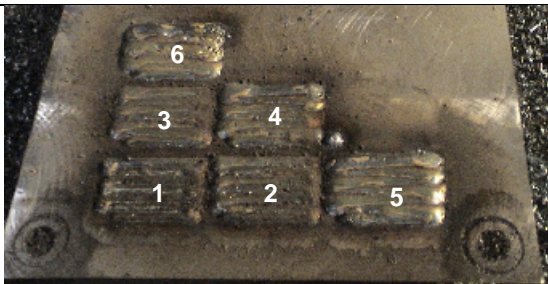

(a) Before face milling

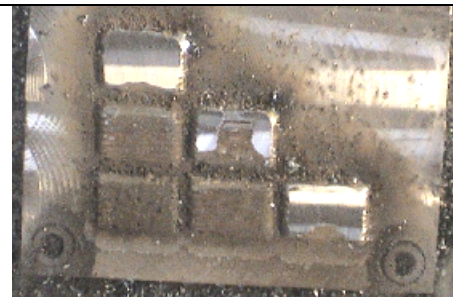

(b) After one pattern completely became flat

Figure 4 Layer Thickness Measurement for Different Conditions

Controlled deposition occurs when the mean current is in the range of [30A, 90A]. The feasible range chosen for step over increment was [1 mm, 4 mm]. Since only two parameters

were involved, full factorial design of experiments was adopted [15]. A rectangular layer of 30mm x 20mm was deposited for different combinations of I_m and d_s (Figure 4). NC programs were written - one for each step over increment - for depositing nine of these patterns. After deposition, face milling was done at different Z levels in steps of 0.1mm till the scalloped surface became completely flat. Six rectangular patterns deposited for a certain trial is shown in Figure 4a. The numbers marked on each indicate the order in which the deposition took place. Before the torch moved from one pattern to the other, mean current was adjusted. Figure 4b shows these patterns after face milling when the 6th pattern (top left) just became flat. t and y corresponding to each combination of I_m and d_s after face milling it flat was recorded in Table 1. From these values, graphs shown in Figure 5 were constructed.

Table 1 Response Table for Selection of Layer Thickness

$d_w = 0.8 \text{ mm}$				$v_t = 1,000 \text{ mm/min}$	
$d_s \text{ (mm)}$	$L \text{ (mm)}$	$I_m \text{ (A)}$	$v_w \text{ (mm/min)}$	$t \text{ (mm)}$	Yield (%)
1.0	650	30	4.4	1.0	41.74
1.0	650	40	6.2	2.0	59.24
1.0	650	50	7.8	2.8	65.93
1.0	650	60	9.6	3.5	66.95
1.0	650	70	11.4	4.3	68.07
1.0	650	80	13.2	5.0	69.56
1.5	440	30	4.4	0.6	36.99
1.5	440	40	6.2	1.2	52.50
1.5	440	50	7.8	1.8	62.60
1.5	440	60	9.6	2.3	65.00
1.5	440	70	11.4	2.8	65.48
1.5	440	80	13.2	3.4	69.88
2.0	350	30	4.4	0.5	38.76
2.0	350	40	6.2	1.1	55.01
2.0	350	50	7.8	1.6	69.96
2.0	350	60	9.6	2.1	74.60
2.0	350	70	11.4	2.6	76.44
2.0	350	80	13.2	3.0	77.50
2.5	290	30	4.4	0.3	28.06
2.5	290	40	6.2	0.9	59.75
2.5	290	50	7.8	1.4	73.88
2.5	290	60	9.6	1.8	77.17
2.5	290	70	11.4	2.2	78.06
2.5	290	80	13.2	2.6	81.07
2.5	290	90	15.2	2.9	78.53
3.0	260	30	4.4	0.0	0.00
3.0	260	40	6.2	0.2	14.80
3.0	260	50	7.8	0.8	47.09
3.0	260	60	9.6	1.2	57.39
3.0	260	70	11.4	1.5	59.37
3.0	260	80	13.2	1.8	62.60
3.0	260	90	15.2	2.1	63.43
3.5	230	30	4.4	0.0	0.00
3.5	230	40	6.2	0.0	0.00
3.5	230	50	7.8	0.4	26.26
3.5	230	60	9.6	0.7	37.84
3.5	230	70	11.4	1.1	49.21
3.5	230	80	13.2	1.4	55.04

3.5	230	90	15.2	0.9	30.73
4.0	200	30	4.4	0.0	0.00
4.0	200	40	6.2	0.0	0.00
4.0	200	50	7.8	0.0	0.00
4.0	200	60	9.6	0.3	18.65
4.0	200	70	11.4	0.8	41.16
4.0	200	80	13.2	1.1	49.74
4.0	200	90	15.2	1.4	54.97

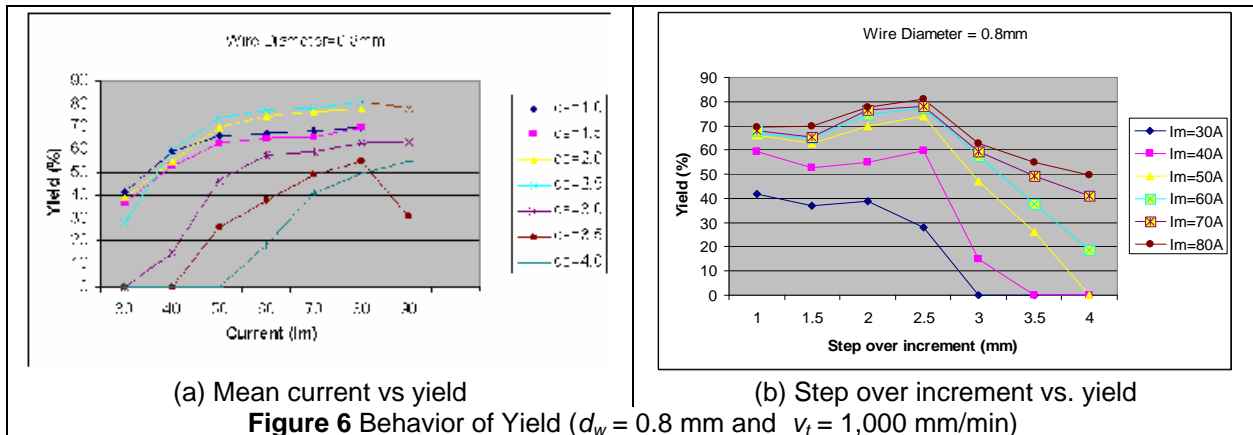
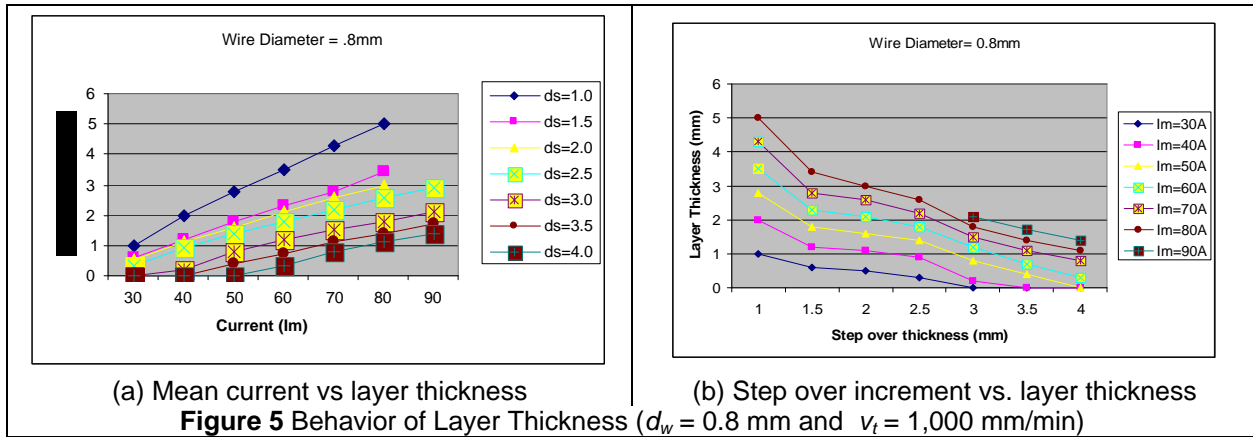

From Figure 5a, it is clear that the layer thickness steadily increases with the mean current, almost linearly. As the step over increment increases, the layer thickness attained decreases nonlinearly; initially the rate of decrease is more (Figure 5b). Furthermore, the plots of mean current vs layer thickness for different step over increments are not parallel – they diverge; this shows the presence of interaction between mean current and step over increment. This interaction is later analyzed using ANOVA [16].

From Figure 6a, it is clear that yield rapidly increases with the mean current initially and then becomes almost flat. Higher the yield less will be the wastage of material and hence more economical will be the HLM process. So, it is advisable to choose the current in the flat region. As the step over increment increases, yield increases in the beginning and then decreases (Figure 6b). Therefore, there exists an optimal value of step over increment for a given current. It is desirable to operate around this optimal value. The user normally chooses the layer thickness

based on the size and geometric considerations of the object to be built. These graphs can be used to select the appropriate combination of I_m and d_s to obtain this required layer thickness. While doing so, the user can also pay attention to the yield; in other words, he has the option of slightly perturbing the chosen layer thickness in order to improve yield.

Analysis of variance

Two way ANOVA was used to determine the extent of influence of the independent parameters viz., I_m and d_s and their interaction over layer thickness and yield. From Table 2, it is obvious that the influence of step over increment on layer thickness as well as yield is more than that of mean current. The influence of interaction is present but not dominant. Therefore, any change in layer thickness is better achieved by changing d_s rather than I_m . Looking at the requirement of low heat input for less distortion, change in d_s may be preferred to I_m when layer thickness is to be increased and change in I_m may be preferred when layer thickness is to be decreased.

Since step over increment is the major factor influencing the process, it will be useful to study its effect on mean yield in context of wire diameter. The mean yield value corresponding to various step over increments are listed in Table 3 for two wire sizes viz., 1.2mm and 0.8mm. The yield vs step over increment curves shown in Figure 7 has a bell shape indicating the presence of an optimal point. Interestingly, this optimal point shifts rightward as the wire size decreases. This means that lower wire diameter will reduce wastage of material. As the optimal step over increment is higher in lower wire diameter, less time may be required. Both these reasons make lower wire diameter preferable.

Table 2 Analysis of Variance

Layer Thickness	
Factor/ Interaction	Variance
I_m	16.06
d_s	42.97
$I_m \times d_s$	4.58
Total	63.61

Yield	
Factor/ Interaction	Variance
I_m	1530.71
d_s	2720.45
$I_m \times d_s$	318.01
Total	4569.17

Table 3 Effect of Step Over Increment Yield

d_s mm	Yield y (%)	
	$d_w = 1.2$ mm	$d_w = 0.8$ mm
1.0	65.51	61.95
1.5	72.21	58.74
2.0	64.52	65.38
2.5	55.25	68.07
3.0	46.95	43.53
3.5	42.01	28.44
4.0	38.82	23.50

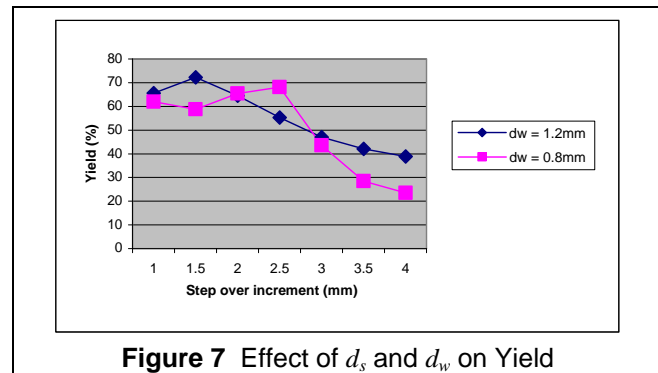
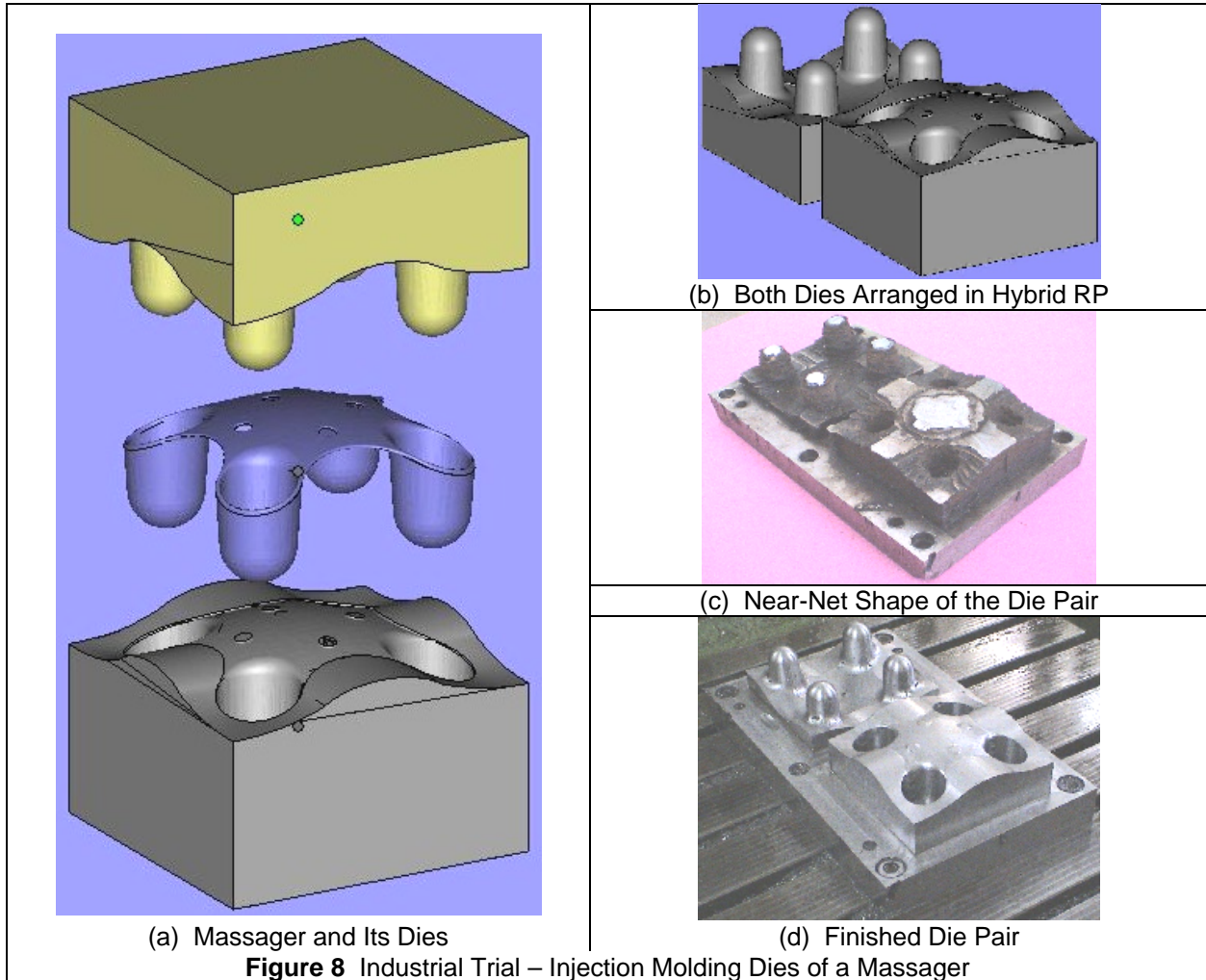

Figure 7 Effect of d_s and d_w on Yield

4. Techno-Economic Viability of HLM

Having done the experiments and generated the required database for the HLM user, an industrial trial was carried out to demonstrate its commercial viability vis-à-vis the conventional

tool making method, viz., CNC machining from a block. *Magic Massager* is a transparent part used for massaging. CAMTools, a tool room in Mumbai, had recently made the injection molds of this massager. They furnished us the cost and time for making these molds. The same molds were built using HLM aiming to arrive at a time and cost comparison of both these routes.



The material used by CAMTools was P20 with a hardness of about 26 HRC and a density of $7,800 \text{ kg/m}^3$. Each mold was built from a block of $125\text{mm} \times 125\text{mm} \times 80\text{mm}$. Each block weighed 9.75 kg, costing Rs. 3,120.00 for both dies. The first activity in CNC machining is NC programming and the equivalent activity in HLM is data processing using HLMSOft. For a valid STL file, HLMSOft can process data in about 10-15 min whereas the NC programming activity using CAM software such as Unigraphics may take several hours. The near-net shape in CNC route is obtained by rough machining the block and the same is obtained by depositing layers in HLM. The finish machining is almost same in both cases.

Figure 8a shows the cavity and punch inserts of these molds in exploded view. Both of them were small enough for building together along Y axis as shown in Figure 8b. This pair was built using HLM over a MS substrate of $275\text{mm} \times 150\text{mm} \times 30\text{mm}$. It weighed 9.66kg and it costed Rs. 47 per kg. Therefore, the cost of the substrate was Rs. 453.67. The near-net shape of these

molds is shown in Figure 8c and its finished version is in Figure 8d. Each layer was 1.5 mm thick. The total die height was about 75 mm. Since more than 30 mm at the bottom has no variation in section, the thickness of the substrate was chosen as 30 mm. The remaining height was built in 30 layers. The time taken for each layer building is presented in Table 4.

Table 4 Time Taken for Building the Near-net Shape of the Injection Molds of Magic Massager

Punch				Die			
Layer No	Time (min)			Layer No	Time (min)		
	Weld Deposition	Face Milling	Cumulative		Weld Deposition	Face Milling	Cumulative
1	8.5	2.15	10.65	1	8.5	2.15	10.65
2	8.2	2.15	21.00	2	8.7	2.15	21.50
3	7.9	2.15	31.05	3	8.3	2.15	31.95
4	6.9	2.15	40.10	4	8.0	2.15	42.40
5	6.1	2.15	48.35	5	7.4	2.15	51.75
6	5.0	2.15	55.50	6	7.2	2.15	61.10
7	4.2	2.15	61.85	7	7.1	2.15	70.35
8	3.9	2.15	67.90	8	6.9	2.15	79.40
9	3.7	2.15	83.75	9	6.9	2.15	88.45
10	3.5	2.15	79.40	10	6.9	2.15	97.50
11	2.9	2.15	94.45	11	6.9	2.15	106.55
12	1.8	2.15	88.40	12	6.9	2.15	115.60
13	1.6	2.15	92.15	13	6.9	2.15	124.65
14	1.6	2.15	95.90	14	6.9	2.15	143.70
15	1.6	2.15	99.65	15	6.9	2.15	152.75
16	1.6	2.15	103.90	16	6.9	2.15	141.80
17	1.6	2.15	107.15	17	6.9	2.15	160.85
18	1.6	2.15	110.90	18	6.9	2.15	169.90
19	1.6	2.15	114.65	19	6.9	2.15	178.95
20	1.6	2.15	118.40	20	6.9	2.15	188.00
21	1.6	2.15	122.15	21	6.9	2.15	197.05
22	1.6	2.15	125.90	22	5.2	2.15	204.40
23	1.6	2.15	129.65	23	5.0	2.15	211.55
24	1.6	2.15	133.40	24	4.6	2.15	218.30
25	1.6	2.15	137.15	25	4.3	2.15	224.75
26	1.4	2.15	140.70	26	3.7	2.15	230.60
27	1.3	2.15	144.15	27	3.5	2.15	236.25
28	1.3	2.15	147.60	28	3.7	2.15	242.10
29	1.2	2.15	150.95	29	2.5	2.15	246.75
30	0.5	2.15	153.63	30	1.5	2.15	250.40

The volume of the deposited portion of both the molds is $0.00059075461 \text{ m}^3$. Assuming an average yield of 60%, the weight of the wire consumed in building these molds is 7.68 kg. As the wire costs Rs. 68 per kg, the cost of the welding wire consumed is Rs. 522.23. Comparison of manufacturing these molds through CNC route at CAMTools and HLM route are presented in Tables 5 and 6, the former in time and the latter in cost. The following interesting inferences were made from this case study:

- HLM route for this case took 42% less time than that of the CNC route.
- HLM route for this case costed 28% less than that of the CNC route.
- Cost of the raw material was lower in HLM for this case study. However, this cannot be generalized claim in favor of HLM owing to the variations in the grades of the materials in both cases.
- Life of HLM molds built from MS wire will be only very marginally less than that of CNC machined molds as the difference in their hardness values is not substantial (just 4 HRC).

Table 5 Comparison of manufacturing Time of Magic Messager die Using HLM and CNC Machining

CNC		HLM	
Processing Step	Time (min)	Processing Step	Time (min)
NC program generation	480.00	Data processing	15.00
Rough machining	960.00	Near-net shape manufacture	404.03
Finish machining	1,020.00	Finish machining	1,020.00
Total	2,460.00	Total	1,439.03

<p>NC programming 20% Rough Machining 39% Finish Machining 41%</p>	<p>Data Processing 1% Near-Net Shape Manufacture 28% Finish Machining 71%</p>
--	---

Table 6 Comparison of manufacturing Cost of Magic Messager die Using HLM and CNC Machining

CNC		HLM	
Description	Cost (Rs.)	Description	Cost (Rs.)
Material cost (solid block of tool steel)	3,120.00	Material cost (MS substrate @ Rs. 47 per kg and CCMS welding wire @ Rs. 68 per kg)	975.90
NC programming cost using a CAM package @ Rs. 400 per hour	3,200.00	Data processing cost using HLMSOFT @ Rs. 400 per hour	100.00
Machine hour cost of BSF 3 axis milling machining centre @ Rs. 650 per hour (during roughing and finishing)	21,450.00	Machine hour cost of WF52D Mikron 3 axis milling machine integrated with Fronius TPS4000 welding machine @ Rs. 800 per hour (during deposition, face milling and finishing)	18,987.07
Total	27,770.00	Total	20,062.97

<p>Material Cost 1% Programming Cost 12% Machining Cost 77%</p>	<p>Material Cost 5% Data Processing Cost 0.5% Machining Cost 34.5%</p>
---	--

5. Conclusion

Hybrid Layered Manufacturing presented in this paper is a low cost retrofitment to any existing 3/ 5 axis CNC machine/ machining center for making metallic dies and molds. It combines the

best features of two well known and cheaper processes, viz., arc welding and milling. Eliminations of rough-machining as well as manual NC programming are the two reasons for its high speed. Through a case study, it was proved that HLM is significantly cheaper and faster than CNC machining. We are presently focusing on better heat management (i) through a table maintained at a constant preheat and (ii) segmenting and distributing the weld paths to minimize temperature gradients. Thinner filler wire gives less distortion and better resolution. Use of multiple wires will enhance the speed of deposition and lends itself for depositing functionally graded matrix. Therefore, development of a welding torch that can handle an array of fine filler wires is the future goal of HLM. Arc welding as well as laser based processes produce only near-net shapes and hence machining is unavoidable. The cost and speed of deposition using arc welding are superior to laser welding by orders of magnitude. However, it has not received adequate attention it deserves from the research community.

References

1. Karunakaran K.P. and Bapat V.P. (2001): "Rapid Product Development: Synergic Integration of Time Compression Technologies", *Proceedings of Workshop on Rapid Product Development*, IIT Bombay, June 7-8.
2. Pham, D.T., Dimov, S. and Lacan, F. (1999): "Selective Laser Sintering: Applications and Technological Capabilities", *Proceedings of the Institution of Mechanical Engineers*, Vol.213, Part B, pp. 435 – 449.
3. Merz, R. Prinz, F.B., Ramaswami, K., Terk, M and Weiss, L.E. (1994): "Shape Deposition Manufacturing", *Proceedings of Solid Freeform Symposium*, Austin, pp. 1 – 8.
4. <http://www.optomec.com/html/lens.htm> (2005): "Laser Engineered Net Shaping Technology", Web site of OptoMec.
5. Chua Chee Kai and Leong Kah Fai (1997): *Rapid Prototyping: Principles and Applications in Manufacturing*, John Wiley & Sons.
6. Krishnan Ramaswamy, (1997): "Process Planning for Shape Deposition Manufacturing", Ph.D. Dissertation, Department of Mechanical Engineering, Stanford University.
7. Spencer, J.D., Dickens, P.M. and Wykens, C.M. (1998): "Rapid Prototyping of Metal Parts by 3D Welding", *Proc. Instn Mech Engrs* Vol. 212, PartB, pp. 175-182.
8. Wang, H., Jiang, W., Ouyang, J., and Kovacevic, R. (2004): "Rapid Prototyping of Parts of 4043 Al-Alloy by VP-GTAW", *Journal of Materials Processing Technology*, Vol. 148, No. 1, pp. 93-102.
9. Fritz Klocke, H. Wirtz and W. Meiners (1996): "Direct Manufacturing of Metal Prototypes and Prototype Tools", *Solid Freeform Fabrication Proceedings*, Austin, pp. 141-148
10. Song, Y.A., Park, A., Choi, D. and Jee, H. (2005): "3D Welding and Milling: Part I - A Direct Approach for Freeform Fabrication of Metallic Prototypes", *Machine Tools & Manufacture*, Vol. XX, pp. 1-6 (to appear).
11. Karunakaran, K.P., Vivekananda S.P., Jadhav, S.J., Bhadauria, P. and Pandey, A. (2000): "Rapid Prototyping of Metallic Parts and Moulds", *Journal of Materials Processing Technology*, Vol. 105, pp. 371-381.
12. Todd Grimm (2004): "Direct Metal on the Rise", *SME Manufacturing Engineering*, October, pp 83-91.
13. Cary Howard B. (1989): "Modern welding Technology", *Englewood Cliffs: Prentice-hall*.
14. Parmar R. S. (1997): "Welding Processes and Technology", *Khanna Publishers*.
15. Lochner Robert H., Matar Joseph E. (1990): "Designing for Quality", Chapman and Hall.
16. Ross, P.J. (1988): "Taguchi Techniques for Quality Engineering", *McGraw-Hill*.

This document was created with Win2PDF available at <http://www.daneprairie.com>.
The unregistered version of Win2PDF is for evaluation or non-commercial use only.